



**NorDig Rules of Operation**  
for  
**NorDig Unified Receiver Networks**  
**Version 3.1.2**

Date: 13.04.2021

1	Introduction .....	5
1.1	Scope .....	5
	Document History .....	5
1.2	Terminology .....	5
1.3	Definitions .....	6
1.4	References .....	6
1.5	List of Abbreviations .....	14
2	NorDig Broadcaster distributions network.....	16
2.1	Introduction .....	16
2.2	Broadcast distribution systems (informative).....	16
2.3	Implementation and management.....	19
3	The modulators and tuners of NorDig broadcast .....	21
3.1	Common Features.....	21
3.2	Satellite Modulation, Coding and Framing .....	21
3.3	Cable Tuner and Demodulator .....	23
3.4	Terrestrial Tuner and Demodulator .....	26
3.5	IP-based Front-End.....	40
4	MPEG-2 Multiplexing.....	42
4.1	General Multiplexing .....	42
4.2	DVB scrambling.....	43
4.3	System Time Clock/Program Referencs (PCR) .....	44
5	Video .....	45
5.1	General requirements .....	45
5.2	Supported resolutions .....	46
5.3	Supported frame rates.....	47
5.4	Video resolution scaling Up-sampling / Up-converting.....	47
5.5	Colorimetry .....	48
5.6	Dynamic changes in the video stream .....	49
5.7	MPEG-2 Minimum video bandwidth.....	50
5.8	Frame Cropping.....	50
5.9	Overscan.....	50
5.10	Video Output and Display .....	50
5.11	Restrictions on analogue video output .....	51
5.12	Display of 4:3 aspect ratio content .....	51
5.13	Rescaling for HbbTV application.....	51
5.14	Graphic compositing with HDR video - informative .....	51
6	Audio.....	52
6.1	General .....	52
6.2	Supplementary Audio Services .....	56
6.3	Audio Encoding.....	58
6.4	Multiplexing audio into MPEG-2 TS and Signalling.....	67
6.5	Audio Prioritisation within the NorDig IRD (informative).....	74
7	Teletext and Subtitling .....	78
7.1	General .....	78
7.2	EBU Teletext.....	80
7.3	DVB Subtitling-System.....	80
7.4	TTML Subtitling-System .....	81
8	Interfaces and Signal Levels.....	82
9	Conditional Access.....	83
9.1	General .....	83
9.2	Use of the Common Interface.....	83

9.3	Use of Smart Card Reader (IRD and CA Module).....	84
10	System Software Update (SSU) .....	85
10.1	System software .....	85
10.2	SSU functionality .....	87
10.3	System Software Update via local interface or IP-based interface (Internet) .....	87
10.4	Network Management and Provisioning for IP-based IRDs (IPTV) .....	88
10.5	System Software Update via broadcast channels .....	88
11	Performance .....	93
12	Service Information.....	94
12.1	General .....	94
12.2	Network Information Table (NIT).....	100
12.3	Services Description Table (SDT).....	112
12.4	Event Information Table .....	115
12.5	Time and Date Table and Time Offset Table .....	123
12.6	Conditional Access and Program Map Tables .....	124
12.7	SSU UNT Descriptors .....	135
12.8	Related Content Table (NorDig PVR only) .....	135
12.9	NorDig Broadcast Record List syntax (NorDig PVR only) .....	135
13	Navigator.....	136
14	NorDig PVR.....	137
14.1	General .....	137
14.2	Implementation overview.....	137
15	IRD System Software and API.....	139
15.1	NorDig Basic IRD.....	139
15.2	API – HbbTV .....	139
16	User Preferences.....	142
Annex A : NorDig Members and Partners .....		143
1	NorDig Full Members .....	143
2	NorDig Associated Members .....	143
3	Partners.....	143
Annex B : NorDig PVR.....		145
1	CRID Types .....	145
1.1	Programme CRID .....	145
1.2	Series CRID .....	145
1.2	Recommendation CRID .....	145
2	Use of the Instance Metadata Identifier .....	146
3	CID Carriage.....	146
4	CRID Encoding.....	146
5	Default Authority Descriptor .....	147
6	Optional Trailer booking/Promotional Linking .....	147
7	Series recording or Series link .....	147
8	Complete recording.....	147
9	Optional Trailer booking/Promotional Linking .....	147
10	Series recording or Series link .....	148
11	Split recording.....	148
12	Safe margins.....	149
13	Presentation and management of scheduled recordings.....	150
14	Presentation and management of acquired recordings.....	150
15	Cache in background.....	150
Annex C : AC-4 Audio (informative) .....		151
Annex D : Old text from RoO ver. 2.5 – chapter 3 The modulators and tuners of NorDig Broadcaster		156
3.5	Tuning and Navigation.....	156
3.6	DVB specific identifiers.....	156



3.7	Specific tuning for Satellite Networks .....	163
3.8	Specific tuning for cable networks.....	167
3.9	Specific tuning for Terrestrial Networks.....	171

# 1 Introduction

## 1.1 Scope

In the context of this document,

- A NorDig Broadcaster is a provider of Audio, Video and Services for public consumption, transmitting such content via Broadcast RF or via IP.
- An IRD (Integrated Receiver Decoder) is a broadcast receiver and decoder device for home / domestic usage. An IRD may be an Integrated Digital TV set or a Set Top Box.
- A Nordig IRD is an IRD compliant to
  - o Nordig Unified 3.1.2 [106]
  - o Nordig Test 3.1.2 [62]

The NorDig Rules of Operation (RoO) provides requirements on the configuration of transmission parameters, including the related standards, to design transmissions of content interoperable with NorDig IRD.

The Rules of Operation may also be used as a guideline by IRD manufacturers to understand how NorDig Broadcasters construct compliant transmissions.

### **Document History**

Version	Date	Comments
0.9	2002-05-30	This is the first approved version pf the NorDig Rules of Operation for NorDig I and II Receiver Networks
1.0	2004-10-28	Updated to reference to NorDig Unified v 1.0.2
2.5	2016-07-21	Rewritten and updated to reference to NorDig Unified v. 2.5.1
3.1.1	2020-11-20	Updated to be in line with NorDig Unified v. 3.1.1. This update is a complete update of the RoO specification. The RoO specification is also redesigned corresponding with the IRD Unified specification design layout and chapter numbering. Note: messing references in the reference list will be updated in next version when NorDig Unified specification is updated.
3.1.2	2021-04-13	This version includes updated of ch.2 NorDig Broadcast distribution network, ch.3.1.2 FE Terrestrial, ch.10 SSU and ch. 15.2 HbbTV.

## 1.2 Terminology

<b>Shall</b> (Mandatory)	This word means that the item is mandatory
Should (Recommended)	This word means that this item is not mandatory but is recommended.
May (Optional)	This word means that this item is optional and is not required to be supported

### 1.3 **Definitions**

<b>Broadcaster</b>	Provider of Audio, Video and Services for public consumption, transmitting such content via Broadcast RF or via IP following the NorDig requirements.
<b>NorDig Transmission</b>	Transmission compliant to this NorDig Rules of Operation.
<b>NorDig Broadcaster network</b>	The medium for transmission, and reach of the NorDig Broadcaster
<b>Operator/Distributor</b>	Operator providing the TV distribution network (satellite, cable, terrestrial, IP network) which distributes the TV services signals to the viewers. The TV distribution network can consist of both unscrambled (e.g. “Free-to-air”) and scrambled (e.g. “Pay TV”, “Free-Scrambled”) TV services.
<b>Pay TV Operator</b>	Operator having the commercial agreement with the viewers for CA/Pay TV services and normally having agreement with the Broadcaster for their Pay TV services. The Operator normally provides and/or specifies the means for the viewers to consume scrambled/Pay TV services (e.g. smartcards, CA Modules, STBs etc).
<b>IRD</b>	Integrated Receiver Decoder. Broadcast receiver and decoder device for home / domestic usage. An IRD may be an Integrated Digital TV (iDTV) set or a Set Top Box (STB).
<b>NorDig IRD</b>	IRD compliant to NorDig Unified 3.1.1 [106], and successfully tested according to NorDig Test 3.1.1 [107]
<b>Legacy NorDig IRD</b>	IRD compliant to a version of NorDig specification older/lower than NorDig Unified 3.1.1 [106] i.e. may not be fully compliant with the latest specification.
<b>CA Vendor</b>	The provider of the Conditional Access system to the NorDig Broadcaster or the NorDig Operator
<b>Content Owner</b>	The provider of Video and or Audio assets to be broadcast, e.g. the Hollywood Studios

### 1.4 **References**

[1] Void	Void
[2] Void	Void
[3] DVB CSA	For signalling, refer to ETSI TS 100 289, Digital Video Broadcasting (DVB); Support for use of the DVB Scrambling Algorithm version 3 within digital broadcasting systems.  For the DVB Common Scrambling Algorithm (CSA) version 2 (DVB-CSA2) or version 3 (DVB-CSA3), contact the custodian SISVEL for more information:  <a href="https://www.sisvel.com/licensing-programs/digital-video-display-technology/dvb-csa/introduction">https://www.sisvel.com/licensing-programs/digital-video-display-technology/dvb-csa/introduction</a>  <a href="https://www.etsi.org/security-algorithms-and-codes/dvb-csa-licences">https://www.etsi.org/security-algorithms-and-codes/dvb-csa-licences</a>
[4] EN 50049-1	Domestic and similar electronic equipment interconnection requirements: Peritelevision Connector.

[5] EN 60728-1 and 50083-9	<p>Cenelec EN 60728-1, Cable networks for television signals, sound signals and interactive services - Part 1: System performance of forward paths.</p> <p>Cenelec EN 50083-9, Cabled distribution systems for television, sound and interactive multimedia signals – Part 9: Interfaces for CATV/SMATV headends and similar professional equipment for DVB/MPEG-2 transport streams.</p>
[6] EN 50157-2-1	Domestic and similar equipment interconnection requirements: AVlink-Part 2-1: Signal quality matching and automatic selection of source devices.
[7] EN 50221	Common Interface specification for Conditional Access and other Digital Video Broadcasting Decoder Applications.
[8] EN 50494	Satellite signal distribution over a single coaxial cable in single dwelling installations.
[9] EN 55013	Limits and methods of measurements of radio disturbance characteristics of broadcast receive equipment and associated equipment.
[10] EN 61319-1	Interconnections of satellite receiving equipment – Part 1: Europe.
[11] ETSI EN 300 421 v1.1.2	Digital Video Broadcasting (DVB): Digital broadcasting systems for television, sound and data services: Framing structure, channel coding and modulation for 11/12 GHz Satellite services. (DVB-S).
[12] ETSI EN 300 429 v1.2.1	Digital Video Broadcasting (DVB): Digital Broadcasting Systems for Television, Sound and Data Services; Framing Structure, Channel Coding and Modulation for Cable Systems (DVB-C).
[13] ETSI EN 300 468 v1.16.1	Digital Video Broadcasting (DVB): Specification for Service Information (SI) in (DVB) systems.
[14] ETSI EN 300 472 v1.4.1	Digital Video Broadcasting (DVB): Digital Broadcasting Systems for Television, Sound and Data Services; Specification for Conveying ITU-R System B Teletext in Digital Video Broadcasting (DVB) Bitstreams.
[15] ETSI EN 300 473 v1.1.2	Digital Satellite Master Antenna Television Distribution System (SMATV).
[16] ETSI EN 300 706 V1.2.1	Digital Video Broadcasting (DVB): Enhanced Teletext specification.
[17] ETSI EN 300 743 v1.3.1	Digital Video Broadcasting (DVB): DVB Subtitling Systems.
[18] ETSI EN 300 744 v1.6.1	<p>Digital Video Broadcasting (DVB); DVB Framing structure, channel coding and modulation for digital terrestrial television (DVB-T).</p> <p><a href="https://www.etsi.org/deliver/etsi_en/300700_300799/300744">https://www.etsi.org/deliver/etsi_en/300700_300799/300744</a></p>

[19] ETSI EN 302 755 v1.2.1	Frame structure channel coding and modulation for a second-generation digital terrestrial television broadcasting system (DVB-T2). <a href="https://www.etsi.org/deliver/etsi_en/302700_302799/302755/">https://www.etsi.org/deliver/etsi_en/302700_302799/302755/</a>
[20] ETSI EN 302 307 v1.2.1	Digital Video Broadcasting (DVB): Second generation framing structure, channel coding and modulation systems for Broadcasting, Interactive Services, News Gathering and other broadband satellite applications (2009-08) (DVB-S2).
[21] ETSI ETR 162	Digital Video Broadcasting (DVB); Allocation of Service Information (SI) codes for DVB systems.
[22] ETSI ETR 289	Digital Video Broadcasting (DVB); Support for use of scrambling and Conditional Access within digital broadcasting systems.
[23] HbbTV Test Suite	HbbTV Test Suite (see details of version in NorDig Test Plan related to HbbTV).
[24] ETSI TR 101 202 V1.2.1	Digital Video Broadcasting (DVB); Implementation guidelines for Data Broadcasting.
[25] ETSI TS 101 211 V1.12.1	Digital Video Broadcasting (DVB); Guidelines on the Implementation and Usage of DVB Service Information (SI).
[26] ETSI TS 101 154 V2.6.1	Digital Video Broadcasting (DVB); Specification for the use of Video and Audio Coding in Broadcast and Broadband Applications.
[27] ETSI ES 102 796 V1.6.1	Hybrid Broadcast Broadband TV (HbbTV), (referring to HbbTV version 2.0.3 functionality).
[28] ETSI TS 102 006 V1.4.1	Digital Video Broadcasting (DVB); Specification for System Software Update (SSU) in DVB Systems.
[29] ETSI TS 102 034 V1.4.1	Digital Video Broadcasting (DVB); Transport of MPEG-2 Based DVB Services over IP based Networks.
[30] ETSI TS 102 114 V1.4.1	ETSI Technical Specification (TS): DTS coherent acoustics; Core and Extensions with Additional Profiles.
[31] Void	Void
[32] ETSI TS 102 323 V1.4.1	Digital Video Broadcasting (DVB); Carriage and signalling of TV-Anytime information in DVB transport streams, 2010-01.
[33] ETSI TS 102 366 V.1. 4.1	ETSI Technical Specification (TS): Digital Audio Compression (AC-3, Enhanced AC-3) September 2018.
[34] ETSI TS 102 822-4 V1.5.1	Broadcast and On-line Services: Search, select, and rightful use of content on personal storage systems ("TV-anytime"); Part4: Phase 1 – Content referencing.
[35] HDCP rev1.4	Digital Content Protection LLC, "High-bandwidth Digital Content Protection System", rev. 1.4, July 8, 2009.



[36] HDMI rev. 1.4b	HDMI Licensing, LLC: HDMI, “High- Definition Multimedia Interface”, rev. 1.4b, October 11 <sup>th</sup> , 2011.
[37] IEC 61169-2	Radio-frequency connectors – Part 2: Sectional specification – Radio frequency coaxial connectors of type 9,52.
[38] ISO/IEC 61169-24 (ISO 169-24)	Radio-frequency connectors – Part 24: Radio-frequency coaxial connectors with screw coupling, typically for use in 75 $\Omega$ cable distribution systems (Type F).
[39] IEC 60603-14	Connectors for frequencies below 3 MHz for use with printed boards – Part 14: Detail specification for circular connectors for low-frequency audio and video applications such as audio, video and audio-visual equipment.
[40] IEC 60958	Digital audio interface – Part 3: Consumer applications.
[41] IEC 61937	Digital audio – Interface for non-linear PCM encoded audio bitstreams applying IEC 60958.
[42] IEEE 802.11	The Working Group for Wireless Local Area Networks (WLANs).
[43] IEEE 802.3	IEEE Standard for Information Technology-Telecommunications and information exchange between systems-Local and metropolitan area networks-Specific requirements Part 3: Carrier Sense Multiple Access with Collision Detection (CSMA/CD) Access Method and Physical Layer Specifications.
[44] IETF RFC 2131	Dynamic Host Configuration Protocol, March 1997.
[45] IETF RFC 2132	DHCP Options and BOOTP Vendor Extensions, March 1997.
[46] IETF RFC 3203	DHCP reconfigure extension, December 2001.
[47] ISO 3166 – Part 1-3	Codes for the representation of names of countries and their subdivisions:  Part 1: Country codes  Part 2: Country subdivision code  Part 3: Code for formerly used names of countries
[48] ISO 8859-1	Information technology – 8-bit single-byte coded graphic character sets – Part 1: Latin alphabet No. 1, 1998.
[49] ISO/IEC 11172-3	ISO/IEC: Information technology – Coding of moving pictures and associated audio for digital storage media at up to about 1,5 Mbit/s – Part 3: Audio.
[50] ISO/IEC 13818 – 1	Information Technology – Generic Coding of Moving Pictures and Associated Audio Information. Part 1: Systems. ISO/IEC International Standard IS 13818.
[51] ISO/IEC 13818-2	Information technology – Generic coding of moving pictures and associated audio information: Video, ISO/IEC International Standard IS 13818.

[52] ISO/IEC 13818 – 3	Information Technology – Generic Coding of Moving Pictures and Associated Audio Information. Part 3: Audio. ISO/IEC International Standard IS 13818.
[53] ISO/IEC 14496-3	ISO/IEC: Information technology – Coding of audio-visual objects – Part 3: Audio, 2009.
[54] ISO/IEC 14496-10:2014 / Rec. ITU-T H.264	ISO/IEC 14496-10 / recommendation ITU-T H 264: Information technology — Coding of audio visual objects — Part 10: Advanced Video Coding, 2014.
[55] ISO/IEC 60958-3 Ed.3.0	ISO/IEC: Digital audio interface – Part 3: Consumer applications, May 25, 2006.
[56] ISO/IEC 7816, 1-3	Identification cards – Integrated circuit cards with contacts, Parts 1-3. ISO/IEC International Standard IS 7816.
[57] ITU-J.122	(EuroDocsis 2.0): Second-generation Transmission Systems for Interactive Cable Television Services – IP Cable Modems.
[58] ITU-J.222.1	(EuroDocsis 3.0): Third-generation Transmission Systems for Interactive Cable Television Services – IP Cable Modems: Physical Layer Specifications (Annex B).
[59] ITU/R Report 624-4	ITU-R Report 624-4:1990, Characteristics of Television Systems.
[60] ITU-R BT.653-3	ITU-R Recommendation BT653-2:1993, Teletext systems.
[61] NorDig RoO	NorDig Rules of Operation ver. 3.1.2, April 2021.
[62] NorDig Test	NorDig Test Specification ver. 3.1.2, April 2021.
[63] Universal Serial Bus	Universal Serial Bus (USB) Specification, Revision 2.0.
[64] CI Plus Specification	CI Plus Specification. Content Security Extensions to the Common Interface. Version 1.4.3 (2017-11), from, CI Plus LLP.
[65] UK DTG D-Book	Digital Terrestrial Television (DTG), Requirements for interoperability, The D-Book 7 Part A, Version 1, March 2011.
[66] ETSI TS 102 831 v1.1.1	Implementation guidelines for a second-generation digital terrestrial television broadcasting system (DVB-T2).
[67] ETSI TS 102 822-3-1 v1.6.1	Broadcast and On-line Services: Search, select, and rightful use of content on personal storage systems ("TV-Anytime"); Part 3: Metadata; Sub-part 1: Phase 1 - Metadata schemas. Version 1.6.1 (2010-07).
[68] ISO 639-2	Codes for the Representation of Names of Languages Part 2: Alpha-3 Code.
[69] ETSI TS 102 822-3-2 v1.6.1	Broadcast and On-line Services: Search, select, and rightful use of content on personal storage systems ("TV-Anytime"); Part 3: Metadata; Sub-part 2: System aspects in a uni-directional environment. Version 1.6.1 (2010-07).

[70] ETSI TS 102 851 v1.2.1	Digital Video Broadcasting (DVB); Uniform Resource Identifiers (URI) for DVB Systems.
[71] EBU R 095	EBU R 95, Recommendation for Safe areas for 16:9 television production July 2016 (or later).
[72] EBU R 128	EBU R 128, Loudness normalisation and permitted maximum level of audio signals.
[73] EBU TECH 3344	EBU – TECH 3344, guidelines for distribution systems in accordance with EBU R 128.
[74] EBU R 068	EBU Technical Recommendation R68-2000, Alignment level in digital audio production equipment and in digital audio recorders, revised year 2000.
[75] EBU TECH 3341	EBU – TECH 3341, Loudness Metering: ‘EBU Mode’ metering to supplement loudness normalisation in accordance with EBU R 128.
[76] ITU-R BS.1770	ITU Recommendation ITU-R BS.1770 Algorithms to measure audio programme loudness and true-peak audio level.
[77] ITU-R BS.1771	ITU Recommendation ITU-R BS.1771, Requirements for loudness and true-peak indicating meters.
[78] IEC 62731	IEC 62731, edition 1.0 (2013-01-29), Text-to-speech for television - General requirements.
[79] HbbTV Test Specification	Test Specification for HbbTV (latest version), note: Available at <a href="http://www.hbbtv.org/resource-library/#testing-information-and-support">http://www.hbbtv.org/resource-library/#testing-information-and-support</a>
[80] ETSI ES 102 796 V1.5.1	Hybrid Broadcast Broadband TV (HbbTV) v2.0.2 (allowed option for NorDig HbbTV IRD instead of v2.0.3 [27] until 1 January 2023.
[81] ETSI EN 302 307-2 V1.1.1	Digital Video Broadcasting (DVB); Second generation framing structure, channel coding and modulation systems for Broadcasting, Interactive Services, News Gathering and other broadband satellite applications; Part 2: DVB-S2 Extensions (DVB-S2X), 2015-02.
[82] ISO/IEC 23008-2 /Rec. ITU-T H.265	ISO/IEC 23008-2 / Recommendation ITU-T H.265: Information technology — High efficiency coding and media delivery in heterogeneous environments Part 2: High efficiency video coding.
[83] ITU-R BT.601	Studio encoding parameters of digital television for standard 4:3 and wide-screen 16:9 aspect ratios.
[84] ITU-R BT.709	Parameter values for the HDTV standards for production and international programme exchange.

[85] ITU-R BT.1700	Characteristics of composite video signals for conventional analogue television systems.
[86] ITU-R BT.1847	1 280 × 720, 16:9 progressively-captured image format for production and international programme exchange in the 50 Hz environment.
[87] ITU-R BT.1886	Reference electro-optical transfer function for flat panel displays used in HDTV studio production.
[88] ITU-R BT.2020	Parameter values for ultra-high definition television systems for production and international programme exchange.
[89] ITU-R BT.2100	Image parameter values for high dynamic range television for use in production and international programme exchange.
[90] ITU-R BT.2390	High dynamic range television for production and international programme exchange.
[91] HDCP rev2.2	Digital Content Protection LLC, “High-bandwidth Digital Content Protection System - Mapping HDCP to HDMI”, rev. 2.2, February 13, 2013 and “Errata to HDCP 2.2 on HDMI Specification”, version 2, February 9, 2015.
[92] ANSI/CTA-861-H	A DTV Profile for Uncompressed High Speed Digital Interfaces.
[93] HDMI rev. 2.0b	HDMI Licensing, LLC: HDMI, “High- Definition Multimedia Interface”, rev. 2.0b, March 2016.
[94] ETSI EN 303 560 V1.1.1	Digital Video Broadcasting (DVB); TTML Subtitling Systems Version 1.1.1 (2018-05).
[95] ITU-R BT.2408	ITU-R, Report; Operational practises in HDR television production.
[96] CI Plus ECP Specification v1.1	CI Plus Specification. Extensions for Enhanced Content Protection, Version 1.2 (2019-05), from CI Plus LLP.
[97] ETSI TS 103 190-1 V1.3.1	Digital Audio Compression (AC-4) Standard; Part 1: Channel based coding.
[98] ETSI TS 103 190-2 V1.2.1	Digital Audio Compression (AC-4) Standard, Part 2: Immersive and personalized audio.
[99] IEC 61937 - 9:2017	Digital audio - Interface for non-linear PCM encoded audio bitstreams applying IEC 60958 - Part 9: Non-linear PCM bitstreams according to the MAT format.
[100] ETSI TS 103 420 v1.1.1	Backwards-compatible object audio carriage using Enhanced AC-3.

[101] IETF BCP 47	Tags for Identifying Languages ( <a href="https://tools.ietf.org/html/bcp47">https://tools.ietf.org/html/bcp47</a> ).
[102] HDMI rev. 2.1	HDMI Licensing, LLC: HDMI, "High- Definition Multimedia Interface", rev. 2.1, November, 2017.
[103] ITU-R BS.205	Advanced sound system for program production.
<b>References only for NorDig RoO specification:</b>	
[104] BBW WHP 198	BBC Research White Paper WHP 198 - Audio Description Studio Signal, August 2011 <a href="https://www.bbc.co.uk/rd/publications/whitepaper198">https://www.bbc.co.uk/rd/publications/whitepaper198</a>
[105] Dolby Metadata Guide	Dolby Metadata Guide Issue 3, details on AC-3 and E-AC-3 metadata. <a href="https://www.dolby.com/us/en/technologies/a-guide-to-dolby-metadata.pdf">https://www.dolby.com/us/en/technologies/a-guide-to-dolby-metadata.pdf</a>
[106] NorDig Unified v.3.1.2	NorDig Unified - Requirements for Integrated Receiver Decoders, Version 3.1.2 April 2021.
[107] Void	Void
[108] ETSI TS 101 162	Digital Video Broadcasting (DVB); Allocation of identifiers and codes for Digital Video Broadcasting (DVB) systems <a href="https://www.etsi.org/deliver/etsi_ts/101100_101199/101162/">https://www.etsi.org/deliver/etsi_ts/101100_101199/101162/</a>
[109] Void	Void
[110] Void	Void
[111] ETSI TS 103 127	Digital Video Broadcasting (DVB); Content Scrambling Algorithms for DVB-IPTV Services using MPEG2 Transport Streams <a href="http://www.etsi.org/deliver/etsi_ts/103100_103199/103127/01.01_60/ts_103127v010101p.pdf">http://www.etsi.org/deliver/etsi_ts/103100_103199/103127/01.01_60/ts_103127v010101p.pdf</a>
[112] ETSI TS 100 289	Digital Video Broadcasting (DVB); Support for use of the DVB Scrambling Algorithm version 3 within digital broadcasting systems <a href="http://www.etsi.org/deliver/etsi_ts/100200_100299/100289/01.02_60/ts_100289v010201p.pdf">http://www.etsi.org/deliver/etsi_ts/100200_100299/100289/01.02_60/ts_100289v010201p.pdf</a>
[113] ETSI TR 101 290	Digital Video Broadcasting (DVB); Measurement guidelines for DVB systems <a href="https://www.etsi.org/deliver/etsi_tr/101200_101299/101290/01.04.01_60/tr_101290v010401p.pdf">https://www.etsi.org/deliver/etsi_tr/101200_101299/101290/01.04.01_60/tr_101290v010401p.pdf</a>

## 1.5 *List of Abbreviations*

AAC	Advanced Audio Coding, according to ISO/IEC 14496-3 [53]
AC-3	Dolby AC-3 audio coding system, according to ETSI TS 102 366 [33]
AC-4	Dolby AC-4 audio coding system, according to ETSI TS 103 190-2 [98]
AFD	Active Format Descriptor
API	Application Programming Interface
BAT	Bouquet Association Table
BCD	Binary Coded Decimal
BER	Bit Error Ratio
bslbf	bit string, left bit first
C/N	Carrier to Noise ratio
CA	Conditional Access
CAT	Conditional Access Table
CENELEC	Comité Européen de Normalisation Électrotechnique
CI	Common Interface
CI+	Common Interface Plus, also CIP
CICAM or CI-Module	Common Interface Conditional Access Module, also CI-CAM, CIP-CAM or CAM
CID	Content Identifier Descriptor
CRC	Cyclic Redundancy Check
CRID	Content Reference Identifier
CSA	Common Scrambling Algorithm, also DVB CSA
CVBS	Composite Video Baseband Signal
DAD	Default Authority Descriptor
dBFS	dB Full Scale
DVB	Digital Video Broadcasting
DVB-C	Digital Video Broadcasting - Cable
DVB-data	Digital Video Broadcasting - Data Broadcasting
DVB-S	Digital Video Broadcasting - Satellite
DVB-T	Digital Video Broadcasting – Terrestrial system
DVB-T2	Digital Video Broadcasting – Terrestrial system, second generation system
E-AC-3	Dolby Enhanced AC-3 audio coding system
EBU	European Broadcasting Union
ECM	Entitlement Control Message
ECP	Enhanced Content Protection
EICTA	European Information & Communications Technology Industry Association
EIT	Event Information Table
EITp/f	Event Information Table, present/following tables
EITsch	Event Information Table, schedule tables
EITp	Event Information Table, present table/section of EITp/f
EITf	Event Information Table, following table/section of EITp/f
EMM	Entitlement Management Message
EPG	Electronic Program Guide
ESG	Event Schedule Guide
GOP	Group of Pictures
HbbTV	Hybrid Broadcast Broadband TV
HDCP	High-bandwidth Digital Content Protection
HDMI	High-Definition Multimedia Interface

HDTV	High Definition Television
HE-AAC	High Efficiency Advanced Audio Codec
HTTP	Hyper Text Transfer Protocol
IDTV	integrated Digital TV, also iDTV
IEC	International Electrotechnical Commission
IEEE	Institute for Electrical and Electronic Engineers
IRD	Integrated Receiver Decoder
ISO	International Organisation for Standardisation
JOC	Joint Object Coding (extension for E-AC-3)
LCD	Logical Channel Descriptor
LCN	Logical Channel Number
MFN	Multiple Frequency Network
MPEG	Moving Pictures Expert Group
NIT	Network Information Table
NorDig	NorDig is specifying a common platform for Digital Television for the Nordic region and Eire.
OSD	On Screen Display
PAL	Phase Alternating Line
PAT	Program Association Table
PID	Packet Identifier
PMT	Program Map Table
PSI	Program Specific Information
PCR	Programme Clock Reference
PVR	Personal Video Recorder, (same as PDR, Personal Digital Recorder or DVR)
QAM	Quadrature Amplitude Modulation
QoS	Quality of Service
QPSK	Quaternary Phase Shift Keying
RF	Radio Frequency
RoO	Rules of Operation
RS	Reed-Solomon
RST	Running Status Table
SDT	Service Description Table
SFN	Single Frequency Network
SI	Service Information
SIT	Selection Information Table
ST	Stuffing Table
STB	Set-top box
TDT	Time and Date Table
TOT	Time Offset Table
TS	Transport Stream
TV	Television
UHF	Ultra-High Frequency
uimbsf	unsigned integer most significant bit first
UTC	Universal Time, Co-ordinated
VHF	Very-High Frequency
VSF	Vestigial Side Band
VOD	Video On Demand
XML	Extensible Mark-up Language

## 2 NorDig Broadcaster distributions network

### 2.1 Introduction

The NorDig Rules of Operation specifies the use of transmit parameters to ensure that they are used in a common way, independent of operator and media. The common rules are established to simplify the implementation of IRDs, especially for cases when independent operators broadcast to the same IRD (in the same network).

NorDig Rules of Operation specifies the minimum requirements for operating a digital tv distribution network defined as a NorDig Broadcaster, supporting NorDig IRDs including cable, satellite, terrestrial and managed IPTV based networks for both live and on demand services.

The NorDig Broadcaster manage and operation the distribution network to the end users / consumers and have the support responsibility for the distribution signals.

NorDig Broadcast distribute digital tv signals directly from the content providers or from other networks and have the total control over the distribution network, from video, audio encoding and metadata signalling to frequency and channel structure.

### 2.2 Broadcast distribution systems (informative)

The “classic tv broadcast chain” is a distribution system where tv signals and related services are typically aggregated by the **Broadcaster** (aka **Content Provider**), distributed by **Network Operator**, (for subscription/PayTV services) packetized by the **Service Operator** down to the **Viewers**. Figure 2.2 shows an overview example of DVB broadcasting distribution technical flow and its main functions (for networks which includes some PayTV services). Here is a short description of the chain, mainly focusing upon the distribution part after the Broadcasters has created the TV services.

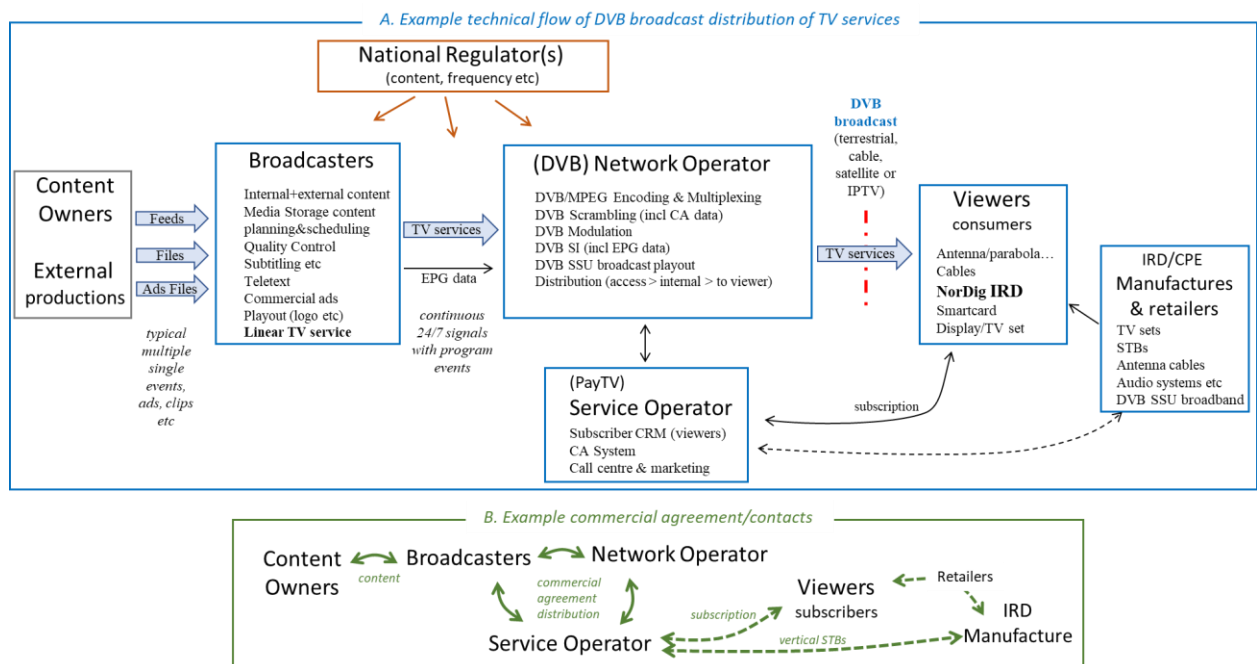

Figure 2.1 Overview example of flow of DVB broadcast distribution of TV services, above (A) typical example technical flow of the TV services while below (B) example of the commercial contacts between parties/roles.



The responsibility and roles vary quite some from one DVB network to another. Examples, some DVB network might only have Free-To-Air/Free-to-View services and then the (PayTV) Service Operator role is then excluded and relevant parts handled by the others, some other DVB networks all services are DVB scrambled (common for satellite networks), some DVB networks it might be the same company for Service and Network Operation, some Broadcasters might handle some of the functions of the network operation themselves (like DVB/MPEG Encoding) while others let the Network Operator handle these parts. Several networks today offer a hybrid service of DVB classical broadcast and broadband distributed services and content.

The **Broadcaster** (Content Provider) stacks program events after each other's (including any promotion, commercial ads and other interstitials etc) to a 24-7 continues flow and packetized into a **TV service** signal out from the "TV studio" (its playout/continuity chain), which is then distributed down to the viewers via various distribution networks, see figure 2.2 below.

The technical part of TV services inside the Broadcaster is often a highly optimised and efficient workflow of creating and collecting content. The Broadcaster often prepare and store many of its non-live program events in advance in its media archive/storage system which is later playback when it is broadcasted on-air. Most TV services today are broadcasting 24-7 daily. TV services with live broadcasted content (news, sports, talk shows) more than 20% of the day (~5 hours/day) are typically classed as having high amount of live content.

For the **Network Operation** part of the TV distribution (for example handled by the Network Operator), multiple TV services are typically compressed (DVB/MPEG encoded), multiplexed together with other TV services into a transport stream (DTT multiplex, Satellite transponder), internally distributed to the various network's modulation sites from where the services are DVB transmitted down to the Viewers see figure 2.x below.

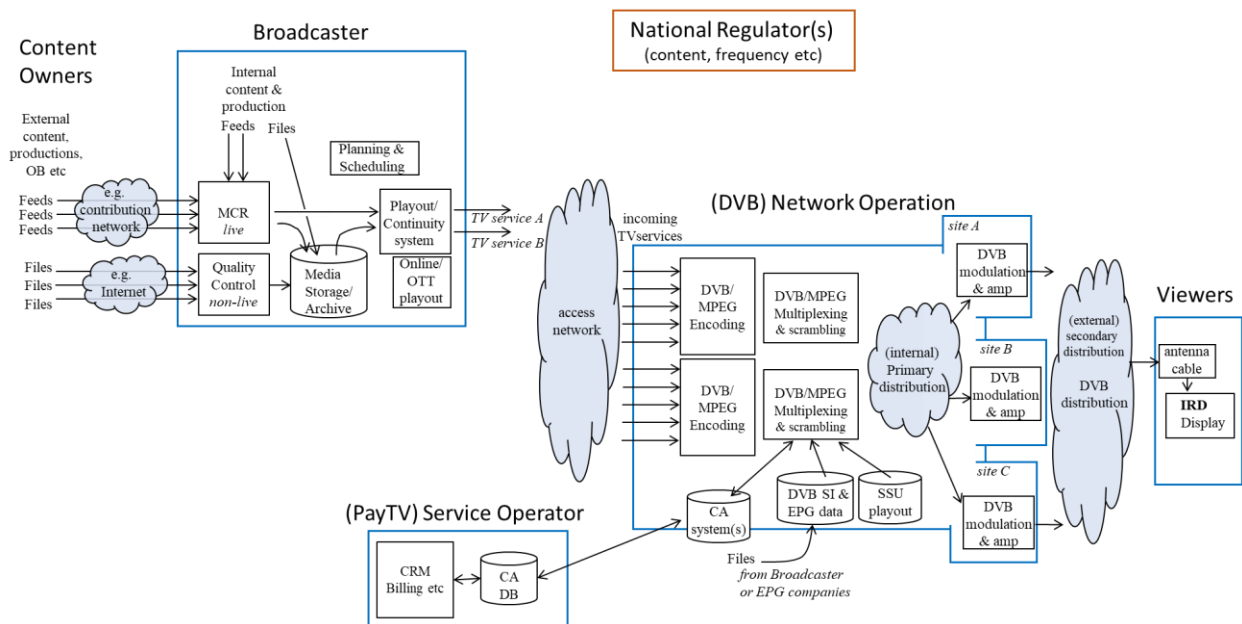

Figure 2.2 Overview example of structure for main parts and distribution of TV services from Content Owners/Providers down to the Viewers. DTT/Terrestrial and cable network often consist of multiple sites for modulation and final transmission (DTT: transmitter sites, cable: cable head-end sites), while satellite often has few or sometimes just a single site for the modulation and final transmission/uplink to the satellite(s).

Below is a more general architecture description of the “classic tv broadcast chain” only for live tv for a **DTT networks**, meant as help for better understanding the NorDig Rules of Operation specifies for who are not in broadcaster industry.

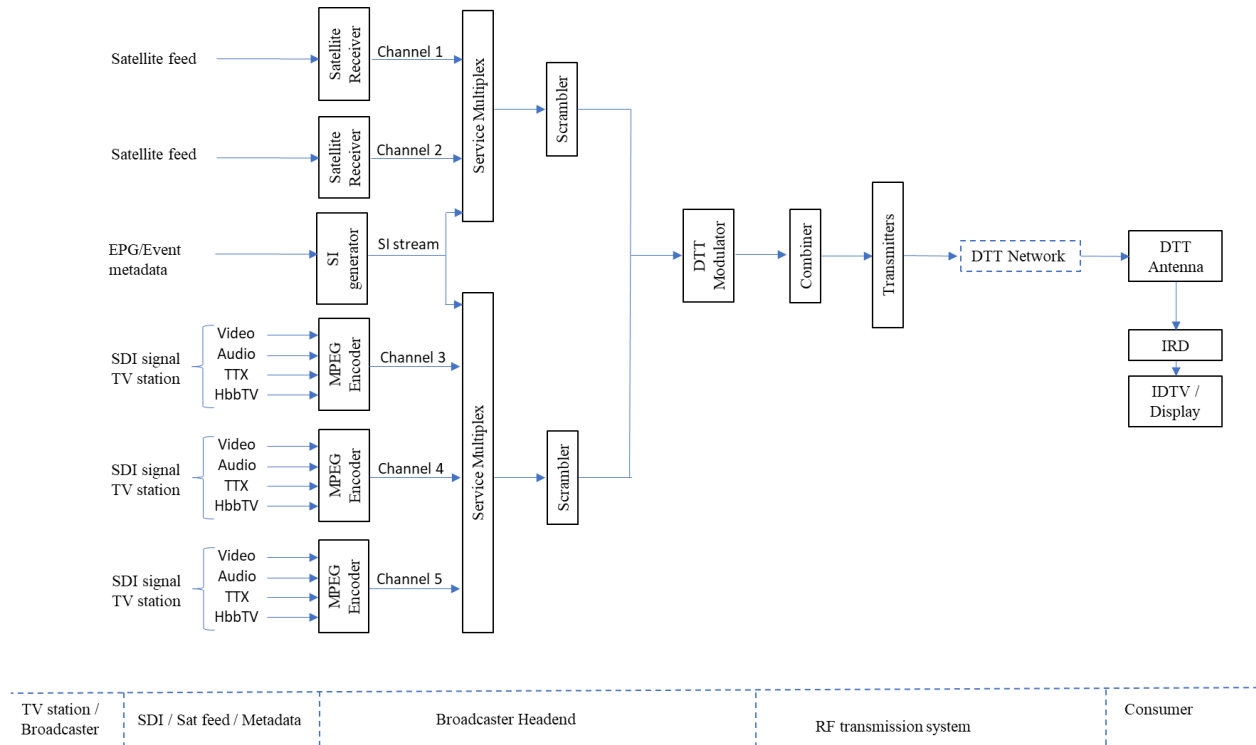

Figure 2.3 Broadcast chain DTT network - General system architecture

The General system architecture is divided in the four subsystems as shown in the figure 2.3:

- Source coding and compression
- Service multiplexing and management
- Modulation and RF transmission
- Consumer signal reception – NorDig IRD

Sources of content and data, some of the used alternatives:

Some Broadcasters (“tv stations”) deliver their TV signals as an uncompressed SDI signal or as an (light) compressed signal (Mezzanine format) via an Access Network to the Network Operation Headend for each of their tv services as a complete feed including Video, Audio, Teletext and subtitling (TTX), HbbTV, Conditional Access Data and metadata. EPG/Event metadata for the tv services are delivered separately to the SI management system and generator.

Some other Broadcasters deliver their TV signals into the DTT network as retransmission from satellite services, for example done via decoding the signals and repacking the tv services in the service structure.

Source coding and compression:

For SDI or Mezzanine light compressed sources for a tv service are encoded and compressed in the DVB/MPEG encoder to decided video /audio formats and bitrate together with associated Teletext and subtitling (TTX), HbbTV, Conditional Access Data.

Each MPEG encoder deliver an MPEG TS containing a complete tv service to the Service Multiplex.

The Multiplex processing the TS / data streams from the MPEG encoders to a “package” including multiple numbers of tv services.

For services that shall be DVB scrambled (not FTA services), the encoded signal from the Multiplexer is encrypted in the DVB Scrambler and internally distributed to all of the DTT network’s transmitter sites into the DTT “modulator” (and similar architecture for Cable and Sat networks) where signals are DVB (DVB-T/-T2) modulated in to correct RF frequencies and make the channels coding.

Modulation:

The DTT modulator (TV transmitter which is contained of an exciter (modulator) plus an amplifier) deliver a high-power RF signal to the Transmission system and the complete tv service including all tv channels are broadcasted via the DTT transmission high transmitting antennas in the DTT network (“high power at high tower”).

Consumers/Viewers:

The consumers/viewers receive the signal from the DTT network over air via a house antenna (or other). The RF signal are demuxed and decoded in the consumer IRD for monitoring / presentation on the display and audio monitors as tv channels.

### 2.3 **Implementation and management**

This NorDig Rules of Operation specifications contains requirement and recommendations for the NorDig Broadcaster described in the following sections to support NorDig IRDs:

Chapter 3 The modulators and tuners of NorDig broadcast

The NorDig Broadcaster will broadcast over one or more of the following media: satellite, cable, terrestrial, IP-based. The NorDig Broadcaster will broadcast over Satellite using DVB-S, DVB-S2 or DVB-S2X, over Terrestrial using DVB-T or DVB-T2, over cable using DVB-C and/or over IP using IPTV.

Chapter 4 MPEG-2 Multiplexing

The NorDig IRD and CA Modules are designed with a minimum MPEG2 TS demultiplexing capability, as defined in NorDig Unified IRD specification section 4.1) which the Network/Operators must take in account. One and the same network may consist of a variety of NorDig IRD and legacy NorDig IRD, each with their own demultiplexing capability.

Chapter 5 Video

This chapters aims to ensure that NorDig broadcasters will transmit video content in a format that will be readily supported by the IRD compliant with NorDig Unified IRD Specification v3.1.2 [106].

Chapter 6 Audio

This section includes several aspects regarding the set-up up of audio parameters within broadcast television and radio services.

Chapter 7 Teletext and Subtitling

DVB Subtitling (ETSI EN 300 743 [17]) and EBU Teletext Subtitling (ETSI EN 300 706 [16]) are mandatory in the NorDig IRDs. NorDig HEVC IRDs shall also support TTML subtitling (ETSI EN 303 560 [94]).

Chapter 9 Conditional Access

NorDig services/content may need to be protected for commercial or legal purposes (typically for Pay TV purposes or geo-blocking in satellite “Free To View”/“free-scrambled” service). Protection is achieved through scrambling of the video, audio and services to be transmitted.

#### Chapter 10 System Software Update (SSU)

The software of the NorDig IRD and of the CIP CAM can be updated by broadcast updates (Over-The-Air/OTA/Over-Air-Download/OAD), and if the NorDig Connected IRD are connected to the open internet, Over-The-Network (OTN).

#### Chapter 12 Service Information

The DVB Service Information (SI) and MPEG Programme Specific Information (PSI) has a very important part for the consumer IRD on how services are decoded and how to present the services.

#### Chapter 14 NorDig PVR

A NorDig PVR is a recordable IRD that fulfils all mandatory requirements specified in NorDig Unified IRD specification.

#### Chapter 15 IRD System Software and API

The NorDig Hybrid IRD will support all mandatory features as defined in the latest released version of the NorDig Unified Requirements. (available from [nordig.org](http://nordig.org)).

NorDig Rules of Operation is structured with chapter numbering same as NorDig Unified Requirements / IRD specification to make easier to use the two specifications together, but there a section in the IRD specifications which are not relevant for the RoO therefore this section / chapter a just marked with “No RoO specification”.

## 3 The modulators and tuners of NorDig broadcast

### 3.1 Common Features

#### 3.1.1 General Features

The NorDig Broadcaster will broadcast over one or more of the following media: satellite, cable, terrestrial, IP-based.

The NorDig Broadcaster will broadcast over Satellite using DVB-S, DVB-S2 or DVB-S2X, over Terrestrial using DVB-T or DVB-T2, over cable using DVB-C and/or over IP using IPTV.

#### 3.1.2 Common Modulations and Framing Procedures

The NorDig Broadcaster transmitting over Satellite, Cable or Terrestrial should ensure the correct Modulation, Channel Coding and DVB framing structure is used to deliver the outgoing transport stream.

The above is not relevant for NorDig Broadcasters transmitting over IPTV.

#### 3.1.3 Reception Quality Detector

Not Applicable for RoO.

### 3.2 Satellite Modulation, Coding and Framing

#### 3.2.1 General

The NorDig Broadcaster transmitting over Satellite should ensure that they broadcast in accordance with both ETSI EN 300 421 [11] (DVB-S) and ETSI EN 302 307 [20] (DVB-S2).

Additionally, the NorDig Broadcaster transmitting content over Satellite may in addition broadcast in accordance with ETSI EN 302 307-2 [20] (DVB-S2X) with the following limitations (targeting NorDig HEVC IRD):

- Channel bonding (as specified in section 5.1.2 in ETSI EN 302 307-2 [20]) is optional.
- 32APSK modes are optional.

Note 1: All other subsystems and functions specified ETSI EN 302 307-2 [20] (DVB-S2X) as “Normative” for receivers used for “Broadcast services” in table 1: “S2X System configurations and application areas” **shall** then be supported.

#### 3.2.2 RF/IF Characteristics

The available transponder bandwidths and transponder powers vary with the different satellites. Consequently, The NorDig Broadcaster transmitting over Satellite may use a range of symbol rates and forward error correction rates that may be employed.

The NorDig Broadcaster transmitting over Satellite should ensure that the outgoing DVB signals complies with ETSI EN 300 421 [11] (DVB-S) or ETSI EN 302 307 [20] (DVB-S2), including QPSK and 8PSK waveforms, or ETSI EN 302 307-2 [81] (DVB-S2X)

The NorDig Broadcaster transmitting over Satellite should ensure that error correction rates, and upconversion are based on the standard roll-off rates specified in `satellite_delivery_system_descriptor` in ETSI EN 300 468 [13].

The NorDig satellite broadcast should use one or more of the following symbol rates on the outgoing carriers:

- QPSK-carrier: From 7.5 MBaud to 45Mbaud (1)

- 8PSK-carrier: From 5 MBaud to 30 MBaud (1)

The NorDig satellite HEVC broadcast using DVB-S2X may in addition use one or more of configurations listed in ETSI EN 302 307-2 [20] (DVB-S2X), Table 1: “S2X System configurations and application areas”, up to and including the 16APSK modes, with the following symbol rates on the incoming carriers:

- 8APSK, 16APSK, 32APSK-carrier: From 5 MBaud to 34MBaud (1)

Note 1: The NorDig broadcaster requiring the use of DVB Common Interface or Common Interface Plus should ensure that the bandwidth supplied for broadcast will be within the restriction of the NorDig IRD Common Interface described in section 9.2.

### 3.2.3 Output Frequency Range/up conversion Range

Alternatively, it may be configured to provide a number of transport streams on a single cable, see section 3.2.5

The NorDig Broadcaster transmitting over satellite should modulate the signal, with characteristics and symbol rate as specified in section 3.2.2, within the IF band 950-2150 MHz.

The signal may then be upconverted into the upper or lower band of either polarisation of the RF transmission, and then be output in the frequency range 10.7 GHz to 12.75 GHz.

### 3.2.4 Demodulation and Error Correction

Not Applicable for RoO.

### 3.2.5 Control Signals

Not Applicable for RoO.

### 3.2.6 Multiplexes/TS organisation

Scanning procedure for retrieving the services available on the network.

The NorDig Broadcaster transmitting over satellite should transmit network information in the NIT according to ETSI TS 300 468 [13], clause 5.2.1.

The NorDig Broadcaster transmitting over satellite should also transmit network information, including updates to the service, over PSI/SI according to ETSI EN 300 468 [13].

The NorDig Broadcaster transmitting over satellite may define its own Network Default Value, to be shared with IRD manufacturers for possible embedding into IRD or for providing to the consumer.

The **network default** values should, for each stored network id, include, see NorDig Unified IRD specification:

- Network id
- Polarisation, frequency, modulation mode and symbol rate for carriers that carry service information about actual and other transport streams.

### 3.2.7 Satellite Tuner Interface and Signal Levels

#### 3.2.7.1 RF Input Connector

Not Applicable for RoO.

#### 3.2.7.2 Signal Level

Not Applicable for RoO.

### 3.2.7.3 Power Supply and Control Signals (to RF unit)

Not Applicable for RoO.

### 3.2.8 Performance

With adjacent carriers of equal power levels, equal symbol rates and with carrier separations as specified above, the satellite NorDig IRD **shall** select a wanted carrier between adjacent carriers, demodulate and correct errors such that the performance specified in Table 3.2 is met with a C/N allowance of 0.4 dB for the adjacent carriers.

## 3.3 **Cable Tuner and Demodulator**

### 3.3.1 General

The NorDig Broadcaster transmitting over cable should ensure they broadcast in accordance with ETSI EN 300 429 [12] (DVB-C), QAM modulated.

The incoming carriers may in addition to the digital carriers include analogue PAL television signals using AM-VSB modulation, as specified in ITU/R Report 624-4 [59], standards PAL-B, PAL-G.

The NorDig Broadcaster transmitting over cable is permitted to broadcast analogue PAL television signals using AM-VSB modulation, as specified in ITU/R Report 624-4 [59], standards PAL-B, PAL-G.

The cable NorDig IRD **shall** be able to operate flawless in a CATV network specified in accordance to EN 60728 and EN 50083-9 [5].

The NordDig Broadcaster transmitting over cable should ensure the transport streams are QAM modulated and upconverted from baseband level to RF.

The NordDig Broadcaster transmitting over cable should transmit analogue PAL TV Services over VHF using a 7MHz frequency raster and in Hyperband and UHF using an 8MHz frequency raster.

The NordDig Broadcaster transmitting over cable should transmit over the whole CATV frequency range using an 8MHz frequency raster.

The analogue signals **shall** be identified by the vision carrier and on a frequency channel allocation basis.

Note: DVB-C2 is specified by DVB and as an ETSI standard. DVB-C2 will be considered for NorDig.

### 3.3.2 RF Characteristics

#### 3.3.2.1 Network characteristics

The cable NorDig IRD **shall** operate with input network and channel RF characteristics as specified in Table 3.1.

Parameter	Type of signal	Value
Input Frequency range:	Digital signals	Full band: 110 - 862 MHz, with centre frequencies in the band 114-858 MHz and with an accuracy of +/- 30 kHz (1)
	Analogue signals	47 - 862 MHz and with an accuracy of centre frequency of +/- 30 kHz
Channel bandwidth:	Digital signals	8 MHz (2)
	Analogue signals	7 and 8 MHz
Input level:	Digital signals	47 - 77dB $\mu$ V at 75 Ohms for 256 QAM 43 - 73 dB $\mu$ V at 75 Ohms for 64 QAM
	Analogue signals	TV/AM-VSB: 57 - 80 dB $\mu$ V at 75 Ohms FM radio: up to 70 dB $\mu$ V at 75 Ohms
Total Input Power (80-862 MHz):	Digital & analogue	<93 dB $\mu$ V at 75 Ohms

Parameter	Type of signal	Value
Carrier-to-Interference ratio for total power (discrete and broadband ingress signals)	Digital & analogue	>52 dB within the channel bandwidth
Composite Second Order (CSO) distortion for analogue modulated carriers	Analogue signals	equal or better than 57 dB
Composite Triple Beat (CTB) distortion for analogue modulated carriers	Analogue signals	equal or better than 57 dB.
Input Impedance:		75 Ohms
Modulation:	Digital signals	16-QAM, 64-QAM, 128-QAM and 256-QAM
Symbolrate:	Digital signals	4.0 Msymbols/s to 7.0 Msymbols/s (2) The rates are set in steps of 1 ksymbols/s
Note 1: An extension of the full band, up to 1 GHz, is being considered for future IRDs		
Note 2: Most cable networks use symbol rates close to 7.0 Msymbols/s or 6.952 Msymbols, as specified for EuroDocsis, see ITU-J. 222.1 <b>Error! Reference source not found.</b> Prior to the modulation, the I and Q signals are required to be square-root raised cosine filtered with a roll-off factor of 0.15. The cable IRD <b>shall</b> perform the inverse signal processing, in order to recover the baseband signal.		

Table 3.1 RF front-end characteristics for NorDig IRDs with a cable front-end.

### 3.3.2.2 Input and bypass connectors

The output impedance **shall** be 75  $\Omega$ .

The NorDig Broadcaster transmitting over cable should ensure that the cable output impedance matches the 75  $\Omega$  of the NorDig IRD.

### 3.3.3 Bypass RF<sub>in</sub> to RF<sub>out</sub>

Not Applicable for RoO.

### 3.3.4 Tuning/Scanning Procedure

The scanning procedure for retrieving the services available on the cable network.

The NorDig Broadcaster transmitting over cable should transmit network information in the NIT according to ETSI TS 300 468 [13], clause 5.2.1.

The NorDig Broadcaster transmitting over cable should modulate the digital carriers in *one or more* modes specified for modulation and in *one or more* symbol rate specified in Table 3.1, and upconvert within the frequency band 114-858MHz.

The NorDig Broadcaster transmitting over cable may define its own Network Default Value, to be shared with IRD manufacturers for possible embedding into IRD or for providing to the consumer.

The *network default* values **shall** for each stored network id include:

- Network id
- Frequency (ies) and modulation mode(s) for carriers that carry service information about actual and other transport streams, see section 3.4.2.
- Symbol rate(s) for the specified carrier(s).

### 3.3.5 Performance Data

Not Applicable for RoO.



### 3.3.6 Spurious Emission

Not Applicable for RoO.

### 3.3.7 Requirements under Cable specific conditions

The cable NorDig IRD **shall** support operations at any levels that may correspond to those in a CATV network conforming to EN60728 and EN 50083 [5], where the loading is flat and where the digital signals have a level of 0 dB (ref) and the analogue signals a level that is 6 dB higher (i.e. the digital signals have a 6 dB back-off (1) from the analogue signals). The values of the individual signals **shall** be within the limits specified in Table 3.1, with a total load up to 93dB $\mu$ V at any IRD input.

Note 1: The back-off is the ratio between the RMS value of the PAL vision carrier level during sync puls interval and the average QAM level.  
The back-off between digital and analogue signals may in practice differ between the various networks, e.g some networks operate with 6 dB back-off for 256 QAM and 10 dB for 64 QAM, while other may operate both 256 QAM and 64 QAM signals with 4 dB back-off.

The cable NorDig IRD **shall** be able to handle DVB-C signals at any levels as specified in this section 3.3, including operation:

- At any carrier frequency, with restrictions as specified of adjacent channels being present, and
- at minimum and at maximum input level (see Table 3.1) of the IRD, and
- with an echo with any of the values specified in Figure 3.1

### 3.3.8 C/N (Es/No) performance for Reference BER

The cable NorDig IRD **shall** have a BER performance better than  $2 \times 10^{-4}$  for the C/N ratios specified below, for all specified input levels:

The NorDig Broadcaster should ensure that the signal at the consumer end is at worst a C/N ratio specified below, to ensure the BER performance of the NorDig IRD is better than  $2 \times 10^{-4}$ .

QAM:	C/N (Es/No):	Comments
256	32.0 dB	when the input receive signal is in the range 54 to 77 dB $\mu$ V
	35.0 dB	when the input receive signal is in the range 47 to 54 dB $\mu$ V
128	29.0 dB	
64	26.0 dB	
16	20.0 dB	

Table 3.2 Minimum performance for cable tuner when  $BER=2 \times 10^{-4}$  before Reed-Solomon error correction. C/N is referred to a noise bandwidth that equals the symbol rate.

### 3.3.9 C/N (Es/No) performance with echo applied

The cable NorDig IRD **shall** perform as specified in Table 3.1, plus an allowance of 1 dB when an echo is applied in accordance with the template in Figure 3.1 below.

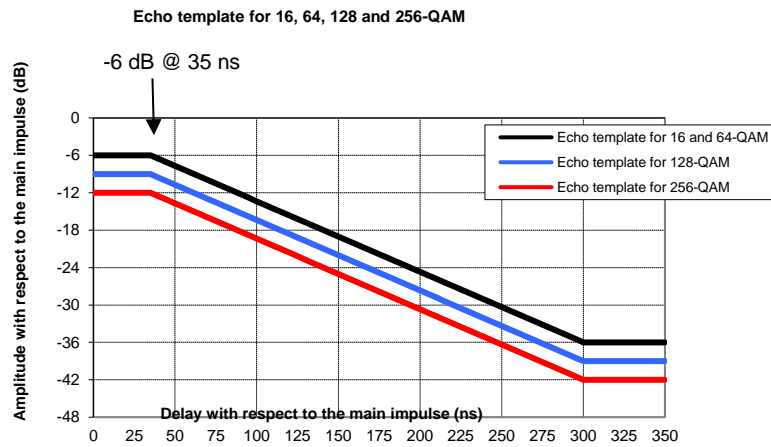

Figure 3.1: Echo template for echoes for 16, 64, 128 and 256-QAM.

### 3.4 Terrestrial Tuner and Demodulator

#### 3.4.1 General

The NorDig Broadcaster transmitting over terrestrial should ensure that they broadcast in accordance with ETSI EN 300 744 [18] if transmitting using DVB-T, and ETSI EN 302 755 [19] if transmitting using DVB-T2.

The digital transmissions may share frequency bands with other transmissions; successful reception will depend on e.g. network configuration, channel characteristics, time-varying interference from other "analogue" or "digital" transmitters and the receiver performance. The transmission networks of DVB-T/T2 may include single frequency networks (SFN).

#### 3.4.2 Frequencies and Signal Bandwidths

##### 3.4.2.1 General

The terrestrial NorDig IRD is required to receive channels in the VHF band III and UHF bands IV, V and should be able to receive channels in VHF S band I, VHF S band II, UHF S Band III (see Table 3.3).

Reminder; Public usage of frequency over air are regulated by National authorities and for NorDig members also by European Union and are under international frequency allocations. The NorDig Broadcaster transmitting over terrestrial **shall** ensure they only use the frequency bands they have been allocated (see Table 3.3 which frequencies are to used for terrestrial use, unless the national authorities have made other allocation for the country).

	Band	Frequency range	NorDig IRD Requirement	Usage in primary DTT network	Potential usage in re-transmission in SMATV cable network
VHF	VHF I	47 – 68 MHz	N/A	N/A	N/A
	S Band I	104 – 174 MHz	Optional	Not used	Potential usage
	VHF III	174 – 230 MHz	Mandatory	Used	May be used
	S Band II	230 – 300 MHz	Optional	Not used	Potential usage
UHF	S Band III	300 – 470 MHz	Optional	Not used	Potential usage
	UHF IV	470 – 606 MHz	Mandatory	Used	May be used
	UHF V	606 – 694 MHz	Mandatory	Used	May be used
	UHF V	694 – 790 MHz	Optional	Not used (1)	Potential usage (1)
	UHF V	790 – 862 MHz	Optional	Not used (1)	Potential usage (1)

Table 3.3: Terrestrial broadcast bands description.

Note 1: The countries for all the NorDig members have by now cleared the 700 MHz and the 800MHz spectrum bands from primary DTT Broadcasting usage. These band are now, in most European countries, primary allocated for Mobile cellular network.

#### 3.4.2.2 Centre Frequencies

The NorDig Broadcaster transmitting over terrestrial should ensure they only use the centre frequency  $f_c$  and the frequency raster (1) for the band they have been allocated. The bands are calculated as below, and a list of bands is available in NorDig Unified 3.1.2 [106] Annex B2.

##### 8 MHz raster:

$$f_c = 114 \text{ MHz} + K * 8 \text{ MHz}, \text{ where}$$

K is an integer number, running from 0 to 72

##### 7 MHz raster:

$$f_c = 107.5 \text{ MHz} + L * 7 \text{ MHz}, \text{ where}$$

L is an integer number, running from 0 to 27.

##### 1.7 MHz raster (DVB-T2):

$f_c$  is specified in NorDig Unified 3.1.2 [106], Annex B2.

Note (1): 6 MHz raster is not used in NorDig Transmission.

#### 3.4.2.3 Maximum Frequency Offset

The NorDig Broadcaster transmitting over terrestrial should ensure they transmit with the appropriate centre frequency offset and should ensure that the offset does not exceed 50 kHz.

#### 3.4.2.4 Signal bandwidths

For a DVB-T signal, an 8 MHz DVB-T signal corresponds to a signal bandwidth of 7.61 MHz and a 7 MHz DVB-T signal corresponds to a signal bandwidth of 6.66 MHz. For 8 MHz DVB-T2 signal, a

normal carrier mode corresponds to a signal bandwidth of 7.61 MHz and an extended carrier mode corresponds to a signal bandwidth of 7.71 MHz for an FFT size of 8K and 7.77 MHz for an FFT size of 16K and 32K.

For a 7MHz DVB-T2 signal, a normal carrier mode corresponds to a signal bandwidth of 6.66 MHz and an extended carrier mode corresponds to a signal bandwidth of 6.80 MHz.

For a 1.7 MHz DVB-T2 signal, a normal carrier mode corresponds to a signal bandwidth 1.54 MHz and an extended carrier mode corresponds to a signal bandwidth of 1.57 MHz.

The NorDig Broadcaster transmitting over terrestrial should ensure, when using DVB-T2, that they signal **the BWT\_EXT** carrier mode indicator field (normal or extended) defined in EN 302 755 [19], clause 7.2.

### 3.4.3 Modes

The NorDig Broadcaster transmitting over terrestrial may, when using DVB-T, use any of the non-hierarchical DVB-T modes specified in EN 300 744 [18] (DVB-T), and may use any combination of constellation (QPSK, 16-QAM or 64-QAM), code rate (1/2, 2/3, 3/4, 5/6 or 7/8), guard interval ( $T_U/4$ ,  $T_U/8$ ,  $T_U/16$  or  $T_U/32$ ) and transmission mode (2K or 8K).

The NorDig Broadcaster transmitting over terrestrial may, when using DVB-T, use any of the hierarchical DVB-T modes specified in EN 300 744 [18] (DVB-T) and Nordig Unified 3.1.2 [106], annex B3, The NorDig Broadcaster transmitting over terrestrial should verify that the NorDig IRD in their network will support the hierarchical DVB-T modes selected.

The NorDig Broadcaster transmitting over terrestrial may, when using DVB-T2, use any allowed configurations, or “DVB-T2 modes”, specified in EN 302 755 [19] (DVB-T2).

- The NorDig Broadcaster transmitting over terrestrial should verify, if they intend to use them, that the NorDig IRDs in their network are able to handle the below configurations, as these configurations are optional for the NorDig IRD: Support for 1.7 MHz bandwidth
- Support for Time Frequency Slicing (TFS)
- Support for 10 MHz bandwidth
- Support for PLPs carrying GS/GSE
- Support for Transmission modes 16K and 32K, when 1.7 MHz RF bandwidth is supported

The NorDig Broadcaster transmitting over terrestrial should, when using DVB-T2 TFS, transmit variable-bit rate PLPs in TFS with a TS peak data rate of up to 15 Mbps, using up to six RF frequencies. Each TS should be split into one data PLP and a common PLP. This should be transmitted over 8 MHz DVB-T2 signals with modulation parameters {32K, 256-QAM, CR=3/5, GI=1/16} on all data PLPs.

Note:

The NorDig broadcaster transmitting over terrestrial may remove the null TS payload packets before transmission.

The NorDig broadcaster transmitting over terrestrial may use a Variable Bit rate PLP, as the TS payload of non-null packets to be transmitted may be variable, and the null packets in the TS are removed before transmission.

The NorDig broadcaster transmitting over terrestrial may use the allowed combinations of the DVB-T2 parameters listed in ETSI EN 302 755 [19]. These constitute the “DVB-T2 mode” and may include:

- Constellation (QPSK, 16-QAM, 64-QAM, 256-QAM), both rotated and non-rotated
- Code rate (1/2, 3/5, 2/3, 3/4, 4/5, 5/6)

- Guard interval (TU/128, TU/32, TU/16, TU\*19/256, TU/8, TU\*19/128, TU/4)
- Transmission mode (1K, 2K, 4K, 8K normal and extended, 16K normal and extended, 32K normal and extended)
- Pilot pattern (PP1, PP2, PP3, PP4, PP5, PP6, PP7, PP8)
- SISO/MISO
- PAPR (No PAPR reduction is used, ACE-PAPR only is used, TR-PAPR only is used, both ACE and TR are used)
- FEC Frame length (64800, 16200)
- Input Mode A (single PLP) or Input Mode B (Multiple PLPs – Common PLP, Type 1 and 2 up to the maximum allowed figure 255)
- Single RF frequency or Time Frequency Slicing (TFS)
- Normal Mode or High Efficiency Mode
- FEF parts (2) (3)
- Auxiliary streams (2)

Note: DVB-T2 transmissions may simultaneously carry both DVB-T2 Base signal and DVB-T2 Lite signal. DVB-T2 Lite signal contained in FEF part of the DVB-T2 Base signal is according to requirements in ETSI EN 302 755 [19] version 1.2.1 or later.

#### 3.4.4 Reception quality/Tuning/Scanning Procedures

##### 3.4.4.1 General

Not Applicable for RoO.

##### 3.4.4.2 Status check: Basic

Not Applicable for RoO.

##### 3.4.4.3 Status check: Advanced

Not Applicable for RoO.

##### 3.4.4.4 Installation mode: Automatic Search, best service

Not Applicable for RoO.

##### 3.4.4.5 Installation mode: Manual Search

Not Applicable for RoO.

##### 3.4.4.6 Requirements for the signal strength indicator (SSI)

Not Applicable for RoO.

##### 3.4.4.7 Requirements for the signal quality indicator (SQI)

Not Applicable for RoO.

#### 3.4.5 Changes in Modulation Parameters

The terrestrial NorDig IRD **shall** automatically recover from changes in the following P1, L1 pre-signalling data and L1 post-signalling parameters at the end of a superframe without a break in the received DVB-T2 signal. An error-free TS **shall** be available within five seconds for any P1 and/or L1 pre-signalling change. An error-free TS **shall** be output within five seconds for any L1 post-signalling FEF change and within two seconds for any other L1 post-signalling change.

The terrestrial NorDig IRD **shall** automatically recover from changes in the following P1, L1 pre-signalling and L1 post-signalling parameters occurring at any time followed by a break in the received signal. An error-free TS **shall** be output within five seconds.

- FFT size
- Bandwidth extension
- Pilot pattern
- Guard interval
- PAPR
- Lf / number of blocks
- Code rate
- Modulation.
- PLP id in case of single PLP,
- T2 System id,
- Cell id
- DVB-T2 version
- adding and/or removing FEF and/or changing proportion FEF length of total frame
- Rotated constellation
- Time interleaving length

The time limits in this clause exclude the time for the DVB-T/T2 modulator to output a stable and valid signal.

#### 3.4.6 RF Input Connector

Not Applicable for RoO.

#### 3.4.7 RF Output Connector (option)

Not Applicable for RoO.

#### 3.4.8 Time Interleaving

The NorDig broadcaster transmitting over terrestrial should not exceed the time interleaving as specified in ETSI EN 302 755 [19] , i.e.  $2^{19} + 2^{15}$  OFDM cells for a data PLP and its common PLP combined.

#### 3.4.9 Input/Output Data Formats

The NorDig broadcaster transmitting over terrestrial should transmit TS of up to 72Mbits/s

Note: The maximum DVB-T2 Transport Stream bit rate is 72 Mbits/s \* 255.  
Deleting the null packets before transmission however removes most of this data.  
The maximum DVB-T2 payload bit rate for all payloads of one transport stream is limited by the DVB-T2 transmission capacity.

#### 3.4.10 Performance

##### 3.4.10.1 General

A wide set of performance requirements is defined for a limited set of DVB-T2 modes, see Table 3.4. A more limited set of performance requirements is defined for a wider set of DVB-T2 modes, as specified elsewhere in this section 3.4.10.

Note: The following performance requirements for DVB-T2 are based on computer simulations plus a reasonable implementation margin. The specified performance figures will be reviewed in a future update of this specification, when more information about realistic receiver performance is available from laboratory and field tests.  
The review may result in modifications of the specified figures and in additional requirements.

	VHF III 7 MHz SFN								VHF III 7 MHz MFN			UHF 8 MHz SFN					UHF 8 MHz MFN	
<b>Transmission mode</b>	32K normal								32K normal			32K extended					32K extended	
<b>Constellation</b>	256-QAM rotated								256-QAM rotated			256-QAM rotated					256-QAM rotated	
<b>Code rate</b>	3/5	2/3	3/4	3/5	2/3	2/3	3/4	3/5	2/3	3/4	3/4	3/5	3/5	2/3	3/5	2/3	3/4	
<b>Guard interval</b>	1/8 1/16	1/8 1/16	1/8 1/16	1/16 1/32	1/16 1/32	19/256	1/16 1/32	1/128	1/128	1/128	1/8	1/16 1/32	19/256	1/16 1/32	1/32	1/128	1/128	
<b>Pilot Pattern</b>	PP2			PP4				PP7			PP2	PP4		PP6	PP7			
<b>PAPR</b>	TR-PAPR								TR-PAPR			TR-PAPR					TR-PAPR	
<b>SISO/MISO</b>	SISO								SISO			SISO					SISO	
<b>FEC Frame length</b>	64800								64800			64800					64800	
<b>Input mode</b>	Mode A								Mode A			Mode A					Mode A	
<b>TFS</b>	No								No			No					No	
<b>Normal mode (NM)/high efficiency mode (HEM)</b>	HEM								HEM			HEM					HEM	
<b>FEF</b>	Not used								Not used			Not used					Not used	
<b>Auxiliary streams</b>	Not used								Not used			Not used					Not used	

Table 3.4: A limited set of DVB-T2 modes for performance requirements (see note above).

#### 3.4.10.2 Definitions

The carrier-to-noise (C/N) ratio in Table 3.5 (DVB-T) and Table 3.6 (DVB-T2), and minimum receiver signal input level ( $P_{min}$ ) values in Table 3.8 (DVB-T) and Table 3.9 Examples of minimum DVB-T2 signal input levels ( $P_{min}$ ) for QEF reception at TS output (with 1/8 guard interval, PP2 and FFT size 32K, Extended bandwidth for UHF) for profiles 1 and 2. For 1.7 MHz modes the  $P_{min}$  figures refer to 1/8 guard interval, PP2 and FFT size 8K with Normal bandwidth (3).

(DVB-T2) are specified for two profiles:

Profile 1: Gaussian noise (N) is applied together with the wanted carrier (C) in a signal bandwidth of a DVB-T or DVB-T2 signal. No echo is applied.

Profile 2: The wanted signal (C) includes the direct path signal and an echo. The echo has the same power (0 dB echo) as the direct path signal and is delayed from 1.95  $\mu$ s to 0.95 times the guard interval length and has 0 degrees phase shift at the channel center.

### 3.4.10.3 C/N Performance

The NorDig broadcaster transmitting over terrestrial should ensure that the NorDig IRD receive their signal will a minimum C/N as described in Table 3.10 for DVB-T and 3.11 for DVB-T2

Note: For DVB-T2 the required C/N for QEF and for error-free video are expected to be virtually identical due to the sharp waterfall characteristic of the LDPC + BCH decoding.

The C/N figures in Table 3.6 (DVB-T2) are derived as follows:

$$C/N = (C/N)_{RAW} + A + B + C + D \text{ [dB]}, \text{ where}$$

- $(C/N)_{RAW}$  = Required raw C/N for BER =  $10^{-6}$  after BCH decoding, according to
- A = 0.1 dB assumed additional C/N to achieve the BER =  $10^{-7}$  before BCH decoding (assumed QEF transport stream after BCH decoding)
- B = correction for pilot boosting as defined in ETSI TS 102 831 [66]
- C = 2.0 dB (PP1 - PP2), 1.5 dB (PP3 - PP4), 1.0 dB (PP5 - PP8). Assumed C/N loss due to real channel estimation, imperfect LDPC decoding and other imperfections not considered part of the back-stop noise.
- D = additional C/N term corresponding to a back-stop noise level at -33 dBc. This term is derived by first calculating the sum of all terms, except D, and then check how much C/N degradation is caused by the -33 dBc backstop noise level. The term D is identical to this degradation. It should be noted that a change of pilot pattern from e.g. PP4 to PP2, which increases C from 1.5 dB to 2.0 dB, will also cause a slight increase of D.

Note: The scheme above defines the required C/N for *all possible T2 configurations*. The C/N figures found in Table 3.5 and minimum power level figures found in Table 3.6 are only examples, applicable for a particular configuration. Changing pilot pattern from PP2 to something else will e.g. normally result in a change of required C/N and  $P_{min}$ .

Modulation	Code rate	C/N performance (dB)	
		Profile 1 : Gaussian	Profile 2 : 0 dB echo
QPSK	1/2	5.1	8.8
QPSK	2/3	6.9	13.7
QPSK	3/4	7.9	17.4
QPSK	5/6	8.9	-
QPSK	7/8	9.7	-
16-QAM	1/2	10.8	13.3
16-QAM	2/3	13.1	17.9
16-QAM	3/4	14.6	22.1
16-QAM	5/6	15.6	-
16-QAM	7/8	16.0	-
64-QAM	1/2	16.5	19.0
64-QAM	2/3	18.7	23.2
64-QAM	3/4	20.2	27.6
64-QAM	5/6	21.6	-
64-QAM	7/8	22.5	-

Table 3.5: Maximum required C/N for QEF reception at TS output for DVB-T signals (with 1/4 guard interval and FFT size 8K) for profiles 1 and 2.



Modulation	Code rate	C/N performance (dB)	
		Profile 1 : Gaussian	Profile 2 : 0 dB echo
QPSK	1/2	3.5	5.2
QPSK	3/5	4.7	6.8
QPSK	2/3	5.6	8.4
QPSK	3/4	6.6	9.8
QPSK	4/5	7.2	-
QPSK	5/6	7.7	-
16-QAM	1/2	8.7	10.9
16-QAM	3/5	10.1	12.7
16-QAM	2/3	11.4	14.3
16-QAM	3/4	12.5	16.3
16-QAM	4/5	13.3	-
16-QAM	5/6	13.8	-
64-QAM	1/2	13.0	16.0
64-QAM	3/5	14.8	18.0
64-QAM	2/3	16.2	19.7
64-QAM	3/4	17.7	22.0
64-QAM	4/5	18.7	-
64-QAM	5/6	19.4	-
256-QAM	1/2	17.0	20.6
256-QAM	3/5	19.4	23.1
256-QAM	2/3	20.8	25.1
256-QAM	3/4	22.9	28.0
256-QAM	4/5	24.3	-
256-QAM	5/6	25.1	-

Table 3.6: Examples of Maximum required C/N for QEF reception at TS output for DVB-T2 signals (with 1/8 guard interval, PP2 and FFT size 32K) for profiles 1 and 2.

For 1.7 MHz modes the C/N figures refer to 1/8 guard interval, PP2 and FFT size 8K with Normal bandwidth.

The C/N defined in Table 3.6 (DVB-T2), generally apply for Input Mode A (single PLP) and Input Mode B (multiple PLPs), including TFS (using 2 to 6 frequencies). For TFS, the level of all RF channels involved, are identical. For TFS, the 0 dB echo profile is also identical on all RF channels.

Note: Performance requirements for TFS modes with unequal levels and with other channel profiles may be defined in a future release.

#### 3.4.10.4 Minimum Receiver Signal Input Levels

The NorDig broadcaster transmitting over terrestrial should ensure that the NorDig IRD in their network are supplied with a noise figure (NF) for supported frequency ranges equal or better than the values in Table 3.7, taking into consideration the noise figure of the complete NorDig IRD. If the NorDig IRD has a RF loopthrough, then this NF applies to the input after the looped-through path, including the attenuation of the looped through path.

	Band	Noise Figure (NF)
VHF	S Band I	10 dB
	VHF III	6 dB (1, 2)
	S Band II	10 dB
UHF	S Band III	10 dB
	UHF IV	6 dB (2)
	UHF V	6 dB (2)

Table 3.7: Maximum noise figures for the terrestrial NorDig IRD.

Note 1: If 1.7 MHz bandwidth is supported (i.e., VHF band III) the NF **shall** be equal or better than 7 dB.  
 Note 2: For DVB-T signals (EN 300 744 **Error! Reference source not found.**) the NF **shall** be equal or better than 7 dB.

The terrestrial NorDig IRD **shall** provide QEF reception for the minimum signal levels ( $P_{\min}$ ) for the supported frequency range as stated below (at 290K).

For 7 MHz Normal Bandwidth DVB-T/signal:  $P_{\min} = -105.7 \text{ dBm} + \text{NF} [\text{dB}] + \text{C/N} [\text{dB}]$ , and

For 8 MHz Normal Bandwidth DVB-T/T2signal:  $P_{\min} = -105.2 \text{ dBm} + \text{NF} [\text{dB}] + \text{C/N} [\text{dB}]$  and

For 1.7 MHz Normal Bandwidth DVB-T2 signal:  $P_{\min} = -112.1 \text{ dBm} + \text{NF} [\text{dB}] + \text{C/N} [\text{dB}]$ , and

For 7 MHz Extended Bandwidth DVB-T2 signal:  $P_{\min} = -105.7 \text{ dBm} + \text{NF} [\text{dB}] + \text{C/N} [\text{dB}]$ , and

For 8 MHz Extended Bandwidth DVB-T2 signal:  $P_{\min} = -105.1 \text{ dBm} + \text{NF} [\text{dB}] + \text{C/N} [\text{dB}]$ , and

For 1.7 MHz Extended Bandwidth DVB-T2 signal:  $P_{\min} = -112.1 \text{ dBm} + \text{NF} [\text{dB}] + \text{C/N} [\text{dB}]$ ,

where

$P_{\min}$  values are listed in Table 3.8 (DVB-T) and examples of  $P_{\min}$  values are listed in Table 3.9 (DVB-T2) below as calculated from the equations above together with NF values in Table 3.7 plus C/N values in Table 3.8 (DVB-T) and Table 3.9 (DVB-T2). The values in Table 3.8 show the required  $P_{\min}$  values. For all other DVB-T2 modes the terrestrial NorDig IRD **shall** fulfil  $P_{\min}$  requirements, accordingly, based on the formulas above.

		Minimum input level (dBm)					
		Profile 1: Gaussian				Profile 2: 0 dB echo	
Frequency band		VHF Band III	VHF S Band I & II	VHF S Band I & II and UHF S Band III	UHF Band IV&V	VHF Band III	UHF Band IV&V
Modulation	Code Rate	7 MHz signal	7 MHz signal	8 MHz signal	8 MHz signal	7 MHz signal	8 MHz signal
QPSK	1/2	-93.6	-90.6	-90.1	-93.1	-89.9	-89.4
QPSK	2/3	-91.8	-88.8	-88.3	-91.3	-85.0	-84.5
QPSK	3/4	-90.8	-87.8	-87.3	-90.3	-81.3	-80.8
QPSK	5/6	-89.8	-86.8	-86.3	-89.3	-	-
QPSK	7/8	-89.0	-86.0	-85.5	-88.5	-	-
16-QAM	1/2	-87.9	-84.9	-84.4	-87.4	-85.4	-84.9
16-QAM	2/3	-85.6	-82.6	-82.1	-85.1	-80.8	-80.3
16-QAM	3/4	-84.1	-81.1	-80.6	-83.6	-76.6	-76.1
16-QAM	5/6	-83.1	-80.1	-79.6	-82.6	-	-
16-QAM	7/8	-82.7	-79.7	-79.2	-82.2	-	-
64-QAM	1/2	-82.2	-79.2	-78.7	-81.7	-79.7	-79.2
64-QAM	2/3	-80.0	-77.0	-76.5	-79.5	-75.5	-75.0
64-QAM	3/4	-78.5	-75.5	-75.0	-78.0	-71.1	-70.6
64-QAM	5/6	-77.1	-74.1	-73.6	-76.6	-	-
64-QAM	7/8	-76.2	-73.2	-72.7	-75.7	-	-

Table 3.8: Minimum DVB-T signal input levels ( $P_{min}$ ) for QEF reception at TS output (with 1/4 guard interval and FFT size 8K) for profiles 1 and 2.

		Minimum input level (dBm)								
		Profile 1: Gaussian					Profile 2: 0 dB echo			
Frequency band		VHF Band III		VHF S Band I & II	VHF S Band I & II and UHF S Band III		UHF Band IV&V	VHF Band III		UHF Band IV&V
Modulation	Code Rate	1.7 MHz signal	7 MHz signal	7 MHz signal	8 MHz signal	8 MHz signal	1.7 MHz signal	7 MHz signal	8 MHz signal	
QPSK	1/2	-101.6	-96.2	-92.2	-91.6	-95.6	-99.9	-94.5	-93.9	
QPSK	3/5	-100.4	-95.0	-91.0	-90.4	-94.4	-98.3	-92.9	-92.3	
QPSK	2/3	-99.5	-94.1	-90.1	-89.5	-93.5	-96.7	-91.3	-90.7	
QPSK	3/4	-98.5	-93.1	-89.1	-88.5	-92.5	-95.3	-89.9	-89.3	
QPSK	4/5	-97.9	-92.5	-88.5	-87.9	-91.9	-	-	-	
QPSK	5/6	-97.4	-92.0	-88.0	-87.4	-91.4	-	-	-	
16-QAM	1/2	-96.4	-91.0	-87.0	-86.4	-90.4	-94.2	-88.8	-88.2	
16-QAM	3/5	-95.0	-89.6	-85.6	-85.0	-89.0	-92.4	-87.0	-86.4	
16-QAM	2/3	-93.7	-88.3	-84.3	-83.7	-87.7	-90.8	-85.4	-84.8	
16-QAM	3/4	-92.6	-87.2	-83.2	-82.6	-86.6	-88.8	-83.4	-82.8	
16-QAM	4/5	-91.8	-86.4	-82.4	-81.8	-85.8	-	-	-	
16-QAM	5/6	-91.3	-85.9	-81.9	-81.3	-85.3	-	-	-	
64-QAM	1/2	-92.1	-86.7	-82.7	-82.1	-86.1	-89.1	-83.7	-83.1	
64-QAM	3/5	-90.3	-84.9	-80.9	-80.3	-84.3	-87.1	-81.7	-81.1	
64-QAM	2/3	-88.9	-83.5	-79.5	-78.9	-82.9	-85.4	-80.0	-79.4	
64-QAM	3/4	-87.4	-82.0	-78.0	-77.4	-81.4	-83.1	-77.7	-77.1	
64-QAM	4/5	-86.4	-81.0	-77.0	-76.4	-80.4	-	-	-	
64-QAM	5/6	-85.7	-80.3	-76.3	-75.7	-79.7	-	-	-	
256-QAM	1/2	-88.1	-82.7	-78.7	-78.1	-82.1	-84.5	-79.1	-78.5	
256-QAM	3/5	-85.7	-80.3	-76.3	-75.7	-79.7	-82.0	-76.6	-76.0	
256-QAM	2/3	-84.3	-78.9	-74.9	-74.3	-78.3	-80.0	-74.6	-74.0	
256-QAM	3/4	-82.2	-76.8	-72.8	-72.2	-76.2	-77.2	-71.7	-71.1	
256-QAM	4/5	-80.8	-75.4	-71.4	-70.8	-74.8	-	-	-	
256-QAM	5/6	-80.0	-74.6	-70.6	-70.0	-74.0	-	-	-	

Table 3.9: Examples of minimum DVB-T2 signal input levels ( $P_{min}$ ) for QEF reception at TS output (with 1/8 guard interval, PP2 and FFT size 32K, Extended bandwidth for UHF) for profiles 1 and 2. For 1.7 MHz modes the  $P_{min}$  figures refer to 1/8 guard interval, PP2 and FFT size 8K with Normal bandwidth (3).

The NorDig broadcaster transmitting over terrestrial should consider  $P_{min}$  values as applied generally for Mode A and Mode B, including TFS (4), when supported.

For TFS, the levels of all RF channels involved are identical. For TFS, the 0 dB echo profile is also identical on all RF channels.

Note 3: The  $P_{\min}$  values for 1.7 MHz have been calculated using a NF of 7 dB (See note 1 to Table 3.8)

Note 4: Performance requirements for TFS modes with unequal levels and with other channel profiles may be defined in a later release of this specification.

#### 3.4.10.5 Maximum Receiver Signal Input Levels

The NorDig broadcaster transmitting over terrestrial should ensure the NorDig IRD in their network are supplied with a noise figure (NF) of up to a level of  $-35$  dBm for supported frequency ranges for DVB-T and DVB-T2.

The DVB-T signal input level is valid for the modes {8K, 64-QAM,  $R = 2/3$ ,  $\Delta/Tu = 1/8$ }, {8K, 64-QAM,  $R = 2/3$ ,  $\Delta/Tu = 1/4$ } and {8K, 64-QAM,  $R = 3/4$ ,  $\Delta/Tu = 1/4$ }.

The DVB-T2 signal input level is valid for the modes shown in Table 3.9.

#### 3.4.10.6 Immunity to DVB-T/-T2 signals in Other Channels

Not Applicable for RoO.

#### 3.4.10.7 Immunity to 700MHz LTE signals in Other Channels

##### 3.4.10.7.1 General about Immunity to 700 MHz and 800 MHz LTE signals

*In many European countries frequency range from 694 MHz to 790 MHz and 790 MHz to 862 MHz, is or will be used for “700MHz” and “800MHz” mobile services (in the passed these bands was used for terrestrial TV broadcasting).*

*Today mobile telephone network operators use the LTE technology for 4G (or later technologies like 5G) mobile telephone systems on in the “700MHz” and “800MHz” frequency range.*

*For the 700MHz band, the frequency range from 703 MHz to 733 MHz is used for transmission from user equipment (UE) and the frequency range from 758 MHz to 788 MHz is used for transmission from base station (BS). In the duplex frequency gap between up- and downlink, some nations may in addition use transmission of Supplemental Downlink (SDL). Allocated frequency ranges are divided into 5 MHz blocks, but most common implementation is expected to use  $2 \times 5$  MHz block and is therefore using 10 MHz system bandwidth of LTE signal. Frequency allocation for 10 MHz block is illustrated in the figure below.*

*More informative for the 800 MHz band the frequency range from 791 MHz to 821 MHz is used in LTE system for transmission from base station (BS) and frequency range from 832 MHz to 862 MHz is used for transmission from user equipment (UE). Allocated frequency ranges are divided into 5MHz blocks, but most common implementation is expected to use  $2 \times 5$  MHz blocks and is therefore using 10 MHz system bandwidth of LTE signal. Frequency allocation for the Frequency Division Duplex (FDD) arrangement is illustrated in the figure below.*

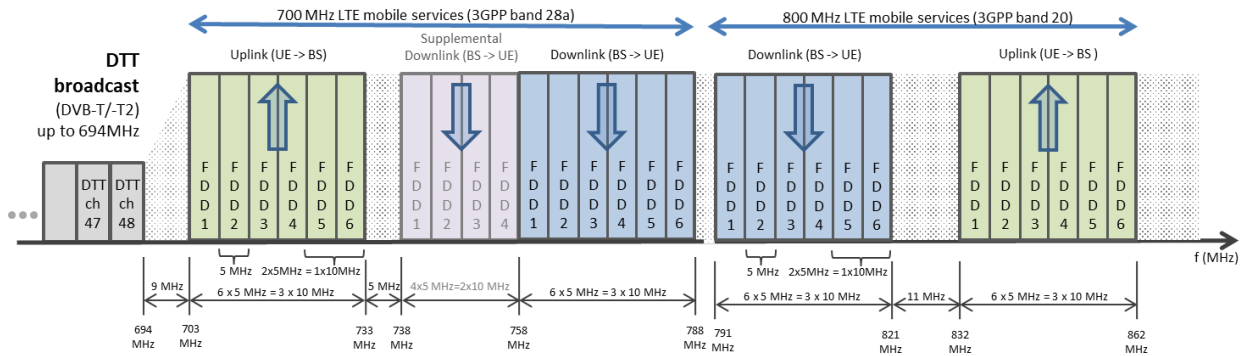

Figure 3.2: Illustration of “700MHz” and "800 MHz" LTE mobile communication network services frequency use (3GPP band 20).

*The EU Directive 2014/53/EU (RED) requires in article 3.2 that: “Radio equipment shall be so constructed that it both effectively uses and supports the efficient use of radio spectrum in order to avoid harmful interference”. Requirements on the broadcast receivers are specified in the ETSI Harmonized European Standard EN 303 340).*

*The ETSI standard is limited to requirements only for the first adjacent selectivity channel in case of LTE interference, while NorDig adds requirements for the IRD’s whole operating frequency range, supplemental downlink and for some cases slightly stricter. But in addition to NorDig the ETSI standard also includes blocking and overloading.*

### 3.4.10.7.2 Immunity to 700 MHz LTE signals in Other Channels

The NorDig broadcaster transmitting over terrestrial should be aware that telecom broadcasting in the 700 MHz range may occur in their network.

The NorDig broadcaster transmitting over terrestrial should ensure the NorDig IRD in their network are resilient, or can be associated with a filter which will reduce interference of the telecom broadcasting with a minimum interference to signal level ratio (I/C) as stated in the Table 3.13 while maintaining QEF reception.

The power of the interfering LTE signal, both BS and UE, varies with a traffic load and traffic type. The signal power of the LTE signal is defined as the power during the active part of the time varying LTE signal, referred to as the licensed power level (I).

Band	Channel	DVB-T or DVB-T2 System	Signal Bandwidth and Channel frequency	Minimum I/C (dB) for terrestrial NorDig IRDs			Minimum I/C (dB) for terrestrial NorDig IRDs that		
				10 MHz Uplink, (FDD1&2)	10 MHz Uplink (FDD3&4, FDD5&6)	10 MHz Downlink (FDD1&2, FDD3&4, FDD5&6, SDL1&2, SDL3&4)	10 MHz Uplink, (FDD1&2)	10 MHz Uplink (FDD3&4, FDD5&6)	10 MHz Downlink (FDD1&2, FDD3&4, FDD5&6, SDL1&2, SDL3&4)
VHF III,	K5-K12	DVB-T	7	46	46	46	48	48	48
UHF IV,	K21-K37	DVB-T	8	46	46	46	48	48	48
UHF V,	K38-K47	DVB-T	8	43	43	46	44	45	48
UHF V,	K48	DVB-T	8	33	43	46	42	45	47
VHF III,	K5-K12	DVB-T2	7	46	46	46	48	48	48
UHF IV,	K21-K37	DVB-T2	8	46	46	46	48	48	48
UHF V,	K38-K47	DVB-T2	8	43	43	46	44	45	48
UHF V,	K48	DVB-T2	8	38	43	46	42	45	47

Table 3.13: Minimum required I/C for QEF reception with interfering 700MHz LTE signal on the adjacent and other channels. I/C values are defined for LTE signals having signal bandwidth of 9.015 MHz in 10 MHz LTE system.

The above values assume:

for DVB-T, to following modes {FFT size, modulation, code rate, guard interval, bandwidth};

- {FFT = 8K, M = 64-QAM, CR = 2/3, GI = 1/8, B = 8MHz},
- {FFT = 8K, M = 64-QAM, CR = 2/3, GI = 1/4, B = 8MHz} and
- {FFT = 8K, M = 64-QAM, CR = 3/4, GI = 1/4, B = 8MHz}

and for DVB-T2 to the modes {FFT size, modulation, pilot pattern, code rate, guard interval, bandwidth}

- {FFT = 32KE, M = 256-QAM R, PP = 4, CR = 2/3, GI = 1/16, 8MHz},
- {FFT = 32KE, M = 256-QAM R, PP = 4, CR = 3/5, GI = 19/256, 8MHz},
- {FFT = 32KN, M = 256-QAM R, PP = 4, CR = 2/3, GI = 19/256, 7MHz}

FFT size 32KE refers to FFT size 32k with extended carrier mode, while 32KN refers to FFT size 32k with normal carrier mode. Modulation 256-QAM R refers to 256 QAM with rotated constellation.

#### 3.4.10.8 Performance in Time-Varying Channels

Not Applicable for RoO

#### 3.4.10.9 Synchronisation for varying echo power levels in SFN

Not Applicable for RoO

#### 3.4.10.10 C/(N+I) Performance in Single Frequency Networks

The NorDig broadcaster transmitting over terrestrial should be aware that Single Frequency Networks may cause one or more FFT window positions on the NorDig IRD for the time synchronisation. This could give an aggregate available C/(N+I) larger than or equal to the required EPT (Effective Protection Target).

The NorDig broadcaster transmitting over terrestrial should ensure that this situation is managed by the NorDig IRD in their network.

#### 3.4.10.11 Time-Frequency Slicing (TFS)

The NorDig broadcaster transmitting over terrestrial may support TFS performed on a combination of UHF band IV/V frequencies (8 MHz channel spacing) and VHF band III frequencies (7 MHz spacing).

The NorDig broadcaster transmitting over terrestrial should ensure that the following conditions are fulfilled:

- The RF signals on VHF have nominally the same modulation parameters as those on UHF, including T2 frame length, symbol time, guard interval etc.
- The edge carriers on the VHF signal are symmetrically suppressed already from the transmitter (e.g. by setting the corresponding FFT bin values to zero) so that the actually transmitted RF bandwidth of the VHF signal is identical to a standard 7 MHz DVB-T2 signal.

Note: In a future release more detailed performance information for TFS operation may be included.

### 3.5 IP-based Front-End

#### 3.5.1 General

Not Applicable for RoO.

#### 3.5.2 Network Interface

The NorDig broadcaster transmitting over IP should ensure that the below parameters are followed:

- RTP Packet Jitter not exceeding 40 ms peak-to-peak ETSI TS 102 034 [29], section 7.2.1 / (ISO/IEC 13818-9).
- Transmission of an SPTS from the network with a speed not exceeding 20 Mbps.
- Transmission of an MPTS with a speed not exceeding 60 Mbps for NorDig IRD in their network capable to receive MPTS.
- - Reception of data from the NorDig IRD with a speed of no less than 2 Mbps.
- - Protocols specified in section 3.5.3 are used.

#### 3.5.3 Protocol Suite

The NorDig broadcaster transmitting over IP should use protocols in compliance with ETSI TS 102 034 [29], Section 4.1.3, including support of IP, RTP and UDP.

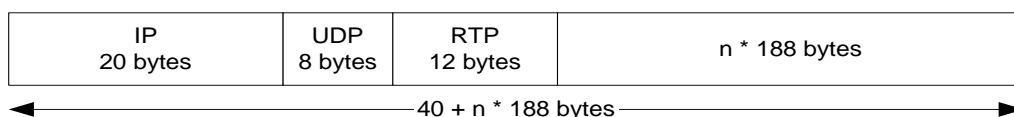

Figure 3.2 Transport stream protocol mapping.

The NorDig broadcaster transmitting over IP may use RTCP as detailed in ETSI TS 102 034 [29].

When RTCP is used, The NorDig broadcaster transmitting over IP should not receive receiver reports (and is thus restricted only to broadcast sender reports).



The NorDig broadcaster transmitting over IP should not use full duplex operation of the access network.

#### 3.5.4 Dynamic Address Allocation

The NorDig broadcaster transmitting over IP should ensure that the networking operates with NorDig IRD dynamically allocated their IP address, and provided with subnet mask, default gateway, DNS server address and possibly WINS/NetBIOS server dynamically assigned from the network via DHCP.

The NorDig broadcaster transmitting over IP should ensure the NorDig IRD are not allocated a Static IP address.

There **shall** be a DHCP client in the IRD that **shall** support all the messages of RFC 2131 [44] and RFC 2132 [45]. The DHCP client **shall** support client reconfiguration as defined in RFC 3203 [46], meaning that the “FORCERENEW” message **shall** be implemented to allow the DHCP server to reconfigure the IP address of NorDig IRD as part of Network Provisioning.

The NorDig broadcaster transmitting over IP should use MAC address of the network interface of the NorDig IRD as the client identifier.

The DHCP client **shall** support all DHCP Options marked as ‘Mandatory’ ETSI TS 102 034 [29], section 8.1.1.4 and Table 17.

#### 3.5.5 Service Selection

Not Applicable for RoO.

*Old text from NorDig RoO ver. 2.5, chapter 3 “The modulators and tuners of NorDig Broadcaster” moved to Annex D.*

## 4 MPEG-2 Multiplexing

### 4.1 General Multiplexing

The NorDig IRD and CA Modules are designed with a minimum MPEG2 TS demultiplexing capability, as defined in NorDig Unified IRD specification section 4.1) which the Network/Operators must take in account. One and the same network may consist of a variety of NorDig IRD and legacy NorDig IRD, each with their own demultiplexing capability.

Network operators targeting NorDig IRDs which have been designed using different versions of the NorDig Unified Requirements or older NorDig specifications, may need to ensure that their transmission/encoding keeps supporting the parameters required for their reception by these IRD.

Network operators may already be adjusting their transmission to support the variety of NorDig IRD including legacy devices and these deviations or workarounds are not covered in this document but should be reviewed on an ongoing basis.

The multiplexing into the MPEG-2 transport layer **shall** be compliant to ISO/IEC 13818-1 [50] (MPEG2 Systems), ETSI TS 101 154 [26] and with the additional requirement stated below:

- The MPEG-2 Service Information as specified in the present document in sections 6, 12 and 13), NorDig Unified 3.1.2 [106], ETSI EN 300 468 [13] (DVB SI)
- For Pay TV DVB scrambled services, the CA descriptor as specified in ETSI TS 100 289 [112].
- The data rates/bitrate of the MPEG-2 transport stream **shall** not exceed the capability of the front end of this network's NorDig IRD, including legacy IRD, as described in section 3, and the Common Interface bandwidth as described in section 9 of this document, NorDig Broadcasters are recommended to include stuffing/NULL packets in transport stream for downstream equipment in the transmission chain, as it is common that system/equipment processing and passing MPEG transport streams in the signal chain needs some headroom
- A single service of TV, Radio or other **shall** be limited to 32 PID (32 Elementary Streams) (1).
- As some NorDig IRD and/or CA systems may only support the minimum of 6 simultaneous stream descrambling, it is highly recommended to limit the encryption to a maximum of 6 different access rights and 6 PID (6 Elementary Streams, each with a different access rights) per Pay TV service, as described in section 4.2 of this document.
- The MPEG-2 Transport Stream may be composed of a mixture of service types (i.e. MPEG-2 SDTV service, MPEG-4 AVC SDTV and HDTV, HEVC based and Radio services may be multiplexed into the same transport stream).
- Newer codecs (MPEG-4 AVC, HEVC) enable better compression and performance than older Codec (MPEG-2). The newer modulation schemes (DVB-T2, S2 etc) are generally available in the NorDig IRD at the same time as these newer codecs. NorDig Broadcasters are recommended to launch the newer codecs when the newer modulation schemes are launched as they make a more optimal use of the spectrum.
- Multiplexing of audio streams as specified in section 6.4 of the present document.

Changing video and/or audio codec, and/or subtitle format, within the same service should only be made between program events (as described in section 5.6 (video), section 6 (audio), section 7 (subtitles) of the present document), or when the service is off-air or outside main broadcast hours (2).

Note (1): Legacy IRDs may support a lower maximum number of simultaneous streams/PID for one service.

Note (2): Transitions may cause transient artefacts during decoding, which may be more or less noticeable depending on the level of support of dynamic switching in the IRD, and the nature of the transition.

## 4.2 DVB scrambling

DVB scrambling of PayTV services has following rules of operation:

- The DVB scrambling **shall** be based on the common scrambling algorithm as specified by DVB, see ETSI TS 100 289 [112] (DVB-CSA3) and its equivalent for DVB-CSA1 and 2. Please note that this reference, and that of DVB-CSA2 are changing at the time of writing this document as custodianship is changing from ETSI to SISVEL, and the latest and up to date version should be sought. The selection of the algorithm is expected to be mandated by the CA Vendor, in accordance with the requirement from the Content Owners.
- PayTV services should not have more 6 different scrambled streams/PIDs (either PES or transport level scrambling) with different access conditions, as the NorDig IRD may only implement the minimum required of 6 defined in section 4.2, and possibly CA systems may have restrictions.
- As some NorDig IRD and/or CA systems may only support the minimum of 6 simultaneous stream descrambling, it is highly recommended to limit the encryption to a maximum of 6 different access rights and 6 PID (6 Elementary Streams, each with a different access rights) per Pay TV service, as described in section 4.2 of this document.
- DVB scrambling may be done in either at transport level or at PES level. (Advantages with using scrambling at PES level is that monitoring/measurement on the transmission side can be done more easily for example for time stamps etc).
- DVB Simulcrypt enables the use of several CA Systems for the same scrambled service/stream/PID.
- For DVB CSA scrambled services/streams/PID the current used keys/control words should be carried in ECM stream/PID, normally one ECM stream per CA System.
- **Repetition rates of ECM:** It is recommended to not have longer repetition intervals of ECM than 0.4 seconds, however DVB basic recommendation of 0.1s would result in high bandwidth. repetition rates of ECM effects zapping time inside the IRD. Simulcrypting multiple CA Systems with multiple ECM streams/PIDs can result in excessive bandwidth needed for these ECM streams. Lowering the ECM repetition rate can sometimes be a reasonable trade-off to keep bandwidth from increasing too much., For example a single ECM for a stream/service, sent with repetition rate of 10 times/s (0.1s intervals) costs 15 kbps bitrate. When simulcasting with four ECMs per stream/service every 0.1s costs 60 kbps, but via lowering repetition rate to 0.3s reduces bitrate to 20 kbps. This example of extending the repetition rate from 0.1s to 0.3s cost just half of the difference in time in average extra zapping time for the viewers (i.e. +0.1s longer zapping time in average).
- **Signalling:** Broadcast DVB ECM streams/PIDs **shall** be signalled in the PMT and broadcast DVB EMM streams/PIDs **shall** be signalled in the CAT. (For CA system using broadband channel for distributing the user rights/EMMs, it up to the CA Vendor to define if signalling in CAT is needed). Scrambled services should normally be signalled in SDT as scrambled (ca\_identifier\_descriptor). In EIT, it often is of little value in signal scrambled services in EIT as scrambled, compared to the extra amount of data needed to be carried in EIT to static signalise this.

For more Rules of Operation (related SmartCard reader and CommonInterface) see section 9 below.

Note: ETSI (or Sisvel) acts as a neutral custodian for the distribution of the system information concerning the common scrambling system

Note: Simlcripting refers to the encryption of a single service or stream using multiple CAS, to enable the ability for this service to be decrypted using any of the participating CA (each using their own rules for enabling decryption). DVB Simulcrypt is a DVB defined standard professional interface between the scrambler/multiplexer and the CA System. **Multicrypt** here refers to when the IRD is equipped and can handle several CA System for different services.

### 4.3 ***System Time Clock/Program Referencs (PCR)***

PCR jitter (PCR accuracy error) should be within DVB Measurement guidelines (ETSI TR 101 290 [113]) before the transmission point to the viewers' IRDs (i.e., PCR jitter within the MPEG TS should be less than 500ns).

## 5 Video

This chapter aims to ensure that NorDig broadcasters will transmit video content in a format that will be readily supported by the IRD compliant with NorDig Unified IRD Specification v3.1.2 [106], section "5. Video".

### 5.1 **General requirements**

The video resolutions and encoding standards required or supported are defined in NorDig Unified specification 3.1.1 IRD, section "2.3.14. Main hardware/firmware functions-Overview per configuration".

In short, multiple different types of IRD may exist (1):

- NorDig Basic IRD support: MPEG-2 SD; MPEG-4 AVC SD and HD mandatory
- NorDig HEVC IRD support: MPEG-2 SD; MPEG-4 AVC SD and HD; MPEG-H HEVC UHD HDR mandatory

Note (1): As additional legacy IRD may still be in operation in some networks like MPEG-2 SD only receivers, broadcasters will need to ensure that their broadcast will comply to their target audience.
--

NorDig transport streams composition:

- A NorDig compliant transport stream may consist of MPEG-2 SD services, MPEG-4 AVC SD services, MPEG-4 AVC HD services, MPEG-H HEVC UHD services.
- A NorDig compliant transport stream may consist of a mix of SD, HD and UHD services where technically feasible by the encoding platforms.
- As NorDig specified and certified IRD decode and display both HD and SD services there is no requirement to simulcast HD and SD versions of the same service

The supported bitstreams are listed in the table 5.1.1.

	SD		HD	UHD
NorDig IRD Profile	NorDig IRD			NorDig HEVC IRD
Codec, Profile & Level	MPEG-2 MP @ ML (max 15 Mbits/s)	MPEG-4 HP @ L.3 (max 12.5 Mbits/s)	MPEG-4 HP @ L.4 (max 20 Mbits/s)	HEVC Main10 @ L.5.1 (max 40 Mbits/s)
Resolutions	720x576 704x576 544x576 480x576 <sup>1</sup> 352x576 <sup>1</sup> 352x288 <sup>1</sup>	720x576 704x576 544x576 480x576 <sup>1</sup> 352x576 <sup>1</sup> 352x288 <sup>1</sup>	1920x1080 <sup>2</sup> 1440x1080 <sup>2</sup> 1280x1080 <sup>2</sup> 960x1080, 1280x720 960x720 640x720	3840x2160 3200x1800 2560x1440 1920x1080 1600x900 1280x720 960x540
Frame Rates	25i	25i, 25p	25i, 25p, 50p	25p, 50p
Aspect Ratio	4:3 <sup>1</sup> , 16:9	4:3 <sup>1</sup> , 16:9	16:9	16:9
Colorimetry & Transfer Function	BT.1700 Part B SDR	BT.1700 Part B SDR	BT.709 SDR	BT.709 SDR BT.2020 SDR BT.2100 HLG10 BT.2100 PQ10
Corresponding DVB Bitstream Profile(s) (see TS 101 154 Error! Reference source not found.)	25 Hz MPEG-2 SDTV	25 Hz H.264/AVC SDTV 25 Hz H.264/AVC HDTV		HEVC UHD TV, HEVC HDR UHD TV IRD using HLG10, HEVC HDR UHD TV IRD using PQ10

<sup>1</sup> Not recommended due to the varying performance receiver upscalers.  
<sup>2</sup> Limited to 25i or 25p by the constraints of H.264/AVC High Profile at Level 4.

Table 5.1: NorDig supported bitstreams.

#### Random Access Point (RAP) / Sequence header

- For H.265 HEVC, Random Access Point (RAP) requirements are defined in ETSI TS 101 154, clause 5.14.1.8 and time interval in clause 5.14.1.8.1 [26]
- For H.264 AVC, Random Access Point (RAP) requirements are defined in ETSI TS 101 154, clause 5.5.5 and time interval in clause 5.5.5.1 [26]
- For H.262/MPEG-2, Video Sequence Header requirements are defined in ETSI TS 101 154, clause 5.1.7 [26]

The NorDig Broadcaster should ensure that the maximum time interval between RAP is less than 2 secs.

#### 5.1.1 Video Decoder Reference Model

Not Applicable for RoO.

### 5.2 Supported resolutions

NorDig Broadcasters targeting NorDig IRD **shall** encode and transmit in one of the following resolutions according to ETSI TS 101 154 [26]:

- Section 5.1 “25 Hz MPEG-2 SDTV IRDs and Bitstreams”, sub-section 5.1.4 “Luminance resolution”.

- Section 5.6 “H.264/AVC SDTV IRDs and Bitstreams”, sub-section 5.6.2 “25 Hz H.264/AVC SDTV IRD and Bitstream”, sub-section 5.6.2.3 “Luminance resolution”.
- Section 5.7 “H.264/AVC HDTV IRDs and Bitstreams”, sub-section 5.7.1.4 “Luminance resolution”.

NorDig Broadcasters targeting NorDig HEVC IRD may, in addition to the above, encode and transmit in one of the following resolutions according to ETSI TS 101 154 [26]:

- Section 5.14.4 “HEVC HDR UHD TV IRDs and Bitstreams”, sub-section 5.14.4.3 “Luminance Resolutions”.
- Section 5.14.3 “HEVC UHD TV IRDs and Bitstreams”, sub-section 5.14.3.2 “Luminance resolution” with the exception of non-square pixel aspect ratios.
- Section 5.14.2 “HEVC HDTV IRDs and Bitstreams”, sub-section 5.14.2.2 “Luminance resolution” with the exception of non-square pixel aspect ratios and the exception of interlace scan.

Note: When selecting a sub-resolution, NorDig Broadcasters should consider that IRD upscaler performance may vary and should evaluate the impact of the sub-resolution on the NorDig IRD in their network.

### 5.3 Supported frame rates

NorDig Broadcasters targeting NorDig IRD **shall** encode and transmit in one of the following frame rates according to ETSI TS 101 154 **Error! Reference source not found.**:

- Section 5.1 “25 Hz MPEG-2 SDTV IRDs and Bitstreams”, sub-section 5.1.2 “Frame rate”
- Section 5.6 “H.264/AVC SDTV IRDs and Bitstreams”, sub-section 5.6.2 “25 Hz H.264/AVC SDTV IRD and Bitstream”, sub-section 5.6.2.2 “Frame rate”
- Section 5.7 “H.264/AVC HDTV IRDs and Bitstreams”, sub-section 5.7.2 “25 Hz H.264/AVC HDTV IRD and Bitstream”, sub-section 5.7.2.2 “Frame rate”

NorDig Broadcasters targeting NorDig HEVC IRD may, in addition to the above, encode and transmit in one of the following frame rates according to ETSI TS 101 154 [26]:

- Section 5.14.1 “Specifications Common to all HEVC IRDs and Bitstreams”, sub-section 5.14.1.7 “Frame rate” (1)
- Section 5.14.4 “HEVC HDR UHD TV IRDs and Bitstreams”, sub-section 5.14.4.5 “Frame Rates” (1)

NorDig Broadcasters **shall** use only 25 Hz or 50 Hz for HEVC UHD, as support for frame rates other than 25 Hz, 50 Hz is optional in the NorDig HEVC IRD.

NorDig Broadcasters **shall** only use progressive scan for HEVC encoded video as NorDig HEVC IRD are not required to support HEVC interlaced video.

Note (1): The specifications in section ETSI TS 101 154 [26] section 5.14.1.7 applies with the restrictions in ETSI TS 101 154 [26] section 5.14.4.5, i.e. only progressive scan support is mandatory for NorDig HEVC IRD.

### 5.4 Video resolution scaling Up-sampling / Up-converting

When selecting a sub-resolution, NorDig Broadcasters should consider that IRD upscaler performance may vary and should evaluate the impact of the sub-resolution on the NorDig IRD in their network.

## 5.5 Colorimetry

When transmitting BT.1700 or BT.601 SDTV video source content, a NorDig Broadcaster **shall** encode “25Hz MPEG-2 SDTV” bitstreams as defined in ETSI TS 101 154 [26], section 5.1.5.

When transmitting BT.1700 or BT.601 SDTV video source content, a NorDig Broadcaster **shall** encode “25Hz H.264/AVC SDTV” bitstreams as defined in ETSI TS 101 154 [26], section 5.6.2.1.

When transmitting BT.709 or BT.1847 HDTV video source content, a NorDig Broadcaster **shall** encode “H.264/AVC HDTV” bitstreams as defined in ETSI TS 101 154 [26], section 5.7.1.3.

When transmitting BT.2020 SDR UHD TV video source content, a NorDig Broadcaster **shall** encode “HEVC UHD TV” bitstreams as defined in ETSI TS 101 154 [26], section 5.14.3.3.

When transmitting BT.2100 HLG10 UHD TV video source content, a NorDig Broadcaster **shall** encode “HEVC HDR UHD TV Bitstreams using HLG10” as defined in ETSI TS 101 154 [26], sections 5.14.4.4.1 and 5.14.4.4.2.

When transmitting BT.2100 PQ10 UHD TV video source content, a NorDig Broadcaster **shall** encode “HEVC HDR UHD TV Bitstreams using PQ10” as defined in ETSI TS 101 154 [26], sections 5.14.4.4.1 and 5.14.4.4.3.

- If Mastering Display Colour Volume is known, a NorDig Broadcaster using “HEVC HDR UHD TV Bitstreams using PQ10” should provide the “Mastering Display Colour Volume SEI message”, as defined in ETSI TS 101 154 [26], section 5.14.4.4.3.3.2
- If Content Light Level Information is known, a NorDig Broadcaster using “HEVC HDR UHD TV Bitstreams using PQ10” should provide the “Content Light Level Information SEI message”, as defined in ETSI TS 101 154 [26], section 5.14.4.4.3.3.3

NorDig Broadcasters **shall** avoid transmitting video source content using other colorimetry standards as they are not required to be supported by NorDig IRD.

NorDig Broadcasters are not prevented from using dynamic HDR, however the NorDig IRD specification does not include any requirements for it. If dynamic HDR is delivered to the IRD, it **shall** be done in accordance with ETSI TS 101 154 [26]. The NorDig Broadcaster **shall** verify that their use of dynamic HDR does not interfere with the NorDig IRD.

NorDig Broadcasters who include dynamic HDR in the bitstream **shall** ensure that, when dynamic HDR is ignored by the NorDig IRD, the video content is of the quality expected from an HDR broadcast without dynamic HDR.

NorDig Broadcasters who want to ensure dynamic switching between SDR and HDR content is as seamless as possible by the NorDig IRD should broadcast SDR content in BT.2020, following an appropriate conversion to BT.2020 when necessary. Alternatively, NorDig Broadcasters may choose to broadcast SDR content in its original colorimetry, which may minimise bandwidth usage and avoid the need for conversion.

NorDig Broadcasters **shall** ensure that the broadcast of HDR video content compliant to ITU-R BT.2100/PQ [89] is suitable to the consumer equipment. Specifically, consumer displays typically have lower luminance and chrominance capabilities than professional reference monitors. Display adaption may be performed for example via user control of overall brightness and contrast or other types of adjustment parameters.

NorDig Broadcasters may need to convert content, so that it is suitable for consumer displays. Relevant conversion methods are described by the ITU, e.g.:

- ITU-R BT.2390 [90] “High dynamic range television for production and international programme exchange “and



- ITU-R BT.2408 [95] “Guidance for operational practices in HDR television production”

### 5.5.1 NorDig HEVC STB colorimetry

Not Applicable for RoO.

### 5.5.2 Programme production colorimetry – informative

Table 5.2 below gives the reference to the standards regarding programme production where to find appropriate chromaticity co-ordinates, opto-electronic transfer characteristics and matrix coefficients to be used for example when deriving luminance and chrominance signals from the red, green and blue primaries (or vice versa, i.e., YCbCr to RGB):

Active composition resolution in the “Decoder Composition Output” (equal to the production resolution) (Horizontal x Vertical)	Standards regarding programme production colour parameters	Comments
720x576	ITU-R BT.1700 [85] (replaces ITU-R BT.470 System B, G) and ITU-R BT.601 [83]	Note that 576 lines in both interlaced scan (576i) and progressive scan (576p) <b>shall</b> be processed and output with equal colour parameters.  Standard Dynamic Range production parameters.
1280x720	ITU-R BT.1847 [86] (SMPTE 296M)	The colour parameters in SMPTE 296M are the same as in ITU-R BT.709 [84].  Standard Dynamic Range production parameters.
1920x1080	ITU-R BT.709 [84] (SMPTE 274M)	The colour parameters in SMPTE 274M are the same as in ITU-R BT.709 [84].  Standard Dynamic Range production parameters.
3840x2160	ITU-R BT.2020 [88]	Standard Dynamic Range production parameters.
3840x2160	ITU-R BT.2100 [89]	High Dynamic Range production parameters used for PQ10 and HLG10 by DVB (1).

Table 5.2: Reference to the standards regarding programme production.

Note (1): In ITU-R BT.2100 [89] table 9 “Digital 10- and 12-bit integer representation”, both “Narrow range” and “Full range” are defined. DVB is however only specifying the use of 10-bit “Narrow range” in its TS 101 154 [26].

## 5.6 Dynamic changes in the video stream

The NorDig Broadcaster may use dynamic changes of either the video codec or the video format.

The NorDig Broadcaster should minimise the frequency of dynamic video changes as IRD may take up to five seconds to resume output of valid video after each dynamic change.

The NorDig Broadcaster should perform dynamic video changes at programme boundaries, to minimise the disruptions to IRD video output caused by such changes.

The NorDig Broadcaster **shall** ensure that dynamic changes between video formats and/or frame rates occur at a Random Access Point (or Video Sequence Header followed by an I-frame for H.262 MPEG-2).

### 5.7 **MPEG-2 Minimum video bandwidth**

NorDig Broadcasters may encode MPEG-2 video down to 1.0Mbps for video resolutions up to full Standard Definition resolution video (720x576). Any lower bitrate might not be supported by NorDig IRDs.

### 5.8 **Frame Cropping**

The NorDig Broadcaster **may** provide frame cropping signalling for video encoded with 1088 lines, for 1080 lines formats. If frame cropping is signalled, the NorDig IRD will use this to decide which 8 lines to hide in the Decoder Composition Output or else it will hide the bottom 8 lines.

Frame cropping signalling should conform to:

- H.265 HEVC: ETSI TS 101 154 [26] section 5.14.1, sub-sections 5.14.1.3
- H.264 AVC: ETSI TS 101 154 [26] section 5.7.1, sub-sections 5.7.1.2

### 5.9 **Overscan**

A NorDig Broadcaster wishing to signal to the NorDig IRD and NorDig HEVC IRD to apply overscan or to display the complete broadcast video image on services carrying H.264 AVC video should use the *overscan\_info\_present\_flag* and *overscan\_appropriate\_flag* defined in ITU-T H.264, Annex E.2.1.

A NorDig Broadcaster wishing to signal to the NorDig HEVC IRD to apply overscan or to display the complete broadcast video image on services carrying H.265 HEVC video should use the *overscan\_info\_present\_flag* and *overscan\_appropriate\_flag* defined in ITU-T H.265, Annex E.2.1 and ETSI TS 101 154 [26], section 5.14.1, sub-sections 5.14.1.5.0 and 5.14.1.5.1.

The NorDig Broadcaster **shall** ensure the flags, if used, are encoded according to Table 5.3.

<b>overscan_info_present_flag</b>	<b>Overscan_appropriate_flag</b>	<b>Usage</b>
0x0 or not broadcasted	n/a	No preferred display method
0x1	0x0	Important information in entire video frame
0x1	0x1	Decoded picture suitable for applied overscan

Table 5.3: Broadcast overscan flag.

#### 5.9.1 **Safe area for overscan**

The NorDig Broadcaster **shall** ensure that they follow the safe areas recommendations in EBU R 95 [71].

### 5.10 **Video Output and Display**

No RoO specification.

5.11 ***Restrictions on analogue video output***

No RoO specification.

5.12 ***Display of 4:3 aspect ratio content***

No RoO specification.

5.13 ***Rescaling for HbbTV application***

No RoO specification.

5.14 ***Graphic compositing with HDR video - informative***

No RoO specification.

## 6 Audio

### 6.1 General

This section includes several aspects regarding the set-up up of audio parameters within broadcast television and radio services, such as:

- The quality of audio at different encoding bit rates and indications for the selection of appropriate bitrate for different audio quality.
- A brief note regarding subjective test method for audio quality.
- A recommended set-up of audio parameters at the encoding headend.
- Recommendations regarding the handling of multichannel audio in the production, encoding and decoding domains.
- Commentary to assist the understanding of employing the correct audio metadata for loudness and down-mixing.
- Detail regarding the coding artefacts of audio which may occur when re-encoding audio for onward distribution.

#### 6.1.1 Methode of subjective audio quality assessment

When encoding linear PCM audio into compressed audio, employing standard encoding schemes artefacts may be added to the original audio. These encoding artefacts may be audible to normal human hearing, to evaluate the effect of these artefacts there are several methods employed to subjectively assess the fidelity of the decoded audio when compared to the original baseband PCM audio. The resulting figures obtained by these methods indicate the subjective qualities of the audio encoding and decoding process.

#### ITU-R BS.1116 and BS.1284

One of the primary methods employed in subjective audio quality assessment is International Telecommunication Union Recommendation BS.1116-3. This method is primarily intended for the evaluation of audio content where the audio artefacts is judged to be minor or slightly impaired and are set out below in Table 6.1.

There is also the closely related International Telecommunication Union Recommendation BS.1284-1 which is intended for listening tests that are not as stringent as BS.1116-1, and the grading scales are accompanied with a perceived description.

Impairment	Grade	Quality (only in ITU-R BS.1284-1)
Imperceptible	5.0	5 Excellent
Perceptible, but not annoying	4.0	4 Good
Slightly annoying	3.0	3 Fair
Annoying	2.0	2 Poor
Very annoying	1.0	1 Bad

Table 6.1: Grading scale employed by ITU-R BS.1116-1 (originally ITU-R BS.1284-1).

The methodology employed in the subjective listening process is based on the ABX method, in this method, the listener is presented with three audio excerpt signals in sequence. Excerpt A is always the reference signal, excerpt B is a secondary reference and excerpt X is the excerpt under evaluation. The listener then has to decide if X sounds the same as either A or B and grade the audio quality of X according to the grading scale.

Typically, therefore signal A may be uncompressed baseband audio, signal B may be of poor or over compressed quality and signal X a proposed sampling and encoding bitrate to be assessed prior to use.

### ITU-R BS.1534 (MUSHRA)

Another method employed in more recent subjective quality assessments is International Telecommunication Union Recommendation BS.1534-3. This method mirrors many aspects of Recommendation ITU-R BS.1116 and uses the same grading scale as is used for the evaluation of picture quality (i.e. Recommendation ITU-R BT.500). This method called “Multi Stimulus test with Hidden Reference and Anchor (MUSHRA)” is suitable for evaluation of intermediate audio quality and gives accurate and reliable results.

In the MUSHRA test method, the subject can switch at will between the reference signal and any of the systems under test, typically using a computer-controlled replay system. The subject is presented with a sequence of trials. In each trial the subject is presented with the reference version, the low and mid anchor, as well as all versions of the test signal processed by the systems under test. For example, if a test contains 8 audio systems, then the subject is allowed to switch near instantaneously between the 11 test signals and the open reference (1 reference + 8 test systems + 1 hidden reference + 1 hidden low anchor + 1 hidden mid anchor).

The assessors are required to score the stimuli according to the continuous quality scale (CQS). The CQS consists of identical graphical scales which are divided into five equal intervals with the adjectives as given in Fig. 6.1 from top to bottom.

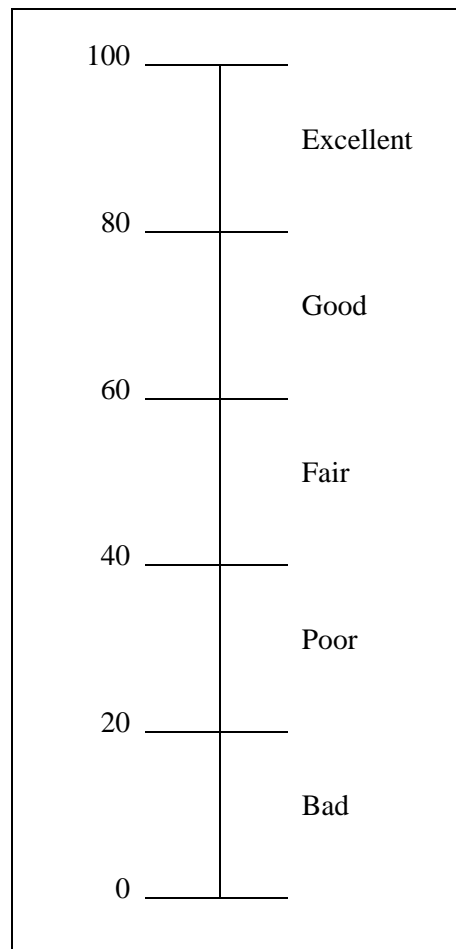

Figure 6.1: Grading scale employed by ITU-R BS.1534.

In the MUSHRA test method, a high-quality reference signal is used and the systems under test are expected to introduce significant impairments. MUSHRA is to be used for assessment of intermediate quality audio systems. If MUSHRA is used with appropriate content, it is ideal that listener scores should range between 20 - 80 MUSHRA points. If scores for the majority of test conditions fall in the range of 80 - 100 it may be true that the results of the test are invalid.

Compared to Recommendation ITU-R BS.1116, the MUSHRA method has the advantage of displaying many stimuli at the same time so that the subject is able to carry out any comparison between them directly.

### **Recommended practices for evaluation design**

Significant effort has to be made to ensure that the audio content employed for the evaluation of encoder and decoder chains is relevant and sensitive. Typical audio content that has historically been employed are certain specific music and speech excerpts along with that of audience applause, it is also important and necessary to include audio content that has been recorded with different microphone set-up techniques and/or the use of special audio imagery.

With the increasing use of modern low bit rate encoder's audio content which intrinsically employs material that is based around high frequencies is of particular interest within the evaluation process. Encoder buffer clearance rates may also be revealed by the use of audio content with repeated transients which occur at higher frequency rates.

Within the evaluation process is the employment of expert listeners or so called "golden ears" rather than amateur or inexpert listeners is required, research has found that the results obtained from inexpert listeners may be skewed and show much larger differences among the answers than those obtained from expert listeners. *Viz.* inexpert listeners do not know what to listen for and therefore tend to allocate higher points than expert listeners do; inexpert listeners do not appear to hear as much difference between audio content excerpts as the expert listeners can and therefore cannot differentiate with the same ease and confidence.

### 6.1.2 Audio terminology

The term "Normal" within this specification refers to audio streams that are:

- Intended for the majority of users or users that are not interested in any supplementary audio, and
- audio signalled in the supplementary descriptor as `mix_type '1'` and editorial description '0' and in the ISO 639 language descriptor with audio type 'Undefined' and language not set to 'nar' (1).

A Supplementary Audio (SA) service may be either (2):

- Audio Description (AD): audio that includes narration describing the action of the scene and is targeted at users with visual or cognitive impairments.
- Spoken subtitling (SS): audio that includes a spoken rendition of the broadcasted subtitle and is targeted at users with visual or cognitive impairments.
- Dialogue Enhancement (DE): functionality that provides improved speech intelligibility. It is targeted at users with hearing impairments but can also serve as improvement for listening in noisy environments.

NGA Audio service (NGA):

- The NGA Audio services support delivery of audio content from mono, stereo, and 5.1 channel-based audio sources, as well as Immersive Audio from Channel-based, Object-based or Scene-based audio sources. Additionally, NGA systems efficiently offer services such as multi-language support, accessibility services, personalization and interactivity.

#### NGA Accessibility Services:

- Accessibility services in the context of an NGA Audio service are Audio Description, Spoken Subtitles and Dialogue Enhancement as described above.

#### NGA Preselections:

- NGA Preselections: alternative audio versions are made available to the user for 'User Personalization'. The NGA Preselections can share some of the Audio Elements contained within a single NGA stream, as these are combined in the receiver to create the final audio mix.

#### Stereo Audio:

- Stereo audio is defined as an audio stream with two channels of audio with loudspeakers positioned left and right of the center of the screen.

#### Multichannel Audio, Immersive Audio:

- Multichannel audio is defined as an audio stream with more than two channels of audio with all loudspeaker positions in one plane. Audio streams that contain more than 5.1 audio channels or exceed the horizontal plane are considered Immersive Audio.

Note 1: only applicable to non-NGA services

Note 2: Supplementary Audio (SA) streams are not used in the context of NGA services. Instead, NGA Accessibility Services (Audio Description, Spoken Subtitles and Dialogue Enhancement) are integrated features within NGA streams and can't be handled externally as SA streams.

### 6.1.3 Internal Reference Level

Within NorDig the level for reference or lineup tone for transmission shall be -18 dB FS below clipping level, in accordance with EBU Recommendation R.68 [74] "Alignment level in digital audio production equipment and in digital recorders" as recommended by ETSI TS 101 154 [26].

Note: The alignment level for sound-programme exchange does not need to be changed with the introduction of loudness normalization.

### 6.1.4 Loudness levels

To achieve loudness and dynamic range consistency over stream types (= audio codecs), the operator shall follow the following guidelines on audio leveling and dynamic range control settings.

Measuring programme loudness shall be accomplished using a loudness meter compliant with ITU-R BS.1770-4 [76] and EBU R 128 [72]. Those meters provide a loudness reading in units of LUFS (= "Loudness Units relative to Full Scale").

It is strongly recommended to use the loudness levels defined in EBU Tech 3343 and EBU Tech 3344 [73]. In general, it should be assumed that each content provider that supplies programs content to the platform head-end will follow the rules set in EBU Tech 3344. These guidelines state that program loudness for each program should be -23 LUFS.

A television service may consist of a sequence of programming content in successive order, including commercials and interstitials and all are interpreted as individual programming. The overall long-term integrated loudness for a complete service is therefore also meant to equate to -23 LUFS (service loudness).

Since according to section 5.1.3, the alignment level is specified to be at -18 dBFS (1 kHz tone), loudness meters will read it as **-18 LUFS** with the absolute scale (or +5 LU on the relative EBU-mode scale),

provided that the 1 kHz tone is present (in phase) on both the left and right channel of a stereo or surround sound signal. If the 1 kHz tone of  $-18$  dBFS is used only in a single front channel, the loudness meter will read  $-21$  LUFS (or  $+2$  LU on the relative scale).

According to EBU R 128 [72], the permitted Maximum True Peak Level measured according to ITU-R BS.1770 [76] shall not exceed  $-1$  dBFS in linear production environments. For broadcast applications using stream types (=audio codecs) at reasonable bitrates, the recommended Maximum Permitted True Peak Level should be restricted to  $-2$  dBTP. Relatively low bitrates might require even decreased limits for the Maximum True Peak Level.

Note: This recommendation obsoletes the “Maximum Permitted Level (PML)” of  $-9$  dBFS in ITU-R BS.645.

In order for this to successfully work as intended all the way to the domestic receiver, the audio level itself must be under control, but also, it is of utmost importance that the audio metadata for loudness carries the correct values. To accommodate for the specific properties of the different stream types (=audio codecs), the rules given in the associated audio encoding sections (in section 6.3) shall apply.

Caveat: Only set static values when the content provider does not supply loudness metadata. Some content providers may supply dynamically changing loudness metadata.

Occasionally, the platform head-end may take their own loudness measurements in order to verify that each content provider has aligned the loudness levels in a correct way according to EBU Tech 3344 [73] and is legal. Additional information on handling on audio loudness can be found in EBU tech 3344 [73].

## 6.2 **Supplementary Audio Services**

A supplementary audio service (as defined in ETSI TS 101 154 [26]) is specified below for the “in-service delivery” and applies when “normal” audio streams and the supplementary audio streams are available within the same service (i.e. listed within same PMT).

### **A Supplementary Audio (SA) service may be broadcasted as either:**

- “Broadcast mixed”: pre-mixed audio by the broadcaster where the Supplementary Audio stream is a complete self-standing audio which contains both the programme audio mixed together with the supplementary audio content.
- “Receiver mixed”: audio containing only the supplementary audio content which is not a complete self-standing audio and is not intended to be presented on its own. The receiver mixed supplementary audio and programme audio are typically mixed together in the IRD, under some control of the broadcaster via broadcast of supplementary data.

#### 6.2.1 Implementation of Supplementary Audio

Within NorDig, the most common way of using Supplementary Audio is to use the facility to broadcast spoken subtitles, audio description as broadcast mix is also in use as a Supplementary Audio service. Since audio dubbing of content is very rarely employed within NorDig, the original spoken audio language content is broadcasted together with subtitling and an accompanying supplementary audio track which may either be i) a spoken version of the subtitle or ii) an original language version track with narrative description (in the same language) . The viewer is then at liberty to select their preference accordingly dependent upon their personal preference or needs.

Within NorDig, there are several different methods employed to broadcast Supplementary Audio for the viewer. In general, the following methods are employed:

- Broadcast mixed, Supplementary Audio signalled within the main service (in use in Sweden).
- Broadcast mixed, a separate TV service (in use in Denmark and Norway).
- Receiver mixed without metadata; Supplementary Audio signalled.



- Receiver mixed with metadata; Supplementary Audio signalled.
- Supplementary Audio only, on a separate TV service (no longer used in NorDig networks).
- Supplementary Audio only with video, on separate TV service.
- Broadcast mix Audio Descriptive service with a narrative voice that describes the scene portrayed during natural gaps in dialogue, allowing viewers with visual impairment to follow on screen action. This functionality is presented to the viewer as an alternate language track and selected by the viewer via the language/audio function on the remote control. (This format is in use in Ireland, Sweden, Norway & Denmark).

When Supplementary Audio is signalled via SI within the DVB stream, the user may configure the IRD to use “Audio Description ON/Yes” in the set-up menu to select the supplementary audio track.

The broadcaster sources the appropriate type of supplementary audio, (broadcast mixed or receiver mixed). The standard method of broadcasting receiver mixed audio is together with metadata instruction to “duck” or reduce the audio level of the main programme stream during periods of descriptive narrative, this metadata is typically carried within a supplementary audio stream and follows operational practice set out BBC WHP 198 [104].

The alternate method for the broadcaster in supplying supplementary audio is to employ “broadcast mixed” supplementary audio.

In some NorDig countries a separate duplicate TV service is employed for the supplementary audio, with only the audio track differing in content from that of the “main” service.

This can simplify selection of the accessibility service for the viewer; however, it is an inefficient use of bandwidth and can complicate service selection.

Note: Supplementary Audio (SA) streams are not used in the context of NGA services. Instead, NGA Accessibility Services (Audio Description, Spoken Subtitles and Dialogue Enhancement) are integrated features within NGA streams and can't be handled externally as SA streams.
--

### 6.2.2 Spoken Subtitle receiver-mixed supplementary audio: ducking

The receiver mixing between supplementary audio and normal audio can be done in various ways.

Generally, when the supplementary audio is active, the normal audio is attenuated or “ducked”. When supplementary audio is inactive, the normal audio returns to its original level.

The timing, attenuation speed, release speed, attenuation level, and delay of the supplementary audio in relation to when the subtitle is presented on screen, can be adjusted at the play-out chain. It is generally deemed preferable for the viewer if the normal audio that is not reduced too much but also maintains a good speech intelligibility of the spoken subtitle. The attenuation of the normal audio with the range of -6 to -12 dB is considered to adequate in order to achieve this. Too fast a change of normal audio level might give the impression of “pumping” audio and is undesirable.

It has been found through subjective observation that some slight delay of the spoken subtitles compared to when the subtitle is displayed on screen can be advantageous to the eye and assist comprehension.

Example:

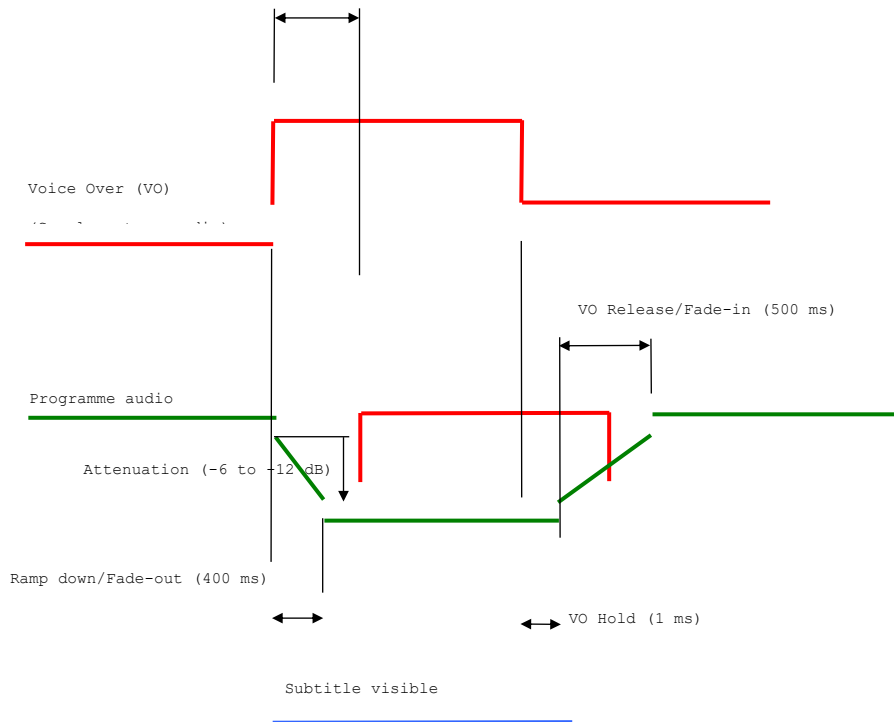

Figure 6.2: Spoken Subtitle supplementary audio.

### 6.3 Audio Encoding

NorDig has defined four audio encoding formats:

- **MPEG-1 Layer II**, which refers to MPEG-1 Layer II up to stereo (2.0) channel encoding.
- **E-AC-3**, which refers to E-AC-3 streams (including **AC-3**) up to 5.1 multi-channel encoding
- **HE-AAC**, which refers to MPEG-4 HE AAC Level 4 (including AAC-LC) up to 5.1 multi-channel encoding.
- **AC-4**, which refers to AC-4 as defined in ETSI TS 103 190-2 [98] for multi-channel, immersive and personalised audio.

Note: Some NorDig broadcasters have aligned the delivery of their MPEG-4 based services to include HE-AAC, E-AC-3 or AC3 stream types only, this is optional within NorDig and MPEG 4 services may legally be transmitted with MPEG-1 Layer II encoding format.

HEVC services shall always use NGA, i.e. AC-4 audio. To serve legacy HEVC IRDs without support for NGA, legacy stream types (e.g. MPEG-1 Layer II, HE-AAC, AC-3, E-AC-3) may be broadcasted in addition to NGA.

#### 6.3.1 Summary NorDig IRD “Profiles” (variants and capabilities) – Audio Decoding (informative)

Audio decoders comply with the DVB Implementation Guidelines for the use of MPEG-2 Systems, Video and Audio in satellite, cable and terrestrial Broadcasting Applications ETSI TS 101 154 [26].

Within the NorDig network, where there is no single operator responsible for the acceptance of the Integrated Receiver Decoder, the NorDig Basic IRD supports as a minimum:

- MPEG-1 Layer II
- E-AC-3 (AC-3)

- HE-AAC.

Within the NorDig network, where there is a single operator or regulator responsible for specifying and accepting the functionality of the IRD and for ensuring that the minimum requirements are met. The operator or regulator may specify one of following minimum audio decoding format alternatives for the NorDig Basic IRD to support (as a minimum) for that specific network:

- MPEG-1 Layer II, E-AC-3 and HE-AAC audio decoding, or
- MPEG-1 Layer II, E-AC-3 audio decoding, or
- MPEG-1 Layer II, HE-AAC audio decoding.

NorDig HEVC IRD launched after 1<sup>st</sup> of July 2020 additionally supports AC-4 audio decoding, for all other NorDig IRDs, AC-4 decoding is optional.

NorDig HbbTV IRDs launched after 1<sup>st</sup> of July 2020 support at least all mandatory features and requirements of HbbTV v2.0.2 (ETSI TS 102 796, v.1.5.1 [27]). Support for HbbTV is optional with NorDig Basic IRDs and for STBs according to the NorDig HEVC profile, but it's mandatory for iDTVs according to the Nordig HEVC profile.

Note: As NorDig HEVC IRDs have to support E-AC-3 and AC-4, the conditional requirement from HbbTV v2.0.2 is fulfilled and all Nordig HEVC IRD also have to support these audio codecs from broadband delivery.

**The following audio modes may be employed in the NorDig region.**

### 6.3.2 MPEG-1 Layer II

It shall be encoded according to ISO 11172-3 **Error! Reference source not found.** and constrained according to ETSI TS 101 154 [26], section 6.1.

For MPEG-1 Layer II audio input, broadcasters shall ensure that MPEG-1 Layer II audio stream has an equivalent loudness level of -23 LUFS, as this is assumed by NorDig IRDs.

#### **MPEG-1 Layer II: Recommendations / Requirements on Audio Handling**

The following MPEG-1 Layer II modes may be employed:

Monoaural, Joint Stereo, Stereo

Joint Stereo mode should be used with care only. At bitrate up to 160 kbps, it can increase encoding efficiency. At 192 kbps and above it usually better to use the stereo mode.

The following sampling frequencies may be employed:

48 kHz, 44.1 kHz, 32 kHz

The recommended sampling frequency is 48 kHz.

The following bit rates for coded audio may be employed:

64 kbit/s, 96 kbit/s, 128 kbit/s, 160 kbit/s, 192 kbit/s,  
224 kbit/s, 256 kbit/s, 320 kbit/s, 384 kbit/s.

Recommended Audio Bitrates for good to excellent audio quality:

	Mono	Stereo
MPEG-1 Layer II	96 – 128 kbps	192 - 256 kbps

Table 6.2.

For MPEG-1 Layer II, it is recommended to use constant bit rate for the audio encoding for a format (mono or stereo), unless the network/operator is sure that all IRDs on the market support variable bit rate

for these audio codecs. When changing audio format (between mono and stereo) it is often acceptable to change bit rate.

### 6.3.3 E-AC-3 and AC-3

It shall be encoded according to ETSI TS 102 366 [33] and constrained according to ETSI TS 101 154 [26] section 6.2.

AC-3 and E-AC-3 encoders shall employ a sampling frequency of 48 kHz.

E-AC-3 and AC-3 is based on a constant bitrate (CBR) encoding scheme.

Recommended Audio Bitrates for good to excellent audio quality:

	Stereo		Multichannel 5.1	
	Good	Excellent	Good	Excellent
AC-3		256 kbps	384 kbps	448 kbps
E-AC-3		192 kbps	256 kbps	448 kbps

Table 6.3.

For AC-3, it is recommended to use constant bit rate for the audio encoding for a format (mono, stereo or multi-channel), unless the network/operator is sure that all IRDs on the market support variable bit rate for this audio codec. For E-AC-3 NorDig IRDs should theoretically support variable bit rate but should be used with care. When changing audio format (between for example stereo and multi-channel) it is often acceptable to change bit rate.

#### AC-3 and E-AC-3 metadata

With AC-3 and E-AC-3, the loudness reference level is transmitted in the bitstream's parameter called dialnorm. The value of this data field shall represent the measured loudness in LUFS according to ITU-R BS.1770-4 [76] and EBU R 128[72].

Dynamic Range Compression gain values are generated by the encoder based on the compression profile selected by the broadcaster or encoder operator. (1)

Downmix gains can be configured by the broadcaster or encoder operator.

Note 1: When AC-3 or E-AC-3 encoders are not fed with metadata, they will always add default metadata.

Note 2: In addition to the compression profile, the encoder takes care that DRC gains are suitable to prevent clipping in the audio decoder when audio has to be reproduced at a higher output level than encoded or when a multichannel audio representation has to be down-mixed.

#### Typical "Dolby" Audio Metadata Parameters

The table below describes typical values for "Dolby" audio metadata that are often used and can be of help for a broadcaster to configure an audio encoder.

Metadata Parameter	Professional	Consumer	Typical Value	Comment
Program Configuration	X		---	Mostly for Dolby E
Program Description Text	X		---	Could be language, etc.
Dialogue Level		X	<b>-23</b>	Recommended value for loudness alignment to EBU R 128 productions
Channel Mode		X	<b>3/2 or 2/0</b>	Alternates depending on content. "X/Y" where X is the number of front channels and Y is the number of surround channels
LFE Channel		X	<b>Enabled</b>	Typically enabled for 5.1 (needs three or more channels to be enabled)
Bitstream Mode		X	<b>Complete Main</b>	
Line Mode Compression		X	<b>Music Light</b>	Suits most content types.
RF Mode Compression		X	<b>Music Light</b>	Suits most content types.
RF Overmodulation Protection		X	<b>Disabled</b>	Should normally be disabled
Center Downmix Level		X	<b>0.707</b> <b>(-3 dB)</b>	de facto commonly used for 5.1 content
Surround Downmix Level		X	<b>0.707</b> <b>(-3 dB)</b>	de facto commonly used for 5.1 content
Dolby Surround Mode		X	<b>Not Indicated</b>	Helps to not change user selected setting in consumers' Dolby Surround decoders
Audio Production Information		X	<b>No</b>	
Mix Level		X	---	
Room Type		X	<b>Not Indicated</b>	
Copyright Bit		X	<b>No</b>	
Original Bitstream		X	<b>No</b>	
Preferred Stereo Downmix		X	<b>Lo/Ro Preferred</b>	Useful for music material. Most consumer decoders overrides to Lt/Rt downmix anyway.
Lt/Rt Center Downmix Level (Extended BSI)		X	<b>0.707</b> <b>(-3 dB)</b>	de facto commonly used for 5.1 content
Lt/Rt Surround Downmix Level (Extended BSI)		X	<b>0.707</b> <b>(-3 dB)</b>	de facto commonly used for 5.1 content
Lo/Ro Center Downmix Level (Extended BSI)		X	<b>0.707</b> <b>(-3 dB)</b>	de facto commonly used for 5.1 content
Lo/Ro Surround Downmix Level (Extended BSI)		X	<b>0.707</b> <b>(-3 dB)</b>	de facto commonly used for 5.1 content

Dolby Surround EX Mode		X	<b>Not Indicated</b>	Helps to not change user selected setting in consumers' home cinema decoders
A/D Converter Type		X	<b>Standard</b>	
DC Filter	X		<b>Enabled</b>	Could be disabled only if you are sure that there is no DC in the signal
Lowpass Filter	X		<b>Enabled</b>	Prevents aliasing
LFE Lowpass Filter	X		<b>Enabled</b>	Should only be disabled if the LFE signal has no signal above 120 Hz
Surround 3 dB Attenuation	X		<b>Disabled</b>	TV sound is normally produced in mixing rooms with all five channels at the same sound pressure level
Surround Phase Shift	X		<b>Disabled</b>	Enabled can disturb 5.1 listening to music productions.

Table 6.4.

**Professional:** These parameters are either carried in a Dolby E bitstream or often statically set in the AC-3, E-AC-3, or AC-4 encoder.

**Consumer:** The consumer's AC-3, E-AC-3 or AC-4 decoder uses these parameters to create the best possible audio program possible on each consumers playback system, ranging from a small TV set with built-in loudspeakers or a complete home cinema surround sound system.

The metadata parameters above are typically used by a broadcaster also for HE-AAC/LC-AAC encoding but are normally handled and converted into to similar parameters inside that encoder.

It is quite normal to use two or more sets of standardized metadata sets for different types of content such as "stereo", "5.1 multichannel", "film/drama", "news", etcetera, but can of course be set specifically for each program.

Further details on AC-3 and E-AC-3 metadata are described in "Dolby Metadata Guide" **Error!**

**Reference source not found..**

#### 6.3.4 MPEG 4 HE AAC

It shall be encoded as described in ISO 14496-3 **Error! Reference source not found.** and constrained according to ETSI TS 101 154 [26] sections 6.4, 6.5 and Annex C.5.

The following channel mode may be employed with MPEG-4 HE AAC:

Mono, stereo, multi-channel up to 5.1

Encoders compliant to the MPEG-4 HE AAC family shall employ a sampling frequency of 48 kHz.

MPEG-4 audio bitstreams shall comply to either of the following profiles:

- AAC Profile
- High Efficiency AAC profile

The recommended Profile to use is the High Efficiency AAC Profile.

For each of these profiles, bitstreams shall not exceed Level 4 restrictions. In case of the High Efficiency AAC Profile, the downsampled SBR mode shall not be utilized, i.e. the sampling frequency of the AAC-LC Core shall be restricted to 24 kHz.

*Informative note:*

*The AAC Profile is a subset of the High Efficiency AAC Profile. The AAC Profile utilizes the AAC-LC (AAC low complexity) coding tool only, while the HE AAC profile adds the SBR (spectral bandwidth replication) tool to enhance the coding efficiency by a parametric representation of the high frequency bands. For 2-channel stereo emissions the coding efficiency is further increased by utilizing the PS (parametric stereo) tool as available with the High Efficiency AAC v2 profile.*

*Within all profiles, level 2 restrictions allow for 2 channel stereo transmissions, while level 4 constraints additionally permit for multi-channel up to 5.1 audio.*

*Support for the High Efficiency AAC v2 profile is not mandated by the NorDig IRD specification. Therefore 2-channel stereophonic reproduction from streams utilizing the parametric stereo tool may not be supported by all IRDs. Unless it is guaranteed that all IRDs used in the network support it, the usage of the parametric stereo tool should be avoided.*

MPEG-4 audio bitstreams shall be encapsulated in the LATM/LOAS bitstream format.

The MPEG-4 AAC and HE-AAC codecs does not require fixed bitrate levels (as MPEG-1 Layer II); bitrate figures below are approximations only (several MPEG TV Encoders on market often re-use bitrate levels from MPEG-1 Layer II into MPEG-4 AAC bitrate settings).

Recommended Audio Bitrates for good to excellent audio quality:

	Mono	Stereo		Multichannel 5.1	
	Good	Good	Excellent	Good	Excellent
AAC Profile	64 kbps	128 kbps	160 - 192 kbps	256 kbps	320 kbps
High Efficiency AAC Profile	32 kbps	(64) – 96 kpbs	---	(160) - 192 kbps	---

Table 6.5.

Note: NorDig has the intention to specify slightly different bitrates for Normal audio and supplementary audio streams in the future in the NorDig Rules of Operation.

Note: Operators may want to pay attention to possible high peak bitrates even in constant bitrate mode: The MPEG-4 specification requires a minimum buffer size of 6144 bits per audio channel per frame. Given the “AAC profile” (aka “AAC low complexity”) with its frame size of 1024 samples, this equals to 6 bits per audio sample.

### MPEG-4 AAC metadata

The MPEG-4 HE AAC audio stream should contain appropriate metadata to control the loudness, the dynamic range and (if applicable) the downmixing process in the decoder:

- *program\_reference\_level*: The value of this parameter, if present, shall match the value of the measured audio loudness in LUFS according to EBU R128 [72] (see section 6.1.4). If this parameter is not present, broadcasters shall ensure that the audio stream has an equivalent loudness level of -23 LUFS.
- *dyn\_rng\_ctl* and *dyn\_rng\_sgn*: These two data fields specify the “light compression” gain factors.
- *compression\_value*: This data field specifies the “heavy compression” gain factor.
- *matrix\_mixdown\_idx* or preferably *center\_mix\_level* and *surround\_mix\_level*: gain factors to control the mixdown process

- *drc\_presentation\_mode*: This value specifies which DRC processing scheme (light or heavy compression) the decoder has to apply in the downmixing process to prevent any overloads. For use in the Nordig region, this value shall be set to “mode 1”.

The encoded bitstreams shall have either sufficient headroom and/or dynamic range control values as specified by the *drc\_presentation\_mode* to prevent any overload when IRDs perform downmixing.

The requirements for *drc\_presentation\_mode\_1* imply that (considering the worst case scenario):

- Both dynamic range control data (*dyn\_rng\_ctl/dyn\_rng\_sgn* and *compression\_value*) shall be transmitted.
- DRC gains values in *dyn\_rng\_ctl/dyn\_rng\_sgn*, when applied in the decoder without scaling, it shall avoid any highly undesired overload for levelling towards a target level of -31 dB and downmixing to a stereo representation.
- DRC gains values in *compression\_value*, when applied in the decoder, it shall avoid any highly undesired overload for levelling towards a target level of -23 dB and downmixing to a mono representation.

If no metadata are present in the transmitted audio stream, the NorDig IRD assumes the following default values:

- *Program\_reference\_level*: -23 dBFS
- No DRC gains for both light and heavy compression
- Downmix gains -3dB for both center and surround channels (if applicable by channel mode)
- *Drc\_presentation\_mode*: Mode 1 (use heavy compression for downmixes from 5.1 to stereo)

### 6.3.5 AC-4

#### General information

AC-4 as specified in ETSI TS 103 190-2 [98] is the only NGA codec selected for the use in NorDig and support therefore is mandatory for all NorDig HEVC IRDs launched after 1<sup>st</sup> of July 2020.

AC-4 offers the possibility to carry many different components in one stream, and to combine these components into complete experiences in the IRD. Therefore, receiver mixing capabilities are fundamental to every AC-4 decoder.

The AC-4 elementary streams each carry a table of contents (TOC) which lists the different experiences (called presentations) that can be derived.

In the context of AC-4, Audio Preselections are implemented as AC-4 presentations, and Audio Programme Components are implemented by substream groups.

AC-4 presentations aggregate substream groups. In a presentation, substream groups take on a specific role (such as M&E, dialogue, accessibility, etc.). Substream groups, in turn, are aggregations of substreams.

It is important to note that there is a many-to-many relationship between these concepts. This provides flexibility to reuse substream groups and substreams many times over.

Further details on AC-4 audio are informatively described in Annex C.

#### Encoding constraints

AC-4 audio streams shall be encoded according to ETSI TS 103 190-2 [98] and shall be constrained



according to TS 101 154 [26], clause 6.7. This implies that the `bitstream_version` field shall be set to the value 2 and the `presentation_version` field shall be set to the value 1. Additionally, AC-4 audio streams shall contain at least one “Normal Audio” presentation, which `md_compat` field is less than or equal to three. The number of presentations in an AC-4 audio stream shall be 64 or less.

AC-4 should be encoded using the average bitrate (ABR) encoding scheme. This encoding mode meets the requirements of the buffer models used by the constant bitrate (CBR) transmission channel of the MPEG-2 Transport Stream while it also preserves the audio quality under all characteristics of the encoded audio signal.

The raw AC-4 frames shall be encapsulated in the AC-4 Sync Frame format.

AC-4 encoder shall employ a sampling frequency of 48 kHz.

Recommended Audio Bitrates for good to excellent audio quality:

Stereo	Multichannel 5.1	NGA Immersive 5.1.4	NGA Immersive 7.1.4 plus 4 objects	Dialogue or Accessibility tracks (mono)
48 - 64 kbit/s (Good- Excellent)	96 - 144 kbit/s	192 - 288 kbit/s	320 - 512 kbit/s	32 - 48 kbit/s

Table 6.6.

AC-4 NorDig IRDs support variable bit rate. It is recommended to use the encoder in average bit rate mode which produces streams that adhere to the AC-4 buffer model.

Note: In average bitrate mode (ABR), the maximum frame size is limited to 3,072,000bits/s divided by the frame rate in fps and does not exceed 16,384 bytes.

AC-4 audio streams should be encoded at the same frame rate as the accompanying video stream. I-frames should be generated at the same interval and position corresponding to their decoding time stamp.

In case of HFR video, ideally the base frame rates are used that correspond to the video frame rates, i.e. video to audio frame rates result in an integer fraction. If higher audio frame rates are required for flexible segmenting of the audio stream, then the “efficient high frame rate” (EHFR) mode should be used.

### Multiple Presentations

If the AC-4 elementary stream contains more than one presentation, the following rules shall apply:

- Each presentation shall contain a unique `presentation_id`
- The presentations shall be sorted in the AC-4 TOC in order of their preference
- The `presentation_ids` shall be in ascending order

Within one language, there shall be the default main only presentation first before all other presentations with the same language. If there are one or more presentations with audio description and spoken subtitles and one or more presentations with audio description only for the same language, then the default presentation with audio description and spoken subtitles shall precede the default presentation with audio description only.

Presentations in the elementary stream can be grouped either by language (i.e. first all presentations with language A, then all presentations with language B, a.s.o.) or by type (i.e. first all complete main only presentations, followed by all presentations with audio description, a.s.o.).

Presentations with the default language shall be listed before presentations with other languages of the same type.

If there are more than one presentation of the same language and audio type in the stream, then the default presentation shall be listed as the first presentation of all presentations with the same language and audio type. Additionally, SI signalling should include text labels to distinguish them (see section 6.4.4 “Signalling for NGA: Preselections” for further details).

All audio services targeting the same language shall be encoded as AC-4 presentations in one single AC-4 audio stream in order to be selected automatically in the receiver based on the user’s preferences. See section 6.4.4 (Signalling for NGA presentation) and section 6.5 (NGA prioritisation) for further information.

### Multiple languages

If the AC-4 elementary stream contains presentations targeting multiple languages, then the ‘complete main’ or ‘dialogue’ substream group info shall include language information in BCP-47 format by providing at least the primary language subtag info in every frame of each presentation that has a language associated. If a presentation does not have an associated language, e.g. an ambience only presentation, then it shall either not use the language signalling or set the language in the substream\_group info of the CM substream to ‘zxx’ (=“No linguistic content”).

The default presentation of every stream shall be tagged with the target broadcast region language tag, even if the audio remains in the original language but visual subtitles are available for that target language. This approach ensures that the IRD configured to default always selects the default presentation. E.g. if an English movie is transmitted to a Swedish audience with Swedish subtitles, the default presentation sets the language to Swedish (the target language). An additional optional presentation may also set the language to English while referring to the same main audio component.

Note that the AC-4 encoder might set dedicated language tags (in the range of reserved use of *qaa* to *qtz*) to substream groups used for accessibility services (Audio Description or Spoken Subtitles). Those tags are only used by the decoder and have no means to external components.

### AC-4 metadata

#### Loudness

With AC-4, the loudness reference level is transmitted as *dialnorm* in the bitstream’s parameter called *dialnorm\_bits* separately for each presentation. The value of this data field shall represent the measured loudness in LUFS according to ITU-R BS.1770-4 [76] and EBU R 128 [72] for the corresponding presentation.

#### DRC

AC-4 defines multiple DRC decoder modes, each corresponding to a DRC profile and a reference output level. The AC-4 encoder applies and sends all predefined DRC decoder modes. In case neither a specific profile is assigned nor available from input metadata, the AC-4 encoder will apply a default profile value. The following table provides an overview on relevant standard DRC decoder modes, their targeted output level ranges, their mapping from E-AC-3 DRC modes and default profiles:

DRC Decoder Mode	Output Level Range	E-AC-3 DRC Profile	Default Profile
Home Theater	-31 to -27 LUFS	Line Mode	Film Light
Flat Panel TV	-26 to -17 LUFS	RF Mode	Film Standard

Table 6.7.

Note that AC-4 supports additional DRC Decoder Modes targeting portable devices.

### **Downmix metadata**

For decoding channel-based content, when the number of output speakers are less than the number of encoded audio channels, downmixing is required to render the complete audio program.

AC-4 decoders downmix audio according to a standard set of downmix rules. Operators should specify various downmix metadata parameters to control the downmixing process in the decoder.

These parameters include:

- preferred downmix method
- stereo mixdown gains
- LFE downmix
- Downmix gains for channel-based immersive audio

Channel-based Immersive Presentations provide the option to carry custom downmix gains for lower order channel-based immersive output or 5.1 output. Rendering to stereo is always performed as a subsequent downmix from 5.1 using Stereo Downmix Gains

Additionally, the “Previous mix type” metadata is informational metadata used to indicate whether the signal was upmixed or downmixed prior to encoding and if so, what type of algorithm therefore was used.

Operators should consult their encoder provide for detailed guidance on possible downmix metadata.

### **Ducking metadata**

Presentations that consist of a compositional mix include mixing metadata that define the gains for mixing the various components, including M&E and Dialogue mixing and Main-Associated mixing.

For mixing of associated audio, the Dolby AC-4 encoder can generate scaling factors to be applied on the normal audio component based on its built-in ducking algorithm.

Mixing a Dialogue component to a M&E component is equivalent to the use case of Dialogue Enhancement.

### **Dialogue Enhancement**

Metadata to control the Dialogue Enhancement operation should be carefully configured by the broadcasters/operators.

A more detailed explanation of the operating modes of Dialogue Enhancement with AC-4 is described in Appendix C.

## **6.4 Multiplexing audio into MPEG-2 TS and Signalling**

### **6.4.1 PID assignment for audio streams**

In cases where multiple audio streams are intended to be simulcasted for one service, the IRD will prioritise streams with lower PID values in absence of comprehensive signalled information or if all signalling are equal (type (normal, supplementary), language, audio format (stereo/multichannel), stream type (codec)). In consequence, audio streams carrying experiences considered to be of primary interest by most users shall have assigned a lower PID number than those targeting a minor audience.

In particular, lower PID values shall be assigned to:

- Audio streams containing “Normal Audio” services compared to streams carrying “Supplementary Audio” services.
- Audio streams tagged with the primary preferred language of the majority of users in the reception area (=“default language”) compared to other languages.

- Legacy encoding formats compared to newer, more enhanced formats to increase compatibility with receivers based on older versions of the IRD specification

Note: Similar rules for prioritisation also apply to NGA preselections within one NGA stream, where receivers will prioritise, those presentations signalled first.

#### 6.4.2 Codec-format specific signaling

##### **MPEG-1 Layer II**

The value of the **stream\_id** field for MPEG-1 Layer II audio packetized elementary streams shall be 110x xxxx, where each x can be either 0, or 1.

The value of **stream\_type** for MPEG-1 Layer II audio packetized elementary streams shall be 0x03 (indicating ISO/IEC 11172-3 Audio).

Note that MPEG-1 Layer II audio streams do not require an audio\_stream\_descriptor to be present (IRDs uses stream\_type to identify that the stream is MPEG-1 Layer II audio), but an audio\_stream\_descriptor may be present in the ES\_info\_loop of the PMT for the service, see sections 12.6.2 for details.

##### **E-AC-3 and AC-3**

The value of the **stream\_id** field for an AC-3 and Enhanced AC-3 elementary stream shall be 0xBD (indicating private\_stream\_1).

The value of **stream\_type** for an AC-3 or Enhanced AC-3 elementary stream shall be 0x06 (indicating PES packets containing private data). Multiple AC-3 or Enhanced AC-3 streams may share the same value of stream\_id since each stream is carried with a unique PID value.

Note that AC-3 and E-AC-3 audio streams require an ac-3\_descriptor or an enhanced\_AC-3\_descriptor to be present in the ES\_info\_loop of the PMT for the service, respectively. See sections 12.6.5 and 12.6.6 for details.

##### **MPEG 4 HE AAC**

The value of the **stream\_id** field for LATM/LOAS formatted MPEG-4 AAC, MPEG-4 HE AAC and MPEG-4 HE-AAC v2 packetized elementary streams shall be 110x xxxx, where each x can be either 0, or 1.

The value of **stream\_type** for MPEG-4 AAC, MPEG-4 HE AAC and MPEG-4 HE AAC v2 packetized elementary streams shall be 0x11 (indicating ISO/IEC 14496-3 [53] Audio with the LATM/LOAS transport syntax).

Note that MPEG-4 HE-AAC (incl AAC-LC) audio streams require an AAC\_descriptor in the ES\_info\_loop of the PMT for the service, even if some IRDs uses stream\_type to identify that the stream is MPEG-4 AAC audio. See sections 12.6.7 for details.

##### **AC-4**

The value of **stream\_id** in the packetized elementary stream (PES) header shall be 0xBD (indicating private\_stream\_1). Multiple AC-4 streams may share the same value of stream\_id since each stream is carried using a unique PID value.

The AC-4 elementary stream shall be byte-aligned within the PES packet payload. This means that the first byte of an AC-4 frame shall reside in the first byte of the PES packet payload.

One or more AC-4 frames may be packaged into one PES packet, but each PES packet shall contain an integer number of AC-4 frames only. AC-4 frames shall not be split over two or more PES packets.

For an AC-4 elementary stream the value of **stream\_type** in the associated elementary stream loop instance in the PMT shall be set to 0x06 (indicating PES packets containing private data).

Note that AC-4 audio streams require an `ac-4_descriptor` to be present in the `ES_info_loop` of the PMT for the service. See section 12.6.12 for details.

### 6.4.3 Audio related signalling considerations

#### Signalling for targeted language preference

For audio streams coded in either the MPEG-1 Layer II, AC-3, E-AC-3 or HE-AAC format, the preferred language of the targeted audience is signalled using the `ISO_639_language_descriptor` (section 12.6.4 and 12.1.8) or the supplementary audio descriptor (section 12.6.8 and 12.1.8).

If both descriptors are present on one audio stream, the `ISO_639_language_code` of the `supplementary_audio_descriptor` shall match that of the `ISO_639_language_descriptor` unless non-language tags are used for special purposes (see below for details).

NGA streams use the `audio_preselection_descriptor` (section 12.6.11) to signal the targeted languages of each signalled audio preselection. In addition, the `ISO_639_language_descriptor` can be used if IRDs supporting AC-4 but not the `audio_preselection_descriptor` is targeted (early NorDig HEVC IRDs released before July 2020).

Note 1: All NGA experiences targeting one language must be included in one single NGA stream as the IRD will not consider any other stream (neither coded in NGA nor legacy audio format) for presentation selection.

Note 2: In absence of any descriptor (i.e. neither an `ISO_639_language_descriptor` nor an `audio_preselection_descriptor` is present), the NorDig HEVC IRD assumes that all languages are present in the NGA stream and in consequence will select that NGA stream.

Note 3: See section 12.1.8 on additional requirements and guidance on the use of language codes.

#### Signalling for Supplementary Audio (legacy audio only, i.e. non-NGA/non-AC-4)

All Supplementary Audio streams (both Broadcast mixed and Receiver mixed) coded in MPEG-1 Layer II, AC-3, E-AC-3 or HE-AAC format shall be signalled by the broadcaster in the stream by means of the Supplementary Audio Descriptor, see section 12.6.8 (only exception if it is necessary to avoid mis-behaviours in legacy IRDs).

#### Supplementary Audio Signalling using the Supplementary Audio descriptor

In the `supplementary_audio_descriptor`, `mix_type` is typically set to '1'. This applies to stream carrying "Normal Audio", but also to streams providing "broadcast-mixed" accessibility services.

Only secondary audio streams intended to be mixed with a normal audio stream shall signal `mix_type` set to '0' ("receiver mix").

The `editorial_classification` shall indicate the type of the audio stream. Streams carrying "Normal audio" indicate 0x00, while accessibility services audio stream signal 0x01 for Audio Descriptor (AD) or 0x03 for Spoken Subtitles (SS) irrespectively of the `mix_type` employed.

For the `ISO_639_language_code`, the same rules as with the `ISO_639_language_descriptor` should apply.

#### Legacy IRD considerations on Supplementary Audio (informative)

Some (older) IRDs currently in the market (here referred to as legacy IRDs) handle supplementary audio in a variety of ways, and there are some legacy receivers which are unable to elegantly support the presence of Supplementary Audio.

To mitigate this and avoid unwanted behaviour, some Networks use special signalling for the Supplementary Audio. This means for example that in some networks a supplementary audio service carried as a separate broadcast-mixed audio track (PID) is signalled in the `ISO_639_language_descriptor` as 'nar' (= "Narrative") in `ISO_639_language_code` field and 0x00 (= "normal/undefined") in the

audio\_type field. The NorDig IRD recognizes the language code ('nar') and displays the word "Narrative" in the appropriate OSD and menu.

#### 6.4.4 Signalling for NGA: Preselections

For each preselection contained in an NGA audio stream, the audio\_preselection\_descriptor (section 12.6.11) provides a language tag, some flags indicating the availability of accessibility features and an indication on the preferred reproduction layout in addition to an identifier for selection purposes towards the audio decoder. Optionally, preselections should be further differentiated by text labels carried in the message\_descriptor (extension tag 0x08), if the beforementioned parameter doesn't provide a comprehensive differentiation.

Not all presentations in the AC-4 elementary stream need to be reflected as preselections in an APD (audio\_preselection\_descriptor), but only those which are intended to be presented to and selectable by the user. On the other hand, the audio\_preselection\_descriptor may remain unchanged even if certain or all preselections are temporarily not available e.g. during commercial breaks and other interstitials. By this, the number of transitions in SI signalling is reduced compared to signalling within the NGA elementary stream where changes theoretically might occur every audio frame.

Note 1: If a selected preselection disappears, the AC-4 decoder will select an appropriate AC-4 presentation based on the user's preferences until the selected preselection is available again.

Note 2: With NGA, accessibility services are an integral part of the NGA audio stream and therefore no supplementary audio streams will be used. Even if NGA receivers not understanding the APD (audio\_preselection\_descriptor) are targeted, accessibility services need not be signalled by legacy descriptors; those devices are still enabled to select an appropriate preselection from the NGA stream.

Note 3: As stated in section 6.3.5 all NGA experiences targeting one language must be included in one single NGA stream/PID.

For AC-4 audio, Table 6.8 provides a mapping from elements of the APD (audio\_preselection\_descriptor) to corresponding elements in the AC-4 TOC.

APD Element	AC-4 TOC Element
Audio Preselection	ac4_presentation_v1_info()
preselection_id	presentation_id
audio_rendering_indication	Preferred reproduction layout (see below.)
audio_description	Accessibility Service: Audio Description Associated audio ac4_substream_group present with content_classifier of 010b (Associated service: visually impaired).
spoken_subtitles	Accessibility Service: Spoken Subtitles Associated audio ac4_substream_group present with content_classifier of 111b (Associated service: voice over).
dialogue_enhancement	(typically set to '1')
interactivity_enabled	<i>(Reserved for future use.)</i>
ISO_639_language_code	Primary language subtag of the language tag in the main audio or dialogue ac4_substream_group_info of the presentation, converted to ISO 639-2.
Text Label	Recommended but no expression in the elementary stream.

Table 6.8.

Note: The language tags in the AC-4 elementary stream must strictly apply to BCP-47 while the language in the APD (audio\_preselection\_descriptor) is signalled using ISO 639-2 language tags. For example, the BCP-47 code of 'en-US' indicating "English as spoken in the United States" will read 'eng' in ISO 639-2.

Note: The audio\_preselection\_descriptor should only signal "real" languages. Special language tags like "und", "mul", "mis", "qaa" or "nar" should be avoided.

### Preferred reproduction channel layout

The audio\_rendering\_indication in the APD (audio\_preselection\_descriptor) should be set according to the pres\_ch\_mode and the b\_pre\_virtualized bit:

- If pres\_ch\_mode is 0 or 2, then audio\_rendering\_indication shall be set to 1.
- If pres\_ch\_mode is 1 and b\_pre\_virtualized is 0, then audio\_rendering\_indication shall be set to 1.
- If pres\_ch\_mode is 1 and b\_pre\_virtualized is 1, then audio\_rendering\_indication shall be set to 4.
- If pres\_ch\_mode is in the range from 3 to 8, then audio\_rendering\_indication shall be set to 2.
- If pres\_ch\_mode is 9 or higher, then audio\_rendering\_indication shall be set to 3.
- If pres\_ch\_mode is -1, then audio\_rendering\_indication shall be set to 3.

pres_ch_mode	b_pre_virtualized	audio_rendering_indication
0	any	1
1	0	1
1	1	4
2	any	1
3 – 8	any	2
9 – 15	any	3
-1	any	3

Table 6.9.

### Multiple Languages with multiple streams

If audio streams targeting different languages are carried in multiple streams, then the audio\_preselection\_descriptor shall indicate all available languages in the NGA stream.

Additionally, the operator may send an ISO\_639\_language\_descriptor. This may be necessary in order to serve HEVC IRDs not understanding the APD (audio\_preselection\_descriptor).

Note: All NGA experiences targeting one language must be included in one single NGA stream as the IRD will not consider any other stream (neither coded in NGA nor legacy audio format) for presentation selection.

### 6.4.5 Codec specific signalling in the Event Information Table

The type and the editorial characteristics of audio component should be signaled by dedicated component\_types in the component\_descriptor.

The presence of the component\_descriptor in the EIT is optional and up to the broadcaster/operator.

The following table provides an overview on the available component\_types used to characterize related audio components:

Audio codec	configuration	stream_content	stream_content_ext	component_type
MPEG-1 Layer II audio	Mono	0x2	n/a 0xF	0x01
	stereo			0x03
	receiver-mixed audio description			0x47
	broadcast-mixed audio description			0x48
(E-)AC-3		0x4	n/a 0xF	See below
MPEG-4 AAC / HE AAC (1)	Mono	0x6	n/a 0xF	0x01
	Stereo			0x03
	Multichannel			0x05



	receiver-mixed audio description			0x47
	broadcast-mixed audio description			0x48
AC-4		0x9	0x1	0x0E
NGA preselections		0xB	0xE	See below
Note 1: Applicable for MPEG-4 audio streams that conform to the AAC Profile (often referred to as AAC low complexity) and the High Efficiency AAC Profile; not applicable for streams that conform to the High Efficiency AAC v2 Profile.				

Table 6.10: Audio specific component\_type value assignment.

### component\_type for (E-)AC-3 audio modes

For the usage with audio coding modes supported in the scope of the NorDig specification, the component\_type assignments can be simplified as follows:

component_type bits		
b <sub>7</sub> (MSB)	b <sub>6</sub> to b <sub>3</sub>	b <sub>2</sub> to b <sub>0</sub>
<b>E-AC-3 flag:</b>	<b>Service type:</b>	<b>Channel Mode:</b>
0: stream is AC-3	1000: Normal audio	000: Mono
1: stream is E-AC-3	1010: broadcast-mixed AD	010: Stereo
	0010: receiver-mixed AD (supplementary stream)	100: Multichannel (5.1)

Table 6.11.

For example, a normal audio, multichannel 5.1 stream encoded in E-AC-3 uses a component\_type of 11000100 = 0xC4. A supplementary audio stream carrying the receiver-mixed audio description component uses a component\_type of 10010000 = 0x90.

For all other assignments see the DVB SI specification in ETSI EN 300 468 [13].

### component\_type for NGA Preselections

For NGA, one instance of a component\_descriptor should signal the used codec; in particular for AC-4 audio, this descriptor signals stream\_content set to 0x9, stream\_content\_ext 0x1 and component\_type set to 0x0E.

In addition, another instance of the component\_descriptor can be put into the corresponding descriptor loop for each NGA preselection available for the whole service. In this case, with stream content set to 0xB, stream\_content\_ext set to 0xE and component type set according to the following table:

component_type bits		Description
b <sub>7</sub> (MSB)		Reserved zero for future use
b <sub>6</sub>		content is pre-rendered for consumption with headphones
b <sub>5</sub>		content enables interactivity
b <sub>4</sub>		content enables dialogue enhancement
b <sub>3</sub>		content contains spoken subtitles
b <sub>2</sub>		content contains audio description
b <sub>1</sub>	b <sub>0</sub>	Preferred reproduction channel layout:
0	0	no preference
0	1	stereo
1	0	two-dimensional
1	1	three-dimensional

Table 6.12: Next-generation audio component\_type value assignment.

## 6.5 Audio Prioritisation within the NorDig IRD (informative)

### 6.5.1 Audio stream selection

The NorDig IRD is required to always decode and output audio if the selected service has an audio stream (irrespective of type, language, format or codec used). For television services with more than one audio stream, the NorDig IRD is required to prioritise and select the preferred audio stream to decode and present an output according to IRD's user preference settings.

#### NGA

The NGA capable NorDig HEVC IRD is required to prioritise the selection of NGA/AC-4 audio PID/stream over other audio PIDs/streams using other audio codecs when:

- NGA stream signals a language that matches IRD user preference settings for primary audio language. (See section 6.4.4 on language signalling in PMT), or
- NGA stream does not signalise any language (in PMT), or
- No NGA stream matches the user preference settings for primary audio language and no non-NGA stream matches the IRD user preference settings for primary and secondary audio language.

Otherwise, the non-NGA audio PIDs/streams shall be selected in accordance with the information given below.

If the NGA capable NorDig HEVC IRD finds more than one NGA stream that matches the primary audio language or finds that none of the NGA streams match the primary audio language, the NGA stream with lowest PID is selected.

The selection among available presentation/preselections inside the AC-4 stream, is in accordance with section 6.5.3.

#### Legacy / Non-NGA

The NorDig IRD is required to select the preferred audio stream to decode and present an output according to IRD's user preference settings as given in the following table.

IRD settings →		“Normal” audio mode		Supplementary audio mode	
		stereo mode (factory default)	multichannel mode	stereo mode	multichannel mode
IRD behavior depending on above IRD settings					
Property of priority for audio	Priority	Order of priority			
Audio type	1 (highest)	1.1 normal 1.2 supplementary audio	1.1 normal 1.2 Supplementary audio	1.1 supplementary audio 1.2 normal	1.1 supplementary audio 1.2 normal
Language	2	2.1 audio match primay audio language settings 2.2 audio match secondary audio language settings 2.3 (if no match) normal audio 2.4 (if no normal audio) any audio	2.1 audio match primary audio language settings 2.2 audio match secondary audio language settings 2.3 (if no match) normal audio 2.4 (if no normal audio) any audio	2.1 supplementary audio match primay audio language settings 2.2 supplementary audio match secondary audio language settings 2.3 (if no match) normal audio 2.4 (if no normal audio) any audio	2.1 supplementary audio match primay audio language settings 2.2 supplementary audio match secondary audio language settings 2.3 (if no match) normal audio 2.4 (if no normal audio) any audio
Audio format	3	3.1 stereo 3.2 Multichannel 3.3 mono	3.1 Multichannel 3.2 stereo 3.3 mono	3.1 stereo 3.2 Multichannel 3.3 mono	3.1 Multichannel 3.2 stereo 3.3 mono
Stream type	4 (lowest)	4.1 MPEG-1 Layer II 4.2 HE-AAC 4.3 E-AC-3 4.4 AC-3	4.1 HE-AAC 4.2 E-AC-3 4.3 AC-3 4.4 MPEG-1 Layer II	4.1 MPEG-1 Layer II 4.2 HE-AAC 4.3 E-AC-3 4.4 AC-3	4.1 HE-AAC 4.2 E-AC-3 4.3 AC-3 4.4 MPEG-1 Layer II

Table 6.13: Audio Priority between incoming audio streams where a lower number refers to higher priority.

The IRD uses information from the PMT in order to select the appropriate audio stream or PID according to the user receiver preferences (Audio type, Language, Audio format, Stream type) if several audio streams or PID’s are available. After selecting audio PID to be decoded, the IRD uses the audio metadata (PES/ES header or bitstream) within the audio stream for the decoding process. And this audio metadata (PES/ES header or bitstream) is normally more dynamic, (such as changing audio format between stereo and multichannel, downmix parameters, etc.). This means that the IRD does not use the EPG/EIT data for selecting the audio stream or PID, nor for the actual decoding. The information within the EIT/(EPG) regarding the audio is only intended for presentation to the viewer, e.g. EPG information. The values in

the PMT should be more quasi static and describing the maximum use case (e.g. multichannel if the audio stream is dynamically changing between stereo and multichannel).

#### 6.5.2 Audio Prioritisation, Format (multichannel or stereo)

The intention for the setting “Stereo” and “Multichannel” is to enable the user to set up the IRD to select the appropriate audio stream to suit their preference. Some broadcasters employ only stereo audio, others use stereo and multichannel and some use stereo audio and multichannel audio that rotates between the two depending upon the content (viz. from stereo up to 5.1). More combinations with Audio Description (AD) or Spoken Subtitle audio stream content may also be present.

It is deemed importance that the receiver behaves in an elegant manner that it does not change audio stream type dependent up on how the content itself may have been produced.

The intention is that the IRD adheres to an audio stream type in a semi-constant way, after the IRD has selected which audio stream type to decode and the IRD begins to decode the audio stream, only then does the audio decoder read and applies the Channel Mode audio metadata (e.g. for AC-3) to the appropriate outputs (can be stereo output to the TV-loudspeakers and multichannel bitstream to the digital audio output). It is therefore defined that the IRD must read the AAC\_type field in the AAC\_descriptor for AAC audio, and the number of channels flags in the AC-3 descriptor and Enhanced AC-3 descriptor for AC-3 and E-AC-3.

#### 6.5.3 Presentation selection from NGA streams

Once the IRD has selected an NGA audio stream for decoding, the desired presentation from that stream is selected by two mechanisms:

Per default, the IRD selects the most appropriate presentation based on the user’s preferences. This is based on the information contained in the ac4\_toc in the elementary stream.

Additionally, the user may select a presentation from the list of available presentation signalled in the audio\_preselection\_descriptor (optionally enriched by textual descriptions from message descriptors) (1). Based on this signalling, the user interface can inform the NGA/AC-4 decoder about the user’s selection through a unique identifier.

If the signalled choice is temporarily unavailable - for instance during an advertisement break - the AC-4 decoder will instantaneously fall back on the user-preferences based presentation selection based on information from the ac4\_toc to provide a seamless experience to the listener and will revert the personalised choice once it becomes available again.

Note 1: Optional for NorDig HEVC IRDs launched before 1 July 2020.
--

Table 6.14 uses the terminology from the Audio Preselection Descriptor, however the ac4\_toc is used for audio prioritisation based on user preferences. The ac4\_toc functionality is typically part of audio decoder components. Therefore, the corresponding properties for Audio Type and Language are used which are described in the section above.

IRD settings →	Audio Description (AD) OFF		Audio Description (AD) ON	
	Spoken Subtitles OFF	Spoken Subtitles ON	Spoken Subtitles OFF	Spoken Subtitles ON
IRD behaviour depending on above IRD settings and preselection properties				
Priority	Priority with respect to best matching preselection		Priority with respect to best matching preselection	
1	AD off and SpS off Preselection matching primary audio language	AD off and SpS on Preselection matching primary audio language	AD on and SpS off Preselection matching primary audio language (†)	AD on and SpS on Preselection matching primary audio language
2	AD off Preselection matching primary audio language	SpS on Preselection matching primary audio language	AD on and SpS on Preselection matching primary audio language	AD on and SpS off Preselection matching primary audio language
3	Preselection matching primary audio language	Preselection matching primary audio language	SpS off Preselection matching primary audio language	SpS on Preselection matching primary audio language
4	AD off and SpS off Preselection matching secondary audio language	AD off and SpS on Preselection matching secondary audio language	Preselection matching primary audio language	Preselection matching primary audio language
5	AD off Preselection matching secondary audio language	SpS on Preselection matching secondary audio language	AD on and SpS off Preselection matching secondary audio language settings	AD on and SpS on Preselection matching secondary audio language
6	Preselection matching secondary audio language	Preselection matching secondary audio language	AD on and SpS on Preselection matching secondary audio language	AD on and SpS off Preselection matching secondary audio language
7	(if no match) default Preselection	(if no match) default Preselection	SpS off Preselection matching secondary audio language	SpS on Preselection matching secondary audio language
8			Preselection matching secondary audio language	Preselection matching secondary audio language
9			(if no match) default Preselection	(if no match) default Preselection

*Table 6.14: Audio Priority between NGA Preselections for NGA “Accessibility Services” with Audio description on/off and Spoken Subtitles on/off. A lower number refers to higher priority.*

Differentiation of audio formats is not relevant for prioritisation of presentations since the NGA decoder provides renderers for kinds of playback scenarios.

## 7 Teletext and Subtitling

### 7.1 General

DVB Subtitling (ETSI EN 300 743 [17]) and EBU Teletext Subtitling (ETSI EN 300 706 [16]) are mandatory in the NorDig IRDs. NorDig HEVC IRDs shall also support TTML subtitling (ETSI EN 303 560 [94]).

The user **shall** be able to enable and disable displaying of subtitles and to select primary and secondary subtitling language, see sections 7.1.2, 7.3 and 7.4.

Subtitling may be provided through ITU-R system B Teletext, DVB Subtitling System and/or through the TTML Subtitling System [94].

For TV services that has TTML subtitling it is recommended to also simulcast a “copy” of the subtitling in EBU Teletext subtitling or DVB Subtitling format, this to ensure that all IRDs can present subtitling for the viewers (even for IRDs not supporting TTML).

#### 7.1.1 Wordings and definitions for subtitles

EBU Teletext, DVB Subtitling and DVB TTML specifications are using different wordings for the different types of subtitling. See table 7.1 below for NorDig’s wording and the relationship to EBU Teletext, DVB and TTML subtitling specifications.

Wordings related to subtitling				
NorDig	EBU Teletext	DVB Subtitling	TTML	Interpretation
Translation dialogue subtitles (or Normal subtitles)	(0x02) subtitling	Normal subtitles	Translation dialogue subtitles	Subtitles that includes a translation of foreign language dialogue
Non-translation dialogue subtitles	-	-	Non-translation dialogue subtitles	Subtitles that includes a transcription of same language dialogue
Hard-of-hearing subtitles	(0x05) subtitle for hearing impaired  (common to also carry any non-translation dialogue)	Hard of hearing subtitles  (common to also carry any non-translation dialogue)	Hard-of-hearing subtitles	Subtitles that includes descriptions of non-dialogue sounds. (e.g. gun fire, explosion, lions roar).
Audio Description subtitles	-	-	Audio Description subtitles	Subtitles that includes description of the visual scene. (e.g. “a lion lies in the sun.”). Intended for text-to-speech.
Content-related commentary subtitles	-	-	Content-related commentary subtitles	Subtitles that includes commentary related information. (e.g. director’s commentary).

Table 7.1 Wordings related to subtitling.

*Informative: For EBU Teletext and DVB Subtitling broadcasters often includes the ‘non-translation dialogue’ subtitles as part of their hard-of-hearing subtitling stream. In order to handle that IRDs only decode one EBU Teletext or DVB Subtitling stream/page at the time, the broadcaster may typically also include the translation dialogue (‘normal’) subtitles into the hard-of-hearing subtitling stream so the hard-of-hearing stream becomes complete.*

**Note:** In some other markets where audio dubbing is frequently used and/or translation dialogue is always burnt-in into video, may refer DVB Subtitling “normal subtitles” for non-translation dialogue subtitles.

### 7.1.2 NorDig IRD Subtitling user preferences

The NorDig IRD will at least have user selection of subtitling preferences for 'translation dialogue' ('normal') and 'hard-of-hearing' subtitles. The NorDig HEVC IRD is additionally recommended to have a third user setting of subtitling preferences for 'non-translation dialogue' subtitles'.

**Note:** Correct functionality for the Hard-of-Hearing/hearing impaired service, requires that the Content Providers delivers this service as a mix of translated subtitling and Hard of Hearing/hearing impaired subtitling since the IRDs typically only decode and present one subtitling stream at the time, see section 7.1.5 Subtitling mode.

#### 7.1.3 Only display subtitling if match language in user preferences

Not Applicable for RoO.

#### 7.1.4 Temporary changes to subtitling settings

Not Applicable for RoO.

#### 7.1.5 Subtitling mode (Normal and Hard of hearing subtitling)

##### 7.1.5.1 Hard-of-hearing stream should include Normal and Hard-of-hearing subtitles

It can be expected that the IRDs only decode and present one subtitling stream at the time (depending of user preference settings). If the broadcaster wants that the "Hard-of-Hearing" viewers get displayed both translation/normal subtitles and hard-of-hearing subtitles, then the hard-of-hearing subtitle stream needs to include the normal subtitles as well (unless the translation/normal is burn-in into video).

##### 7.1.5.2 Signalling for Subtitling stream only carrying Hard-of-hearing subtitles (ie no Normal subtitles)

For Subtitling streams/PIDs that only includes Hard-of-hearing (HoH) subtitles and/or Non-translation dialogue subtitles (i.e. no translation/normal subtitles or if translation/normal is burn-in into video), it can sometimes be recommended in the subtitling descriptor (Teletext/DVB Subtitling/TTML descriptor) to signalise a Normal/ Translation dialogue subtitle page pointing to an empty/unused page. This to prevent that IRDs (with not fully compliant IRD implementation) to display HoH subtitles for viewers that has IRD settings translation/normal subtitling 'on' but HoH subtitling 'off'. This can typically be added to the signalling if and when viewer complains occurs (unless the IRD manufacture(s) can correct its subtitling implementation and send update to these misbehaving IRD model(s)).

#### 7.1.6 Simultaneous subtitle streams/PIDs

A TV service may broadcast subtitling in multiple formats in parallel (EBU, DVB and/or TTML subtitling) over multiple streams/PIDs. If more than one subtitle stream/PID with the same language code is broadcasted for a service, the NorDig IRD will only display a single subtitle stream/PID and select the subtitle stream based on the priority shown in the table below.

Subtitle stream	IRD Subtitle priority (1 = highest)
EBU Teletext subtitling	3
DVB Subtitles	2
TTML Subtitles (1)	1
Note 1: Only mandatory for Nordig HEVC IRD	

Table 7.2 Subtitle priority.

### 7.1.7 Simultaneous EBU Teletext and HbbTV Digital Teletext

A service may simultaneously transmit EBU Teletext normal pages and HbbTV Digital Text/Teletext service. NorDig HbbTV IRDs is required to be able to start and display the HbbTV Digital Teletext application as well as being able to start and display the EBU Teletext service (one at a time) and toggle between the two (typically via multiple presses on TEXT key).

### 7.1.8 Simultaneous Subtitling and HbbTV

A service may simultaneously transmit Subtitling (EBU Teletext, DVB and/or TTML subtitling) and (broadband or broadcast) HbbTV applications. The NorDig HbbTV IRD is required to handle and display the HbbTV application over the subtitles.

## 7.2 **EBU Teletext**

### 7.2.1 General

If EBU teletext is employed by the NorDig service it shall conform to the standard defined in ITU-R System B Teletext in DVB Bitstreams, for SDTV services teletext data shall be inserted on lines 6 to 20 and 318 to 334 only.

Two restrictions apply when considering transmission of teletext for on-screen display:

- The size of the text «packet» that can be handled correctly in the IRD.
- The time delay for presentation of text in real time.

For services intended for transcoding to PAL teletext must be inserted such that allowable lines in the recorded PAL signal are utilised. The exact line numbers to be used must be established in each particular case.

PES packets containing the teletext data **shall** not exceed 1504 bytes in length. A maximum of two fields per PES packet shall be transmitted.

### 7.2.2 EBU Teletext Subtitling

For SDTV services EBU Teletext Subtitling shall not be supplied or transmitted on line 21 of the VBI by the broadcaster on the NorDig compliant network.

For services using EBU Teletext for carrying only subtitling page content (and not providing normal Teletext page content), it is recommended that the EBU Teletext stream anyway includes at least one empty or static normal Teletext page (including signalling to this page as initial page in the teletext descriptor) OR at least include an initial page in the teletext descriptor (pointing to one of the subtitling pages). Some IRDs might have difficult to present subtitling or do not to let viewer manually open Teletext and access the subtitling page, when the teletext stream doesn't have any normal teletext page.

In order to ensure acceptable delay in the presentation of the subtitles the following rules must be observed:

- For a teletext service carrying a mix of text and subtitles no restriction other than that given in section 7.2.1 applies.
- In a subtitles-only teletext service the PES packets must be limited to contain those text pages that shall be displayed simultaneously (multiple language subtitling). Moreover, those text pages must fill an entire PES packet, with the aid of stuffing bytes if necessary.

## 7.3 **DVB Subtitling-System**

The use of DVB subtitling is supported by the NorDig set-top boxes according to ETSI EN 300 743 Digital Video Broadcast (DVB) subtitling systems [17].

### 7.3.1 Hearing impaired

A separate stream marked with “hearing impaired” can be transmitted in addition to the translation/normal subtitle stream on the same language.



It can be expected that the IRDs only decode and present one subtitling stream at the time (depending of user preference settings). If the broadcaster wants that the “Hard-of-Hearing” viewers to get displayed both translation/normal subtitles and hard-of-hearing subtitles, then the hard-of-hearing subtitle stream needs to include the normal subtitles as well (unless the translation/normal subtitles are burned-in into video).

### 7.3.2 Cumulative subtitles

For DVB subtitles only the last word can be transmitted when the previous part of the subtitle is equal. Assumption is made that the receiver shows the whole subtitle including the last word.

### 7.3.3 HD subtitles

The resolution of subtitles shall not exceed the picture resolution, but it can be less.

Following resolutions are available: 720x576i25, 1280x720p50, 1920x1080i25.

When subtitles have lower resolution than the picture, the subtitle shall be scaled to the picture resolution.

### 7.3.4 PCR timing

Subtitles shall be transmitted with increasing display-time. Display-time shall be no more than 10 seconds ahead.

## 7.4 ***TTML Subtitling-System***

It can be expected that the IRDs only decode and present one subtitling stream at the time (depending of user preference settings). If the broadcaster wants that the “Hard-of-Hearing” viewers to get displayed both translation/normal subtitles and hard-of-hearing subtitles, then the hard-of-hearing subtitle stream needs to include the normal subtitles as well (unless the translation/normal subtitles are burned-in into to video).

The use of TTML-DVB subtitling is supported by the NorDig set-top boxes according to ETSI EN 303 560 Digital Video Broadcasting (DVB) TTML subtitling systems [94].

The subtitle purpose field shall be used to specify the purpose of the subtitle.

Subtitles with “0x01 other-lang-dialogue” must also be transmitted with “0x11 other-lang-dialogue with-hard-of-hearing” so the IRDs in the hard-of-hearing mode will display them.

Subtitles with “0x00 same-lang-dialogue” must also be transmitted with “0x10 hard-of-hearing” so the IRDs in the hard-of-hearing mode will display them.

Subtitles only for hard-of-hearing shall only be transmitted with “0x11 other-lang-dialogue with-hard-of-hearing” or “0x10 hard-of-hearing”. Broadcaster should avoid the use of downloaded fonts.

## **8 Interfaces and Signal Levels**

Not Applicable for RoO.

## 9 Conditional Access

### 9.1 General

NorDig services/content may need to be protected for commercial or legal purposes (typically for Pay TV purposes or geo-blocking in satellite “Free To View”/“free-scrambled” service). Protection is achieved through scrambling of the video, audio and services to be transmitted. NorDig recommends that a conditional access solution based on the DVB CSA (Common Scrambling Algorithm) v2 or v3 is used. Conditional Access vendors provide the solutions enabling scrambling, user’s management and security for the level of protection required.

The NorDig IRD used for scrambled services, typically uses Common Interface Plus (together with a CA Module/CAM) and/or Smart Card interface for conditional access / descrambling of the scrambled services. (Some IRDs/STBs may implement a complete embedded CA System function with SmartCard-less/“built-in” SmartCard function).

See section 4.2 for the DVB descrambling.

### 9.2 Use of the Common Interface

#### 9.2.1 General

(For software update of the CAM inside an IRD see section 10 System Software Update).

The Common Interface between the IRD and the CICAM has limitations in capacity/bandwidth that they can handle. Common Interface as defined in CI Plus Specification 1.2 **Error! Reference source not found.** imposes that Hosts support a minimum of 72Mbps and up to 96Mbps, and CICAM a minimum of 96Mbps. (1)

The NorDig Broadcaster should ensure that each MPEG TS containing Conditional Access scrambled services in their network does not exceed the maximum supported bitrate in the Common Interface of the NorDig IRD and CICAM in their market, especially if their network contains legacy IRD and/or CICAM.

*Informative: The Common Interface typically receive and return at its interface the complete MPEG Transport Stream (TS) for the selected service that the IRD is scanned into (often a Multi Program Transport Stream, MPTS).*

CI Plus LLP has the CI Plus Specification [64] and the CI Plus ECP Specification [96]. NorDig IRDs are required to comply with the CI Plus Specification [64] whilst NorDig HEVC IRDs are required to additionally comply with the CI Plus ECP specification [96].

CI Plus LLP has in 2017 released a higher Security Level intended to satisfy the content industry’s stricter requirements to support premium content called CI Plus ECP (Enhanced Content Protection). CI Plus ECP provides an additional level of local protection of the content in the interface between the CIP-CAM and the NorDig IRD. As this is only expected to be supported within the NorDig HEVC IRD, it is typically expected to be used along with the new TV formats coming with HEVC including UHD and/or HDR (BT.2100 [89]).

ECP only operates when an ECP compliant CICAM works in conjunction with an ECP compliant IRD. When a non-ECP device is interfaced with an ECP device, the Common Interface can only support non-ECP protection.

NorDig (PayTV) operators requiring the use of CI Plus ECP must ensure that the viewers are equipped with both an IRD and an CAM compliant with ECP. In case only one of the devices is ECP compliant, the NorDig Broadcaster must ensure that the viewer is in no doubt as to the reason why the ECP protected service is not available to the viewer, (the Operator shall ensure that the IRD manufacturer is not

contacted by the viewer for such troubleshooting). The NorDig Broadcaster should consult with the IRD manufacturers to confirm that their messages and their remedies are acceptable to the IRD manufacturers.

Note (1): Legacy NorDig IRDs with Common Interfaces that do not support CI Plus may have further bandwidth limitation down to 54Mbps. NorDig Broadcasters should verify that their transmission will be interpreted as they intend by testing these IRDs.

### 9.3 Use of Smart Card Reader (IRD and CA Module)

The role of the Smart Card in the NorDig IRD is to decrypt and store the content of the EMM for the subscriber. These EMM permit the identification of the scrambled services that the NorDig IRD is authorised to decrypt. Based upon this information, the Smartcard can decrypt the ECM of the authorised services, in order to provide the decryption keys for unprotecting of the scrambled services.

*Informative: The NorDig IRD or the CICAM extract the ECM and EMM, and may transmit either all, or some of these messages to the Smartcard. Section 4.2 of the present document explains how to manage the data bandwidth from the incoming EMM stream(s) to the smartcard interface in case all EMMs are passed to the Smartcard.*

While the IRD should perform filtering of the appropriate EMM and ECM for selected services, the NorDig Broadcaster should consider that not all IRD or CA Modules may have enough filters for multiple EMM and ECM for the same service. This may prevent these IRD or CA Modules from retrieving the required EMM and ECM for the protected service and would deny the IRD from unprotecting the service, thus denying the viewer from viewing authorised services.

The services are protected using the DVB CSA which scrambles the content using keys carried in the ECM.

The ECM should be signalled in the PMT, and the EMM should be signalled in the CAT.

One service may signal multiple ECM and/or EMM from the same CA system, e.g. for different generations of the same CA System.

NorDig Broadcasters should consider the limitation of the number of PIDs in regard to the NorDig IRD and the Conditional Access system deployed in their market. A NorDig IRD must be able to filter a minimum of 6 services (PID), as defined in section 4.2. A NorDig IRD may not be able to filter more than this number.

Special care should be taken in the case of Simulcrypt. For example, multiple generations of the same Conditional Access System may require their own EMM and ECM each, which may cause an issue with filtering. Conversely, multiple Conditional Access Systems to protect one service may not cause such restriction.

NorDig Operator should ensure that the EMM and ECM streams does not exceed the maximum supported bitrate of the Smart Card interface for the IRD and CICAM in their market.

NorDig Operator should ensure that PMT and CAT signalling do not request more CA filtering than the NorDig IRD and CA Modules in their market can handle.

## 10 System Software Update (SSU)

### 10.1 System software

The system software update (SSU) of the NorDig IRD and of the DVB CA Module (CAM with CI/CIP) can use different delivery alternatives for the update, main alternatives are:

- Over-The-Air, OTA (also referred to as Over-Air-Download/OAD), refers to system software update via broadcast channel. Classical/historical delivery alternative mainly used for legacy and non-Internet-connectable IRD and when need to reach non-connected connectable IRDs. This remains often the common delivery alternative for system software update of CA Modules (via the IRD's Common Interface).
- Over-The-Network, OTN, refers to system software update via the broadband/internet channel via the IRDs two-way interface. This delivery alternative is common for most connectable (NorDig) IRDs. NorDig Connected Connectable IRD will arbitrate between OTA and OTN to select the newest version of the software update according to the NorDig Unified Requirement [116] section 10.1.4.2.
- Local update, via e.g., USB interface.
- A mix of delivery alternatives to support updates exist, for example using OTA to deliver information/notification for the viewer about available new software (e.g. to reach connectable IRD that for various reasons have no connection to Internet), which the user can initiate using OTN or local download, see section 10.2 below.

OTN delivery is recommended for Connectable IRDs as it is faster and more efficient than OTA especially since the rapidly evolving service proposition for a connected IRD may necessitate regular updates. OTA may still be needed for Connectable IRDs, for example for important updates to reach non-connected Connectable IRDs or rural areas/viewers with restricted/limited broadband internet connection with data plan etc. It could for example be that OTA part is used only to deliver short information/notification to the viewer about an (important) update available with the actual system software may be delivered via OTN or USB memory stick.

The NorDig IRD system software may constitute a complete system, i.e., drivers, operating system and applications, or individual system components like updated parts of the system software or new applications.

The Software of CIP CAM can also be updated; this requirement is described in section 10.5.5.

Non-connected connectable IRDs may be informed of the availability of new software by use of the SSU notification feature (using an update\_type of 0x04 in the system\_software\_update\_info structure), where a broadcast UNT signals the availability of software updates from the Internet.

The NorDig Operator **should** be aware that IRD manufacturers will have selected which Delivery alternative(s) and Approach for System Software Update each specific NorDig IRD model supports and specific details needed for SSU (Generally this varies between brands and models. It is also common that IRD only support some of the listed delivery alternatives).

*Note: Informative: as mention in section 1.3 of the NorDig Unified IRD Specification [116] regarding **connectable/non-connectable IRD**; A Connectable IRD refers here to an IRD that includes a two-way interface (e.g. WiFi, Ethernet, Eurodocsis etc) typically with access to Internet, a "Smart TV" or a TV with HbbTV is typical examples of connectable IRDs. A connectable IRD that has connected and activated the two-way interface is here referred to as connected IRD (i.e. a connected connectable IRD), while a connectable IRD that has not connected or activated the two-way interface is referred to as non-connected connectable IRD.*

Note: The NorDig IRD may in addition to below requirements have other alternatives related to update of the IRD's system software.

#### 10.1.1 User control of SSU (by the NorDig IRD user)

Informative: The NorDig IRD software update has to be initiated and enabled by the NorDig IRD user. The NorDig Operator **should** not assume that an OTA will be received and installed simply because it is transmitted.

#### 10.1.2 SSU procedure

Informative: The NorDig IRD are required to have mechanisms to identify that SSU are available for them, and notify the NorDig IRD user of the available update, as well as mechanisms for enabling the NorDig IRD user to enable the update.

For OTA SSU the NorDig Operator **should** make itself aware of the methods used by each of the manufacturer of NorDig IRD using OTA/OAD SSU in their network to enable their support teams help users in need.

#### OTN vs OTA/OAD organisation/parties and delivery:

- **OTN:** the IRD manufacturers are (generally) in control of the whole delivery procedure down to the IRD.
- **OTA/OAD:** the IRD manufacturer delivers the SSU file, description and/or notifications to the Network Operators of the various broadcast networks. In turn, the Network Operators broadcast the SSU file and set the corresponding signalling in the broadcast network, see more in 10.5 below.

#### 10.1.3 User messaging for SSU (by the NorDig IRD to the user/viewer)

No RoO specific.

#### 10.1.4 Security requirements for SSU

For OTA/OAD SSU, the NorDig Operator **should aim to** ensure the SSU available is a certified system-software as NorDig IRD will prevent download of non-certified system-software (for example asking the NorDig IRD vendor for confirmation).

Informative: The NorDig Operator **should** be aware that NorDig IRD will not allow SSU to a software version older/lower than the one they are currently using.

#### 10.1.5 Previous user settings and installation after SSU (for the NorDig IRD)

No RoO specific

#### 10.1.6 Rejection and Reminder for SSU (for the NorDig IRD)

No RoO specific

Informative: The NorDig Operator **should** be aware that the NorDig IRD user will be reminded that the SSU is available each time the user comes out of standby or shutdown, unless the NorDig IRD user selected to permanently reject the update.

#### 10.1.7 IRDs with access to multiple SSU services

No RoO specific

## 10.2 SSU functionality

NorDig (NorDig Unified Requirement [106]) has defined different parts of the SSU procedure, among which that could be of interest for the Network Operator are:

- **Search:** The NorDig IRD searches for and detects if new System Software Update is available for itself (from broadcast, local interface and/or IP-based interface)
- **Download:** The NorDig IRD downloads (caches) the System Software Update data file(s) (from broadcast, local interface and/or IP-based interface).

NorDig has defined following combinations of Search and Download for the SSU.

	Delivery alternatives
#D1	<b>OTA search + OTA download,</b> The IRD is required to search for and download system software from the broadcast channel, see section 10.5
#D2	<b>OTA search + OTN download,</b> The IRD is required to search for system software from broadcast channel and download from return channel (DVB's SSU Update_type 0x03), see section 10.5
#D3	<b>OTA notification + OTN/local download,</b> The IRD is required to search/get notification from broadcast channel (DVB's SSU Update_type 0x04) and download from Internet/broadband channel and/or local interface (e.g. USB), see section 10.5.4
#D4	<b>OTN search + OTN download,</b> The IRD is required to search for and download system software from the Internet / broadband channel, see section 10.3.
#D5	<b>Local search + Local download,</b> The IRD is required to search for and download system software from the local interface (e.g. USB), see section 10.3.

Table 10.1 Delivery alternatives.

### 10.2.1 SSU approaches (for the NorDig IRD)

Informative: The NorDig Unified IRD specification [116] has defined that a NorDig IRD may use a number of different 'approaches' for how it performs its SSU update:

- Fully Automatic (automatic search, automatic download and automatic install).
- Semi-Automatic (Automatic search, automatic download and manual install)
- Automatic search, manual download and install
- Manual search, manual download and install
- Automatic Notification, manual download and install

## 10.3 System Software Update via local interface or IP-based interface (Internet)

### 10.3.1 System Software Update via local interface (e.g., USB)

The NorDig Operator **should** be aware that NorDig IRD manufacturers may make SSU available through their own mechanism (eg download from a website) to enable SSU using local data interface (like USB). Generally, the IRD manufacturers are in control of the whole delivery procedure down to the IRD for this alternative. In some cases, this could be complemented by sending a Notification via the Broadcast channel in order to reach more viewers about this new system software, as stated above.

The NorDig Operator **may** want to ensure they understand how to support their users with these options.

### 10.3.2 System Software Update via IP-based interface (to Internet)

The NorDig Operator **should** be aware that NorDig IRD manufacturers may make SSU available through their own mechanism to enable SSU via the internet. Generally, the IRD manufacturers are in control of the whole delivery procedure down to the IRDs for this alternative. In some cases, this could be complemented by sending a Notification via the Broadcast channel in order to reach more viewers about this new system software, as stated above.

The NorDig Operator **may** want to ensure they understand how to support their users with these options.

### 10.4 **Network Management and Provisioning for IP-based IRDs (IPTV)**

NorDig Operators of IP-based networks who do not have a specific agreement with the IRD vendor **are recommended to** implement SSU through network management and provisioning as specified in ETSI TS 102 034 [29], Chapter 10.

Note: Network management and provisioning specifies how NorDig IRDs with an IP-based front-end network configuration are required to be provisioned, and how NorDig IRDs with an IP-based front-end will be managed over an IP network.

### 10.5 **System Software Update via broadcast channels**

Where System Software Update via broadcast channels (OTA/OAD) is used, the IRD manufacturer needs to deliver to the Network Operator(s):

- An agreement has to be established between the IRD manufacturer and Network Operator(s) for the actual OTA SSU.
- The IRD manufacturer typically has to create/packetize the SSU file (e.g., as a binary MPEG2 TS file), send it to the Network Operator(s) including description for playout and necessary DVB signalling (e.g. content of the SSU linkage like OUI value etc).
- The Network Operator typically has to prepare, plan schedule and allocate necessary capacity inside his DVB broadcast network and have necessary technical system for the playout of SSU data file and add SSU signalling (NIT, PMT etc).

<b>OTN via Network channel</b>	<b>IRD manufacturer</b>	< >	<b>Delivery network</b>	< >	<b>Viewers</b>
	SSU System		e.g. <b>Internet</b>		<b>IRD</b>
		< request > SSU delivery		< request > SSU delivery	User initiated
<b>OTA / OAD via Broadcast channel</b>	<b>IRD manufacturer</b>	< >	<b>Network Operator</b>	>	<b>Viewers</b>
	Create SSU file	e.g. FTP	Broadcast network		<b>IRD</b>
		- Agreement - SSU file transfer - Description of > SSU playout > DVB signaling		- Schedule - DVB capacity - Broadcast network > SSU playout > SSU signaling	User initiated IRD search

Table 10.2.

The NorDig Operator shall not broadcast an Over The Air download without Organisation Unique Identifier (OUI). If the Generic DVB OUI is not used in the NIT, the manufacturer shall supply the relevant NIT information, likewise for the data\_broadcast\_id\_descriptor within the PMT.



**Playout:** It is recommended that OTA/OAD playout of SSU (actual SSU file or notification information) is broadcast for a relevant duration (e.g., 4-5 weeks or longer) in order to reach as many of the IRD as possible. It is also recommended that system software updates take place overnight, where there is lower prospect of interfering with normal viewing (this refers to e.g. that OTA take broadcast bandwidth/capacity otherwise used for the TV services and this schedule function also depends if the IRD support this or not).

The NorDig Operator **should** be aware that the NorDig IRD that support SSU via broadcast channel do so in accordance to DVB SSU Specification [28] Simple Profile and part of the SSU Enhanced Profile described below. The NorDig Operator **shall** only use these profiles.

**Automatic search:** SSU Simple profile (see 10.5.1.1 below) is used for the SSU to be immediately processed as stated in this section 10.5 while SSU Enhanced profile (see 10.5.1.2 below) is used to schedule a time for a download to be available.

The NorDig IRD will search for new software via the broadcast channel according to the Delivery Alternatives stated in 10.2 using:

- For continuously/frequently search, search in the PSI/SI of the actual received broadcast signal(s).
- For search at least once per day and search at least once from the time IRD has been turned off until the time it has been turned on, this refers to search/scan through all installed Transport Streams.

Note: In some cases, the legacy system software implementations are regarded as specific for the different network operators. For this case, it should therefore not be possible for the user to download system software which is targeted for the set-top boxes in another network. To obtain this, the download signalling should contain a reference to a specific hardware version of the relevant manufacturer.

## 10.5.1 SSU Signalling

### 10.5.1.1 Simple Profile (update\_type 0x0 and 0x1)

The NorDig Operator supporting SSU via broadcast channel **shall** support the DVB SSU simple profile using the signalling in NIT, BAT and PMT, in accordance with the DVB-SSU specification [28]. The Linkage descriptor in the NIT table, for linking to the SSU service is defined in section 12.2.6 (The UNT is not used for this profile, see chapter 5 of ref ETSI TS 102 006 [28]).

For NorDig IRD SSU by OTA/OAD, the NorDig Operator **shall** transmit and signal according to ETSI EN 102 006 [28], with the minimum level of functionality of “simple profile”.

Simple profile SSU is signalled using the Network Information Table (NIT) and Programme Map Table (PMT):

- The NIT shall carry the linkage\_descriptor (tag 0x4A) with linkage type 0x09, and either user defined private data to indicate Organisation Unique Identifier (OUI) or signal generic DVB (0x00015A) as described in EN 102 006 [28].
- The PMT **shall** carry the data\_broadcast\_id\_descriptor (tag 0x66) with value 0xA “system software update” for the planned system software update service.

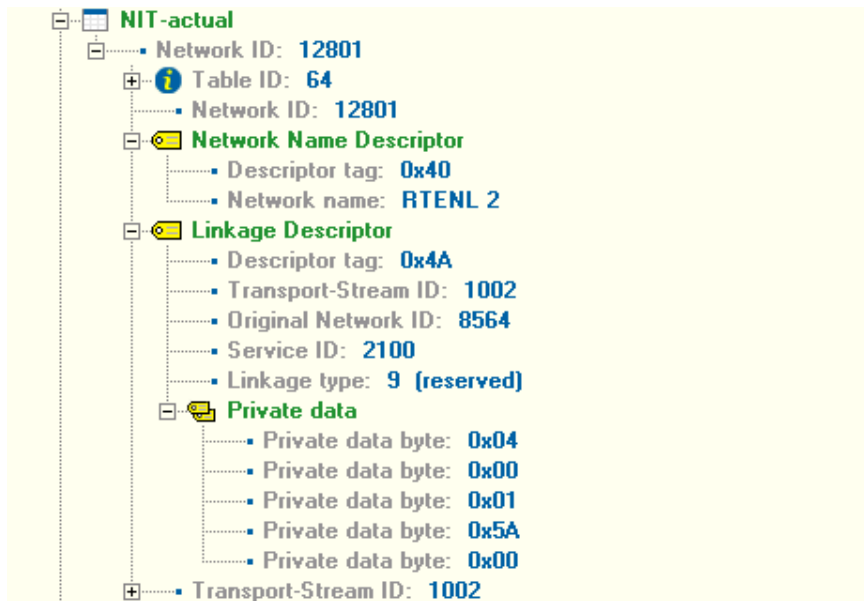

Figure 27: Example of linkage descriptor carried within the NIT.

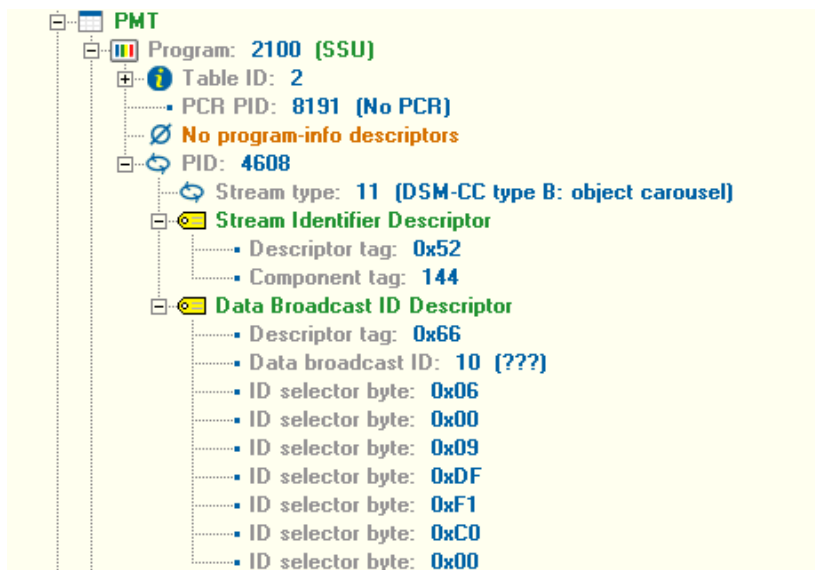

Figure 28: SSU stream\_identifier and data\_broadcast\_id descriptors within the PMT.

#### 10.5.1.2 UNT Enhanced Profile (update\_type 0x2, 0x3 and 0x4)

The NorDig operator supporting SSU download via broadcast channel **shall** support the DVB SSU UNT Enhanced profile using the signalling in NIT, (BAT), PMT, and UNT, in accordance with the DVB-SSU specification [28]. The Linkage descriptor in the NIT table, for linking to the SSU service is defined in section 12.2.6. The descriptors of the UNT Enhanced profile are specified in Section 12.7.

Descriptors defined in the DVB SSU Enhanced profile [28], but not specified as mandatory in section 12.7 may be omitted.

A UNT may contain multiple UNT sub-tables for multiple OUI and OUI\_hash).

#### 10.5.1.3 Locating the Appropriate SSU

NorDig IRD support one or both of the below two principal ways of signalling SSU for OTA/OAD (depending upon what the IRD Manufacturer has selected for a specific NorDig IRD).

1. Use of DVB OUI (DVB's generic OUI value 0x00015A, information: in this case, the IRD finds and selects the appropriate SSU by further investigating into PMT (and also UNT if Enhanced profile is used).
2. Use of Manufacturer specific OUI (information: in addition, selector\_bytes may be used to indicate model type or ranges of models according to the table below).

Table 10.2 shows typical signalling in PMT and NIT used for the different OTA/OAD SSU alternatives:

Manufacturer	Model/version	Enhanced/ Simple without UNT	Service_ID	PMT Data_broadcast ID_descriptor	NIT Linkage_descript or
1	1	Simple	1	Manufacturer specific OUI with selector bytes.	Manufacturer specific OUI with selector bytes.
1	2	Simple	2	Manufacturer specific OUI with selector bytes.	Manufacturer specific OUI with selector bytes
1	3	Enhanced	3	DVB OUI	DVB OUI
2	1	Enhanced	3	DVB OUI	DVB OUI
3	1	Enhanced	3	DVB OUI	DVB OUI
4	1	Enhanced	4	Manufacturer specific OUI without selector bytes	Manufacturer specific OUI without selector bytes

Table 10.3 Example of signalling in the PMT and NIT

See more description in NorDig Unified IRD specification [116] and DVB SSU specification.

### 10.5.2 Update Notification Table (UNT)

For IRD using this OTA/OAD SSU method, the NorDig Operator **shall** use of the Compatibility\_descriptor, including hardware and software descriptors in accordance with ETSI TS 102 006 [28].

### 10.5.3 Data carriage over broadcast channel

Basic model for transmission of OTA/OAD SSU data file is that the IRD manufacturer provides a binary MPEG2 TS file to the NorDig Operator, who plays/cycles that MPEG2 TS file and inserts it in the broadcast.

The NorDig Operator supporting more advance delivering SSU data carriage (downloading) over the broadcast channel **shall** (1) support the DVB SSU standard update carousel data (update\_type 0x1 or 0x2) as specified in ETSI TS 102 006 [28].

In addition, the NorDig Operator should support proprietary IRD data format (update\_type 0x0). The definition of the proprietary format is up to the IRD manufacturer (In accordance with ETSI TS 102 006 [28]).

Note 1: Several system software updates, for a number of different IRDs may be transmitted as groups in this carousel. The DownloadServerInitiate message (DSI) will be used as the entry point in the carousel and may be shared by multiple manufactures.

One manufacturer can have multiple updates, each update in a separate group. It is assumed that all groups and modules can be transmitted on a shared elementary stream.

#### 10.5.3.1 Minimum bandwidth for SSU over broadcast channel

The NorDig Operator should target that SSU file are broadcast with a bitrate of at least 100 kbps (to ensure that the IRD does not time out due to slow download). It is recommended that a cycling period of the SSU file is kept to a reasonable short time (e.g., 10-30 min. or shorter).

#### 10.5.4 SSU Notifications (update\_type 0x4)

For IRD using this OTA/OAD SSU method, the NorDig Operator supporting SSU notification **shall** support the DVB SSU update\_type 0x4 using UNT, in accordance with the DVB-SSU specification [28]. A typical use case for SSU Notification is to reach all non-connected connectable IRDs via broadcast channel with information that new SSU software is available but the new SSU software size is too large to be distributed via broadcast channel and/or requires a higher bandwidth over broadcast channel than is available.

For reference, Manufacturers are recommended to:

- Pre-store SSU messages in their IRDs and messages should be in all available languages that the IRD supports,
- Mainly using the message\_index (in the enhanced\_message\_descriptor, see 12.7.10) to reference which pre-stored message to be displayed for the user,
- Minimise the broadcast text (in the enhanced\_message\_descriptor and/or message descriptor, see 12.7.10).

#### 10.5.5 CIP-CAM software updates

The descriptors for the SSU Notification in the UNT are specified in NorDig Unified IRD specification [106] Section 12.7.CIP-CAM software updates.

In the case of IRDs with DVB Common Interface Plus modules (CIP-CAM), the IRD is required to support to update the System Software on the CIP-CAM when such software is broadcast, in addition to the System Software on the IRD. In this case there could be two software images. The IRD is required to be able to identify whether there is an IRD update or CIP-CAM update.

Requirements for download functions in the CIP-CAM are defined in the CI Plus specification [64].

## **11 Performance**

Not Applicable for RoO.

## 12 Service Information

### 12.1 General

#### 12.1.1 General Requirements

The DVB Service Information (SI) and MPEG Programme Specific Information (PSI) has a very important part for the consumer IRD on how services are decoded and how to present the services. SI and PSI describes for the consumer IRDs among things;

- the network information, services that are available in the network, which services to install/display in service list(s), type of services, service description, where to find CA data for PayTV/scrambled services
- in combination with the IRD user preference setting to make appropriate selection of multiple components (e.g. automatically select audio among multiple audio streams/presentations or subtitling)
- event information for the services in order for the IRD to process and present in the EPG

The SI and PSI transmission **shall** (as much as possible) be compliant with DVB SI ETSI EN 300 468 [13], DVB SI Guidelines ETSI TR 101 211 [25], MPEG Systems and NorDig Unified IRD specification. Operators and Networks should avoid it but may sometimes need to go outside the DVB specification and recommendations if they find conflicts in DVB/MPEG specifications for their network and/or for compensating for legacy IRD misbehaviours.

The NorDig IRD specification has since start (y. 1999) required and still requires NorDig IRDs to ignore/skip the complete text string that is using DVB character tables that the IRD does not support and descriptors or other data structures that are currently undefined or are unknown. Introducing new additional PSI and SI data, for example for new type of services using new kind of codec supported only by the latest IRDs, is therefore possible but network/operator should take extra care and avoid disturbances within legacy IRDs (for example via pre-testing in testlab).

IRDs has limited amount of RAM memory that can be used for process and store SI data, often more than well enough for basic PSI and SI (NIT, SDT), but the transmitted EIT data can in some cases consume quite much memory in the IRD. DVB and MPEG defines the structure and sections for SI data in order for the IRD to filter out SI data. Network/operator should be aware that huge amount of EIT could lead to that e.g. the IRD prioritises and skips part of the data EIT and that the presented EPG in not “complete”.

It is not singularly defined in the NorDig IRD specification how an IRD shall detect changes in PSI/SI transmission, but it is a guideline to use and compare the ‘version id’ in the tables. Network/operator should therefore signalise changes in the PSI/SI tables via incrementing the version id in the tables.

#### 12.1.2 PSI/SI classification

See NorDig Unified IRD specification.

#### 12.1.3 Private data specifier value

The private data specifier shall be signalised when using NorDig defined SI for example the (NIT) NorDig logical channel descriptor or (SDT) Linkage descriptor with NorDig Simulcast replacement service.

#### 12.1.4 Service Types

NorDig has defined a subset of DVB Service types (DVB SI Specification, ETSI EN 300 468 [13], used in the Service descriptor within the SDT) that a NorDig IRD **shall** as minimum handle those listed in Table 12.1 below. The reason for signalling different service types for TV services in the transmission is for different generation and/or types of IRDs to filter out not supported services types.

In some networks there might be different generations of IRDs (e.g., older MPEG-4 only IRDs (i.e. NorDig basic IRDs) supporting only MPEG-2/H.262 and MPEG-4/AVC/H.264 based services and more modern HEVC IRDs supporting MPEG-2/H.262, MPEG-4/AVC/H.264 and HEVC/H.265 service types).

The network should therefore signalise appropriate service type for the services, so that the IRDs can filter out service types that it does not support and avoid presenting error messages of not supported codecs for the viewer. For services that are periodically is changing service format/codec over it broadcast hours (e.g. MPEG-4/AVC SD daytime and MPEG-4/AVC HD primetime/evenings), it is recommended to keep the service type static (e.g. as AVC/H.264 HDTV type).

Informative; NorDig IRDs should ignore service types that are not supported.

<b>Class of service</b> (description of service type)	<b>Service type (SDT)</b>	<b>Component descriptor (SDT)</b>	<b>NorDig IRD Support</b>	<b>Category type</b>	<b>NorDig IRD Priority</b>
<b>TV service</b> (mainly MPEG-2/H.262 based SDTV)	0x01	Ob Or	M	TV	5
<b>Radio service</b> (mainly MPEG-1 Layer II based)	0x02	Ob Or	M	Radio	2
<b>Teletext service</b>	0x03	Ob Or	M	others	
Advanced codec based <b>Radio service</b> (MPEG-4 HE-AAC, AC-3/E-AC-3, AC-4 (1))	0x0A	Ob Or	M	Radio	1
<b>Data broadcast service</b> (e.g. for SSU service) and HbbTV standalone services	0x0C	Ob Or	M	others	
AVC/H.264 based <b>SDTV service</b>	0x16	Ob Or	M	TV	4
AVC/H.264 based <b>HDTV service</b>	0x19	Ob Or	M	TV	3
HEVC/H.265 based TV service (up to UHD, SFR and SDR compatible, incl HDR/HLG10)	0x1F	Mb Mr (2)	M (1)	TV	2
HEVC/H.265 based TV service with PQ10 HDR (up to UHD, SFR/HFR)	0x20	Mb Mr (2)	M (1)	TV	1
Others	others		O	Others	lowest
M; Mandatory, R; (Highly) Recommended, O; Optional item to support, Alt; minimum one among several options. Priority; lower value refers to higher priority. Note 1: Mandatory for NorDig HEVC IRDs, optional for IRDs not supporting HEVC. Note 2: Used in addition to service_type to identify components' complexity for a service. See section 12.3.6 for mandatory types for the NorDig HEVC IRD.					

Table 12.1 Overview of service types, service category groups and priority between the service types.

*Informative: During migration period simulcasting of the content in (MPEG2) SDTV and in (MPEG4 AVC) HDTV may occur. Simulcasting may be under the same service (service\_id) or on separate services (separate service\_ids).*

*For service simulcasting on separate service\_ids a linkage 'NorDig Simulcast replacement service' (linkage type 0x82) will be broadcasted from the SDTV version pointing to the HDTV version of the same service, in order to help the IRD to know that these services are two versions of the "same" service/content.*

*The service types 'Advanced codec based Radio service' (0x0A), 'advanced codec based SDTV service' (0x16) and 'advanced codec based HDTV service' (0x19) will be used for services where the main component is an advanced codec stream. For TV services the main component is the video stream while for Radio services the main component is the audio stream. These service types will be used when it is not*

*desirable that an old MPEG-2 only IRD install and list a MPEG-4 service.*

*The service type 'digital TV service' (0x01) will be used for services including MPEG-2 video stream. It may also be used for service simulcasting MPEG-2 and MPEG-4 AVC video and for services only including MPEG-4 AVC video. All IRDs will install service type 'digital TV service' (0x01). This service type (0x01) may be used for a service that only includes MPEG-4 AVC video when it is desirable that an old MPEG2 only IRD installs and lists a service (even if old MPEG-2 only IRDs cannot decode the video, used for promotional purpose).*

*The logical channel number **shall**, as far as possible, be unique within each original network id for each service type category (TV, Radio and Others).*

#### 12.1.5 Service Categories

See NorDig Unified IRD specification.

#### 12.1.6 Used PSI/SI descriptors

The following sections identify the (P)SI tables transmitted in all transport streams.



Descriptor	Tag value	Tag extension value	NIT	BAT	SDT	EIT	TOT	CAT	PMT
audio_stream_descriptor	0x03	-	-	-	-	-	-	-	Mb
target_background_grid_descriptor	0x07	-	-	-	-	-	-	-	Ob
video_window_descriptor	0x08	-	-	-	-	-	-	-	Ob
CA_descriptor	0x09	-	-	-	-	-	-	Mb	Mb
ISO_639_language_descriptor	0x0A	-	-	-	-	-	-	-	Mb
Carousel_id_descriptor	0x13	-	-	-	-	-	-	-	Mb
Metadata_pointer_descriptor	0x25	-	Ob	-	Ob	-	-	-	-
Metadata_descriptor	0x26	-	-	-	-	-	-	-	Ob
[MPEG] Extension_descriptor (7)	0x3F	-	-	-	-	-	-	-	Ob
network_name_descriptor	0x40	-	Mb	-	-	-	-	-	-
service_list_descriptor	0x41	-	Mb	-	-	-	-	-	-
satellite_delivery_system_descriptor	0x43	-	Mb	-	-	-	-	-	-
cable_delivery_system_descriptor	0x44	-	Mb	-	-	-	-	-	-
service_descriptor	0x48	-	-	-	Mb	-	-	-	-
linkage_descriptor	0x4A	-	Mb	-	Mb	*	-	-	-
short_event_descriptor	0x4D	-	-	-	-	Mb	-	-	-
Extended_event_descriptor	0x4E	-	-	-	-	Mb	-	-	-
Component_descriptor	0x50	-	-	-	-	Ob	-	-	-
stream_identifier_descriptor	0x52	-	-	-	-	-	-	-	Ob
CA_identifier_descriptor	0x53	-	-	-	Ob	Ob	-	-	-
content_descriptor	0x54	-	-	-	-	Mb	-	-	-
Parental_rating_descriptor	0x55	-	-	-	-	Ob	-	-	-
teletext_descriptor	0x56	-	-	-	-	-	-	-	Mb
local_time_offset_descriptor	0x58	-	-	-	-	-	Mb	-	-
Subtitling_descriptor	0x59	-	-	-	-	-	-	-	Mb
Terrestrial_delivery_system_descriptor	0x5A	-	Mb	-	-	-	-	-	-
private_data_specifier_descriptor	0x5F	-	Mb	-	Mb	Mb	-	-	Mb
service_move_descriptor	0x60	-	-	-	-	-	-	-	Ob
Frequency_list_descriptor	0x62	-	Ob	-	-	-	-	-	-
data_broadcast_id_descriptor	0x66	-	-	-	-	-	-	-	Mb
AC-3_descriptor	0x6A	-	-	-	-	-	-	-	Mb
Application_signalling_descriptor	0x6F	-	-	-	-	-	-	-	Mb
Default_authority_descriptor	0x73	-	-	-	Mb	-	-	-	-
Related_content_descriptor (3)	0x74	-	-	-	-	-	-	-	Ob
Content_identifier_descriptor	0x76	-	-	-	-	Mb	-	-	-
S2_satellite_delivery_system_descriptor (2)	0x79	-	Mb	-	-	-	-	-	-
enhanced_AC-3_descriptor	0x7A	-	-	-	-	-	-	-	Mb
AAC_descriptor	0x7C	-	-	-	-	-	-	-	Mb
T2_delivery_system_descriptor	0x7F	0x04	mb	-	-	-	-	-	-
supplementary_audio_descriptor	0x7F	0x06	-	-	-	-	-	-	Mb
message_descriptor	0x7F	0x08	-	-	Ob	-	-	-	-
ac-4_descriptor	0x7F	0x15	-	-	-	-	-	-	Mb
S2X_satellite_delivery_system_descriptor	0x7F	0x19	mb	-	-	-	-	-	-
audio_preselection_descriptor	0x7F	0x19	-	-	-	-	-	-	Mb
TTML_subtitling_descriptor	0x7F	0x20	-	-	-	-	-	-	Mb
user defined	0x80-0xFE	-	-	-	-	-	-	-	-
NorDig private: Logical_channel_descriptor, v1	0x83	-	Mb	-	-	-	-	-	-
NorDig private: Logical_channel_descriptor, v2	0x87	-	Mb	-	-	-	-	-	-
CI_protection_descriptor	0xCE	-	-	-	ob	-	-	-	-
user defined	0xFE	-	-	-	-	-	-	-	-
Forbidden	0xFF	-	Fb	Fb	Fb	Fb	Fb	Fb	Fb

Table 12.2: Overview over minimum used descriptors in NorDig broadcast and receivers.

- <b>Descriptor not applicable or not yet used as minimum within NorDig</b>	
Mb	Mandatory to broadcast, always/all time
mb	Mandatory to broadcast if applicable, i.e. if certain criteria is met (e.g. if scrambling is used)
Ob	Optional to broadcast, but recommended (if applicable)
Fb	Forbidden to broadcast (may cause misinterpretation)
Mr	Mandatory to receive and interpret if broadcast
Or	Optional to receive and interpret (if broadcast)
Note 1:	Only mandatory for IRD with HbbTV capability
Note 2:	Descriptors carried in the NIT are not relevant for IRDs with IP-based Front-end, See Annex C. Delivery descriptors requirements depends of which tuning and demodulation the IRD supports, see table 12.7.
Note 3:	Only applicable for NorDig PVR IRDs only.
Note 4:	Only applicable for NorDig IRD-T2
Note 5:	Mandatory to receive from SDT-actual for IRDs that support use of CIP-CAMs, See section 9.2.
Note 6:	The value of component_type to be used within the component_descriptor <b>shall</b> be equal to the value of component_type held in the AC-3_descriptor or Enhanced_AC-3_descriptor or AAC_descriptor.
Note 7:	The DVB extension_descriptor is defined in DVB-SI (EN 300468) [13].
Comment:	
	Descriptors used for the UNT of the DVB SSU Enhanced profile are given in NorDig Unified IRD specification table 12.30
	Descriptors used for the RCT (only applicable for PVRs) are given in NorDig Unified IRD specification table 12.21

### 12.1.7 Character sets in text strings

See NorDig Unified IRD specification.

Each network/operator normally use one common character table within the transmission, suitable for its textual language(s) used in the PSI/SI.

### 12.1.8 Country and Language Codes within PSI/SI

**Country codes** inside DVB SI descriptors (e.g. local time offset descriptor) uses three-letter code (alpha-3) from the ISO 3166 specification (inserted as UPPER CASE/CAPITAL letters). NorDig Unified IRD spec has listed a subset of country codes used for NorDig members (other markets using NorDig specification may have additional or other country code(s)).

**Language codes** inside DVB SI descriptors (e.g. ISO639 language descriptor) uses three-letter code (alpha-3) from the ISO 639 **Error! Reference source not found.** specification (inserted as lower case/small letters). NorDig Unified IRD spec has listed a subset of language codes used for NorDig members (other markets using NorDig specification may have additional or other language code(s)). NorDig recommends to use terminological (ISO 639-2/T) codes in the transmission if possible (see note 1, unless for legacy IRDs reasons a network need to use bibliographic codes).

Informative: NorDig IRDs uses the Language Codes for following main purposes:

- (in PMT/services) selecting appropriate (audio, subtitling) stream/PID when multiple streams/PIDs are available for one service, all according to IRD's current user preference settings
- (in EIT) selecting appropriate languages for EPG text when multiple text languages are available inside EIT stream, all according to IRD's current user preference settings and
- to present information about services

**Language code** guideline: Language code should be set to what the broadcaster's main targeted language for its viewers. A guide could be the language of the service that does not translate the program audio

content from (via dubbing audio or via adding subtitling) or the main spoken language(s) of the viewers that the service target.

**Quasi-static in PMT:** It is generally recommended to keep the language code in the PMT quasi-static (fixed) over time, especially if there are multiple streams/PIDs with different languages available (otherwise viewers might have problem that their IRDs not selecting the desired language stream/PID compared to IRD's user preference settings). For PMT/services it is normally good to first ensure that IRD can make right stream/PID selection and secondly of what IRD present in GUI/EPG/info banner of the current service. (Use instead the language code in the EIT dynamic if it is of interest to inform viewers what specific language each program event has).

**IRD behaviour:** Good to know for the setting of language codes in the transmission: NorDig IRDs have different behaviours for audio and subtitling. For audio the IRD will always output an audio even if no audio's signalised language matches the IRD user preference settings (see NorDig IRD spec section 6.5.1). But for subtitling the IRD will only output/display a subtitling if one of the subtitling tracks' signalised language matches the IRD user preference settings (see NorDig IRD spec section 7.1.3).

**IRD language support:** The operator(s)/regulator(s) in charge for specifying the functionality of the IRD for a specific network and ensuring that the minimum requirements are met, may exclude some of the mandatory country and language codes listed in NorDig. Therefore, in some NorDig networks and some NorDig IRDs intended only for a specific network, might not support all country and Language codes defined in NorDig.

**'nar'/'narrative':** NorDig has defined the language code 'nar' as "narrative", that may be used for supplementary audio streams (Audio Description etc). This is mainly used in ISO 639 descriptor to prevent some older legacy IRDs selecting wrong audio stream/PID compared to IRD's user preference settings (especially for legacy IRDs which have difficulties in differentiate the audio type between normal, descriptive audio or spoken subtitling and when services has two audio with the same language; one for normal audio and one for supplementary/AD audio). A guide for the supplementary audio streams (when a network consists of many different legacy IRDs) is to set language in ISO639 descriptor to 'nar' as "narrative" but in Supplementary audio descriptor for same audio stream/PID set language code to language of the service. (See more in audio section).

**Example:** A Swedish TV service (targeting Swedish spoken viewers) which broadcast a mix of foreign/non-Swedish spoken program content and Swedish spoken program content in it schedule and so that the spoken language inside an audio stream/PID changes over time depending program content. During foreign/non-Swedish spoken program content, the broadcaster keeps the content's original audio language (no dubbing) and for those program events inserts translation to Swedish via subtitling. But for the broadcaster's own produced content, shorter interstitiales/promos between program events, commercial ads etc. are normally in Swedish spoken audio language. For such an example, even if the foreign/non-Swedish spoken program is broadcasted the big majority of time, the language code for the audio should be set to Swedish.

**Example:** A service that has two or more simultaneous audio streams/PIDs (fixed or dynamically), where one stream/PID always keeps content in the original spoken language and another stream/PID sometimes or always dub/change language to service targeted country's main language(s) (e.g. dubbing audio languages for children program events). For such an example, the first audio stream/PID can signalise language as "original" and the other audio stream/PID can signalise to the language used for dubbing.

Note 1: DVB SI specification (ETSI EN300 468 [13]) defines that three-letter language\_code to be used as specified by ISO 639-2 **Error! Reference source not found.**, but allows for using both the bibliographic (ISO 639-2/B) and the terminological (ISO 639-2/T) codes. For most of the languages in the ISO639-2 has same codes for both bibliographic (B) and the terminological (T), but for some (currently around 22 languages) the codes differ for bibliographic and the terminological (examples are French, German, Gaelic, Czech). According to Wikipedia, the bibliographic (B) codes "were included for

historical reasons because previous widely used bibliographic systems used language codes based on the English name for the language”.

#### 12.1.9 NorDig common EPG/Event metadata exchange format (informative)

The NorDig EPG/Event Metadata Exchange format specification covers EPG / Event programme information both for live and on demand content on all media platforms (broadcast TV, PC, mobile, Tablets, etc.) and various distribution networks (DTT, Sat, internet, etc.) and include rights managements. The NorDig EPG/Event metadata exchange format is based on the TV-Anytime specification (hereafter TVA), latest version, which supports NorDig requirement including rights management and cross platform distribution for both Live TV and On demand.

The NorDig common EPG/Event metadata exchange format is meant for professional B2B (business-to-business) use for all stakeholders in the distribution chain.

For more information see “NorDig Metadata Exchange format specification”, “NorDig TVA Guidelines Implementation package” and “NorDig TV-Anytime Genre list” (which includes translation to Nordic and Irish languages, and mapping to DVB Genre used in EIT).

#### 12.2 **Network Information Table (NIT)**

NIT shall be transmitted in each transport stream in the network.

Both NIT\_actual\_table\_id 0x40 (64) and NIT\_other table\_id 0x41 (65) shall be transmitted.

The NIT shall always be transmitted on PID 0x0010, with a recommended repetition rate of 8000 ms.

A network is defined as a number of transport streams that share the same value of Original Network ID (ONID) and same value of network ID, the NIT actual shall carry details of all transport streams in the current network as defined by the value of the network ID.

A single Frequency List Descriptor shall be carried in each Transport Stream loop of the NIT actual; each instance of the Frequency List Descriptor shall describe all frequencies on which this transport stream may be received.

A single (terrestrial) Delivery Descriptor shall be used in each Transport Stream Loop of the NIT actual; each instance of the (terrestrial) Delivery Descriptor shall describe the properties for this transport stream.

The Frequency List Descriptor defines the frequency on which the Transport Streams are broadcast.

A single logical Channel Number Descriptor shall be carried in each transport Stream loop of the NIT actual, the LCN Descriptor shall be used to describe the LCN and the availability of each service carried within this Transport Stream.

The Private Data Specifier Descriptor shall be carried in the NIT actual to specify private descriptors, such as the NorDig LCN.

## 12.2.1 The Network Information Table Descriptors

NIT descriptors	Cable IRD	Satellite IRD	Terrestrial IRD
Metadata_pointer_descriptor (3)	Optional	Optional	Optional
Network_name_descriptor	Mandatory	Mandatory	Mandatory
Service_list_descriptor	Mandatory	Mandatory	Mandatory
Satellite_delivery_system_descriptor	n/a	Mandatory	n/a
S2_satellite_delivery_system_descriptor	n/a	Mandatory	n/a
S2X_satellite_delivery_system_descriptor	n/a	Mandatory (4)	n/a
Cable_delivery_system_descriptor	Mandatory	n/a	n/a
Terrestrial_delivery_system_descriptor	n/a	n/a	Mandatory
T2_Terrestrial_delivery_system_descriptor (2)	n/a	n/a	Mandatory (2)
Linkage_descriptor	Mandatory	Mandatory	Mandatory
Private_data_specifier_descriptor	Mandatory	Mandatory	Mandatory
Frequency_list_descriptor	Optional	Optional	Mandatory
default_authority_descriptor (3)	Mandatory (3)	Mandatory (3)	Mandatory (3)
(NorDig) logical_channel_descriptor (Version 1)	Mandatory	Mandatory	Mandatory
(NorDig) logical_channel_descriptor (Version 2)	Mandatory	Mandatory	Mandatory

Table 12.3: NIT descriptors.

Note 1: The NIT is not used with NorDig IRDs with IP-based front-ends.

Note 2: Descriptor is signalled in the extension\_descriptor.

Note 3: NorDig PVR only.

Note 4: only mandatory for satellite NorDig HEVC IRDs that support DVB-S2X.

**Additional information about descriptors not explicit described in the NorDig Unified IRD specification** (this NorDig Rules of Operation follows the NorDig Unified IRD specification basic chapter layout and to avoid changing layout here following descriptors are listed here below without giving each descriptor its own subsection).

Network Name Descriptor:

A *network\_name\_descriptor* (0x40) **shall** be inserted for each NIT sub table.

Service list descriptor:

A *service\_list\_descriptor* (0x41) may be inserted for each transport stream defined in each NIT section. The *service\_list\_descriptor* could be applicable when the *NorDig logical channel descriptor* is not used. If used, then all services targeted for the network in a transport stream shall be listed in the *service\_list\_descriptor*. However, the NorDig IRDs use the SDT to build the service list. (The IRD expected behaviour of the service list descriptor and its content is not defined by NorDig Unified IRD specification **Error! Reference source not found.** and DVB SI guidelines **Error! Reference source not found.** is not especially precise. Unless a network has

defined IRD behaviour more exact, the service list descriptor may be omitted).

Satellite delivery system descriptor:

A *satellite\_delivery\_system\_descriptor* (0x43) shall be inserted for each transport stream in a satellite network. All transport streams in a network shall be defined in the appropriate NIT section.

Private data specifier descriptor:

A *private\_data\_specifier* with tag value(0x5F) shall be inserted in the secondary descriptor loop of the NIT. For NorDig Logical Channel Descriptor (LCN) V1 & V2 the *private\_data\_specifier\_value* shall be 0x00000029.

#### 12.2.2 Metadata Pointer Descriptor (NorDig PVR only, Broadcast Record Lists)

See NorDig Unified IRD specification.

#### 12.2.3 Cable Delivery System Descriptor

A *cable\_delivery\_system\_descriptor* (0x44) shall be inserted for each transport stream in a cable network. All transport streams in a network shall be defined in the appropriate NIT section.

#### 12.2.4 Terrestrial Delivery System Descriptor

A *terrestrial\_delivery\_system\_descriptor* (0x5A) shall be inserted for each transport stream in a terrestrial network. All transport streams in a network shall be defined in the appropriate NIT section.

Operators can broadcast the same transport stream in the same network using different modulation parameter settings. This allows for optimisation of the network coverage in frequency planning involving SFN and MFN combination networks.

The modulation parameters carried in the *terrestrial\_network\_descriptor* are recommended to be the one applicable to the majority of IRDs in that network.

#### 12.2.5 T2 Delivery System Descriptor

Operators can broadcast the same transport stream in the same network using different system parameter settings, reflected in a different *T2\_system\_id*. This allows for optimisation of the network coverage in frequency planning involving SFN and MFN combination networks.

#### 12.2.6 Linkage Descriptor

The following subset of *linkage\_type* values are defined by NorDig and may be used in NorDig networks, when used inside the NIT

- 0x01, linkage to a service that contain information about the network
- 0x02, linkage to an EPG service
- 0x04, linkage to transport stream which carries EIT schedule information for all of the services in the network (i.e. “barker channel” service)
- 0x09, linkage to DVB System Software Update service (SSU), see section 10. The linkage descriptor for SSU shall be inserted into the first NIT descriptor loop (NIT’s common descriptor loop) and shall only be broadcast when the SSU is available. Private Data within the descriptor will indicate originating manufacturer of the software or the generic “DVB SSU”

### 12.2.7 Frequency List Descriptor

A *frequency\_list\_descriptor* (0x62) may be inserted in the secondary descriptor loop of the NIT. The descriptor should list all frequencies that the transport stream employed in the network uses. A guide can be to limit the frequencies to all frequencies that the transport stream has within that *network\_id*. A transport stream may be divided into different regional versions where some of the service differs from region-to-region, i.e., regional/local services. Typically meaning same *transport\_stream\_id* but different *network\_id* where some services differ from one version of the transport stream to the other (regional/local broadcast, e.g., could be a national service that in different regions has different regional program and/or ad insertion).

If there are more than one frequency employed in the network, the *other\_frequency\_flag* in the *terrestrial\_system\_descriptor* shall be set to “1” indicating that other frequencies are in use.

Within a broadcaster’s service area there will be many transmitters operating on different frequencies and bands, inevitably there will be overlaps between main transmitters and daughter relay stations. Inclusion of this descriptor is optional, but if it is present, then the list of frequencies shall be complete. Broadcasters shall list additional frequencies for the same service multiplex in the *frequency\_list\_descriptor* of the secondary loop of the Network Information Table (NIT). As a consequence, the IRD may discriminate between services and LCN intentionally duplicated. Services which are duplicated but of a lower receiving quality may be discarded by the IRD in favour of best quality service by examining the frequency list descriptor of the NIT.

A typical network information table tree is indicated below in Figure 12.1:

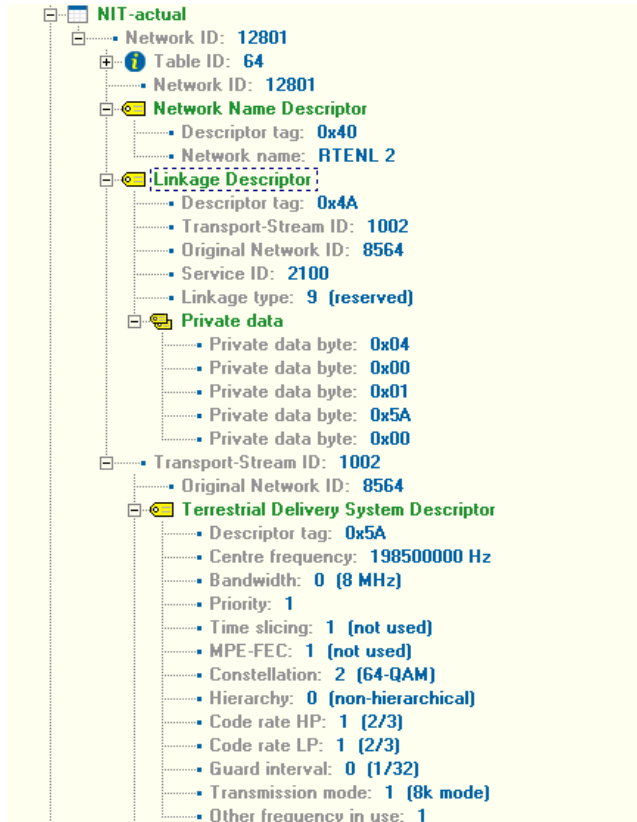

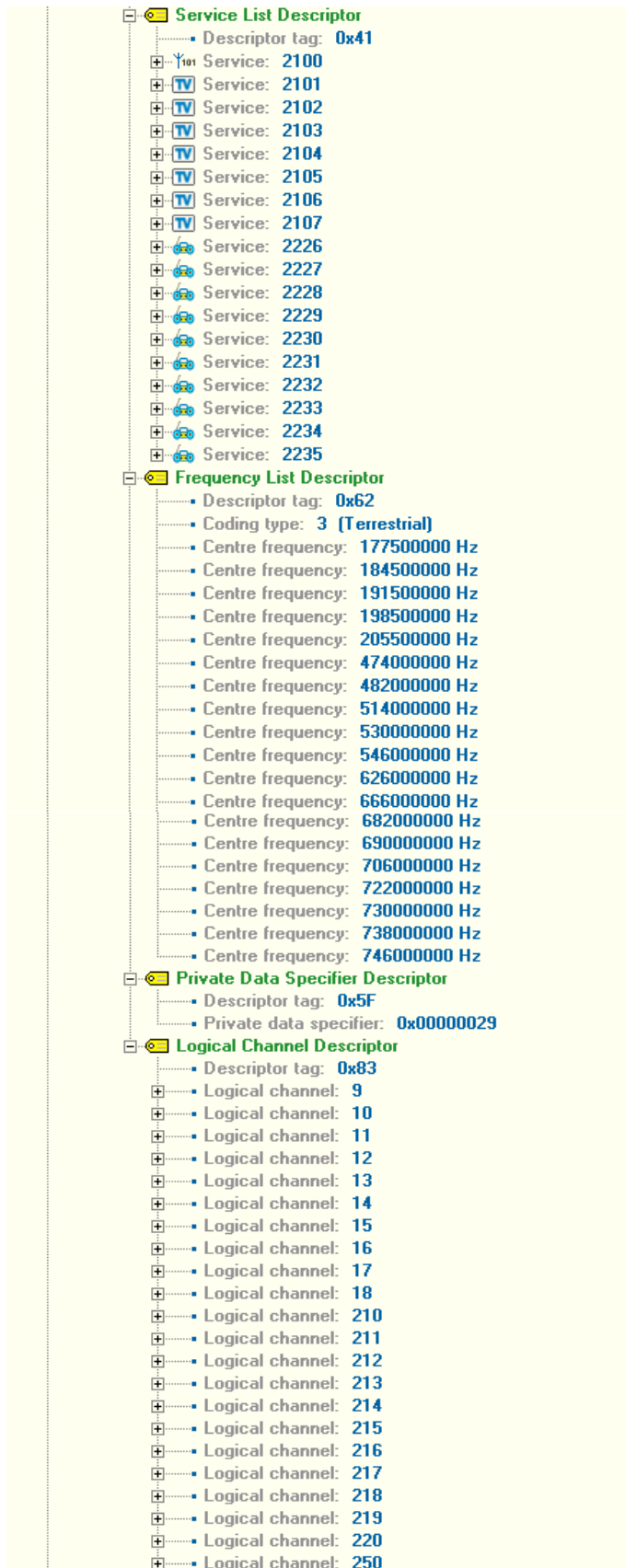

Figure 12.1: Typical Network Information Table structure.



### 12.2.8 Default authority descriptor (in NIT) (NorDig PVR only)

See NorDig Unified IRD specification.

### 12.2.9 NorDig private; Logical\_Channel\_descriptor (LCD)

#### 12.2.9.1 General

The NorDig logical\_channel\_descriptor (LCD) helps the consumer NorDig IRDs to:

- Pre-sort all services within the network inside the consumer IRDs' service list after channel installation in a relative order that is set by the transmission defined by the operator/broadcaster/administrator of the network. All services are assigned unique a logical channel number that viewers may use to access the services via e.g. keying that number on the remote control. (Then most IRDs may typically allow users/viewers to create additional service lists and sort TV & Radio services according to the users'/viewers' own preferred order).
- Hide services not intended to be listed/displayed for viewers in the IRD's service list (i.e. background services). Example of Background/hided services could be services carrying new System Software Update streams within broadcast network to IRDs, and services that have been moved to another transport streams but remain a shorter period in parallel within it old location to for example help with the transition.

In order to get all services listed in a defined order, then all services need to be listed in the LCD.

The NorDig *logical\_channel\_descriptor* is a privately defined descriptor intended for use in NorDig networks, it shall be inserted in the second descriptor loop of the NIT.

The *logical\_channel\_descriptor* should list all services contained within the transport stream and shall specify the logical channel number (LCN) that is assigned to each of those services. All services NOT listed in any *logical\_channel\_descriptor* are required to be listed and displayed in the NorDig IRD's service list (but the IRD shall list these services last in the service list and in a mutual order defined by the IRD manufacturer i.e. not a defined order among these unlisted services and different IRDs may have different ordering algorithms).

**Private data specifier:** Other IRD specifications, like DTG D-book and Digital Europe E-book, has also defined their logical channel descriptors, often using the same descriptor tag (0x83). However, some of the others has slightly other syntax and slightly other IRD behaviour, for example has NorDig has defined a flag to hide or make services visible in IRD's compiled service list. Therefore, it is important to include the *private data specifier descriptor* (with NorDig's value, i.e. 0x0000029) in front of the NorDig *logical\_channel\_descriptor* in the descriptor loop. This will inform the IRDs of which specification the *logical\_channel\_descriptor* is using).

*Comment: The wording 'Channel List' refers here to the transmission side and this LCD is used to transmit a Channel List, while the 'Service List' refers to the IRD's stored list of services. The IRD uses the transmitted LCD Channel List data amongst other SI data to create update and sort services of its own default Service List).*

**Note:** The list should be as neutral as possible relative to the different competitive broadcasters/services within the network, target to suit the majority of viewers and on each market relate to the commonly used relative orders (a guide could for example be that a countries or networks biggest TV services are assigned the low/one-digit numbers and if possible, to service logical number, e.g. service SVT1 to LCN 1, service TV3 to LCN 3, etc).

#### 12.2.9.2 NorDig Logical Channel Descriptor (version 1) syntax

See Syntax for NorDig Logical Channel descriptor (version 1) in NorDig Unified IRD specification. NorDig Logical Channel descriptor version 1 only allows for one single logical channel list for the Network i.e. one service shall only be assigned to one logical channel number and visible flag value. (Version 2 allows for multiple lists).

The following gives extra guidelines for the transmission:

**visible\_service\_flag:** ‘1’/‘true’ (visible) service will be visible and listed in consumer IRDs, ‘0’/‘false’ (non-visible) service will not be displayed for viewer in IRD service list. Guidelines is to set to visible (‘1’/‘true’) for all normal TV & Radio services that are intended to be visible and selectable for viewers. Set to non-visible (‘0’/‘false’) for “background” services like SSU and other data services etc. Non-visible (‘0’/‘false’) can also be used for services that is moved from one service\_id to a new one, where the new location/service id is signalled as visible and old location/service id as non-visible.

**logical\_channel\_number:** The broadcaster preference for ordering services. The logical channel numbers (LCN) is intended to be assigned in combination with the service type category and **shall** be grouped into the three service type categories; TV, Radio and Others/data services as specified in NorDig Unified IRD specification section 12.1.5.

Each Network/Broadcaster **shall**, as far as possible, for all services which are defined as unique on the network, assign unique LCN within his original\_network\_id and within each service type category (TV, Radio and Others).

Services which differ only in regional interstitials (local programming or advertising) is highly recommended to be assigned the same LCN.

This means to achieve proper behaviour at consumer IRDs that (for ‘visible’ services with LCN  $\neq$  0):

- The same LCN **shall** not be assigned to two different services of same service\_type.
- The same LCN **shall** not be assigned to two different services which are of same service category (e.g TV) but on different service types (e.g. service types of TV category: 0x01, 0x16, 0x19, 0x1F or 0x20).
- LCN should be uniquely assigned over all service categories/service types (TV, Radio and Data services) in the network. LCN may be reused between TV category and Radio category of services, BUT it is recommended to not reuse the LCN between the service categories (some IRDs create separate list for TV and Radio category, while other IRDs creates a common list for TV and Radio).
- The same LCN **shall** be assigned to all regional services of a national service that is split up into regional versions (with different service\_id for each region), that most of its time broadcast same (national) program content in all regions, but part of the time inserts different regional content into regions.
- The same LCN may be used for when same service is simulcasted in two or more formats/codecs on different service\_ids (e.g. on one version in MPEG-4/AVC SD 0x16 and on another version in HEVC FullHD 0x20 format). NorDig IRDs will however prioritise LCN for the service with higher service\_type value and list other lower prioritised services with same LCN last in the list.
- For Simulcast same service in two (or more) formats/codecs, the *NorDig Simulcast replacement service* linkage (in SDT) may be used in addition. Then older IRDs not supporting the latest format/codec only displays the service with the “old” format/codec and hides the service using format/codec not supported by that IRD, while newer IRDs (e.g. HEVC IRDs) only displays the service/version with the “new” format/codec and hides the service/version using “old” format/codecs (see section 12.3.4).
- (All ‘non-visible’ services/background services shall of course use the same LCN = 0).

The logical\_channel\_number use is defined in table below.

visible service flag	Logical channel number (decimal value)	Description
0	0	Used for “non-visible” services that NorDig IRD shall hide/not present in their service list for the viewers. Service not suitable for selection by the user. For example, the value zero may be used for data services only intended for selection from interactive applications or for firmware download services etc.
0	1 – 16383	Reserved for future use (should not be used)
1	0	Reserved for future use (should not be used)
1	1 – 9999	Used for “visible” services that NorDig IRD will present in their service list for the viewers. Service will be displayed in service list and EPG/ESG. Accessible via P+/- keys or from numeric keys (same value as decimal value of logical_channel_number)
1	> 9999	Reserved for future use (should not be used)

Table 12.4: Logical\_channel\_number allocation (LCD v1).

Note: This older version of the NorDig Logical Channel Descriptor is in some NorDig Networks replaced by the newer version 2 below.

### 12.2.9.3 NorDig private; Logical Channel Descriptor (version 2) syntax

See Syntax for NorDig Logical Channel descriptor (version 2) in NorDig Unified IRD specification.

NorDig Logical Channel Descriptor Version 2 allows for multiple lists. Typically use cases for version 2 is satellite transmission covering and targeting multiple countries where each country their own list. (Version 1 only allows for one single logical channel list for the Network).

The following gives extra guidelines for the transmission:

If multiple channel list is broadcasted/transmitted: NorDig IRDs as a minimum only store one of the logical channel lists (some IRDs might store all/several of the broadcasted lists). The IRD typically let the user decide during the installation phase which one of the received broadcasted channel lists that shall be used by the IRD and then the IRD may/typically skip the other lists (i.e. user/viewer may typically need to make a re-installation of the IRD to change channel list). The IRD is expected to only use one of the lists at the time and not to combine several lists.

This means that each channel list needs to be complete with all services intended for that list/area/country (including non-visible services), i.e. it is up to the broadcaster/operator/network to ensure that all intended services are included in all lists.

**channel\_list\_name\_length/char:** Maximal length is 23 bytes for the channel\_list\_name text string.

**visible\_service\_flag:** See guidelines for NorDig Logical Channel descriptor version 1 above.

**logical\_channel\_number:** See guidelines for NorDig Logical Channel descriptor version 1 above (observe that version 1 has four digits (LCN between 1-9999), while version 2 has only three digits (LCN between 1-999)).

It could for example be that some services is only applicable for one of the lists/areas/countries and should not be listed/displayed in IRDs located in other areas/countries, this service shall be listed in all lists (in the intended area/country set as 'visible' with a LCN  $\diamond$  0 and in the other areas/countries set as 'non-visible' and the LCN = 0).

#### 12.2.9.4 Handling of multiple Channel lists from same network (LCD v2 only)

See NorDig Unified IRD specification.

#### 12.2.9.5 Sorting of services inside a Channel list

See NorDig Unified IRD specification.

#### 12.2.9.6 Conflict handling of Logical\_channel\_number

See NorDig Unified IRD specification.

#### 12.2.9.7 NorDig LCD simultaneous version 1 and version 2 transmissions

NorDig has defined two version of the LCD (version 1 and version 2). Version 2 allows for multiple lists and typically use cases is for (satellite) transmission covering and targeting multiple countries where each country has their own list.

The network should normally select only one of the LCD versions to broadcast. For some Networks which has some legacy IRDs not supporting LCD v2, it might be necessary to broadcast both v1 and v2. When broadcasting both LCD version 1 and version 2 within one Original Network ID, the NorDig IRD supporting both versions will only sort according to the version 2 (i.e. NorDig LCD version 2 has higher priority).

#### 12.2.9.8 Reception of multiple (DTT) networks and NorDig LCD

See NorDig Unified IRD specification.

*Informative: Some consumer IRDs might be located in areas/situations so that they are able to receive DVB signals from multiple original networks (original\_network\_ids), for examples DTT/terrestrial viewers living close to a neighbouring country. For NorDig IRDs that receive DVB signals from multiple original networks, they will make one of the original networks as its "primary network" and the other received original networks are referred to as "secondary network(s)". It is typical that the "primary network" is selected to match viewers preferred home network/country. NorDig IRDs will first sort/list all services from one original network (its "primary network") according to that LCD, before sorting/listing the next original network ("secondary network") last in the IRD's service list. This means that NorDig IRD will not mix services from different original networks in the service list or use empty gaps in the "primary network" list to fill with services from "secondary network", and instead lists them after each other's.*

#### 12.2.9.9 Guidelines of number of services to be handled (Informative)

Informative about IRDs: It is recommended that NorDig IRD with terrestrial front-end are able to handle up to 400 services identities during installation mode and 200 services. It is recommended that NorDig IRD with satellite, cable and IP front-end are able to handle up to 600 services identities during installation mode and 400 services afterwards

## 12.2.9.10 Examples of Logical Channel descriptor

## 12.2.9.10.1 Example of Logical\_Channel\_descriptor (LCD) (version 1)

The table below illustrates an example of broadcast and services and mainly includes different complex combinations that an IRD might receive (example for a terrestrial network, but other networks are similar). The service name is not included in this example (but is of course included in real cases). The abbreviations are defined as: SID; service\_id, ONID; original\_network\_id; TSID; transport\_stream\_id, NID; network\_id, VSF; visible\_service\_flag, LCN; logical\_channel\_number.

ONID	TSID	SID	NID	VSF	LCN	Service type	Comment
100	10	100	101	1	10	0x01 (TV)	SD service with linkage to NorDig Simulcast replacement service at SID 140
100	10	110	101	1	11	0x01 (TV)	No logical_channel_descr attached to this service same service but with lower reception quality than NID 102 below
100	10	90	101	-	-	0x01 (TV)	
100	20	120	101	1	23	0x01 (TV)	
100	20	120	102	1	23	0x01 (TV)	same service from an other transmitter point with better reception quality than NID 101
100	20	200	101	1	23	0x02 (Radio)	Radio service
100	20	210	101	1	25	0x0A (Radio)	Radio service (adv codec)
100	20	130	101	1	24	0x01 (TV)	HD service (takes LCN 10 as simulcast of 100 10 100)
100	30	140	101	1	10	0x19 (HDTV)	
100	30	150	101	1	11	0x19 (HDTV)	HD service (no simulcast, only prio to LCN 11 due to its service_type)
100	30	160	101	1	12	0x19 (HDTV)	HD service with linkage to NorDig Simulcast replacement service at SID 170
100	30	170	101	1	12	0x1F (UHDTV)	UHD service (takes LCN 12 as simulcast of 100 30 160)
100	10	500	101	0	0	0x0C (Data)	E.g. SSU/Bootloader or EPG service
<b>200</b>	10	100	200	1	10	0x01 (TV)	Other network provider

Table 12.5: Example of broadcast of SI and services using NorDig logical channel descriptor version 1.

From above example, the tables below show how NorDig IRDs would sort these services into the IRD's Service List. The first table below is for NorDig IRDs that create two service lists, one for TV and one for Radio services and the second table below for NorDig IRDs that create one single service list for both TV and Radio services (both alternatives are allowed in NorDig. Operator/Network may have additional requirements). The services list displayed for the viewer, will typically be the number (LCN) and the service\_name.

**NorDig IRD, service list installation example (IRD with separate lists for TV and radio)**

TV service list					Radio service list				
Number	ONID	TSID	SID	NID	Number	ONID	TSID	SID	NID
10	100	30	140	101	23	100	20	200	101
11	100	30	150	101	25	100	20	210	101
12	100	30	170 (1)	101					
23	100	20	120	102					
24	100	20	130	101					
25	100	10	110	101					
26	100	10	90	101					
27	200	10	100	200					

Note 1: NorDig HEVC IRDs will store SID 170, all other IRDs will store SID 160.

Table 12.6: NorDig IRD service list example using LCD v1 (IRD with separate lists for TV and radio).

**NorDig IRD with a common service list for TV and Radio**

Service list				
Number	ONID	TSID	SID	NID
10	100	30	140	101
11	100	30	150	101
12	100	30	170 (1)	101
23	100	20	120	102
24	100	20	130	101
25	100	10	110	101
26	100	10	90	101
27	100	20	200	101
28	100	20	210	101
29	200	10	100	200

Note 1: NorDig HEVC IRDs will store SID 170, all other IRDs will store SID 160.

Table 12.7: NorDig IRD with a common service list example using LCD v1.

The service [ONID, TSID, SID] = 100, 20, 120 is listed only once (even though that the service is transmitted twice). This because the IRD in this terrestrial network example above has a stronger and a better reception (quality) of the TS where service [ONID, TSID, SID, NID] = 100, 20, 120, 102 belongs to, than for the TS where the service [ONID, TSID, SID, NID] = 100, 20, 120, 101 belongs to.

12.2.9.10.2 Example of Logical\_Channel\_descriptor (LCD) (version 2)

Table below illustrates an example of LCD v2 broadcast and services and mainly includes different complex combinations that an IRD might receive (example for a terrestrial network, but other networks are similar). The service name is not included in this example (but is of course included in real cases). The abbreviations are defined as: SID; service\_id, ONID; original\_network\_id; TSID; transport\_stream\_id, NID; network\_id, VSF; visible\_service\_flag, LCN; logical\_channel\_number, CLID; Channel\_list\_id,.

CLID	ONID	TSID	SID	NID	VSF	LCN	Service type	Comment
1	100	10	100	101	1	10	0x01 (TV)	SD service with linkage to NorDig Simulcast replacement service at SID 140
1	<b>200</b>	10	100	200	1	10	0x01 (TV)	Other network provider and other combination channel_list_id, ONID
1	100	10	110	101	1	11	0x01 (TV)	
-	100	10	90	101	-	-	0x01 (TV)	No logical_channel_descr attached to this service
1	100	20	120	101	1	23	0x01 (TV)	Same service but with lower reception quality than NID 102 below
1	100	20	120	<b>102</b>	1	23	0x01 (TV)	same service from an other transmitter point with better reception quality than NID 101
1	100	20	200	101	1	23	<b>0x02</b> (Radio)	Radio service
1	100	20	210	101	1	25	<b>0x0A</b> (Radio)	Radio service (adv codec)
1	100	20	130	101	1	24	0x01 (TV)	
1	100	30	140	101	1	10	0x19 (HDTV)	HD service (takes LCN 10 as simulcast of 100 10 100)
1	100	30	150	101	1	11	0x19 (HDTV)	HD service (no simulcast, only prio to LCN 11 due to its service_type)
1	100	30	160	101	1	12	0x19 (HDTV)	HD service with linkage to NorDig Simulcast replacement service at SID 170
1	100	30	170	101	1	12	0x1F (UHDTV)	UHD service (takes LCN 12 as simulcast of 100 30 160)
1	100	10	500	101	0	0	0x0C (Data)	E.g. SSU/Bootloader or EPG service
2	100	10	100	101	1	20	0x01 (TV)	SD service that in SDT incl Linkage to NorDig Simulcast replacement service at SID 140
2	100	10	110	101	1	6	0x01 (TV)	
2	100	20	120	101	1	5	0x01 (TV)	
2	100	20	130	101	0	0	0x01 (TV)	Service not intended to be listed in CLID 2
2	100	30	140	101	1	20	0x19 (HDTV)	HD Simulcast service
2	100	30	150	101	1	6	0x19 (HDTV)	HD service (no simulcast, only prio to LCN 6 due to its service_type)
2	100	30	160	101	1	12	0x19 (HDTV)	HD service with linkage to NorDig Simulcast replacement service at SID 170
2	100	30	170	101	1	12	0x1F (UHDTV)	UHD service (takes LCN 12 as simulcast of 100 30 160)
2	100	20	200	101	1	13	0x02 (Radio)	Radio service
2	100	20	210	101	1	12	0x0A (Radio)	Radio service (adv codec)
2	100	10	500	101	0	0	0x0C (Data)	E.g. SSU/Bootloader or EPG service

Table 12.8: Example of broadcast of SI and services, LCN Version 2.

From above example, the tables below show how NorDig IRDs would sort these services into the IRD's Service List. The first table below is for NorDig IRDs which create two service lists (one for TV and one for Radio services) but the user has selected to use channel list CLID 1, and the second table below is for NorDig IRDs which create two service lists (one for TV and one for Radio services) but user has selected to use channel list CLID 2. The service list displayed for the viewer, will typically be the number (LCN) and the service\_name.

**NorDig IRD, service list when selected CLID 1**

TV service list					Radio service list				
Number	ONID	TSID	SID	NID	Number	ONID	TSID	SID	NID
10	100	30	140	101	23	100	20	200	101
11	100	30	150	101	25	100	20	210	101
12	100	30	170 (1)	101					
23	100	20	120	102					
24	100	20	130	101					
25	100	10	110	101					
26	100	10	90	101					
27	200	10	100	200					

**NorDig IRD, service list when selected CLID 2**

TV service list					Radio service list				
Number	ONID	TSID	SID	NID	Number	ONID	TSID	SID	NID
5	100	20	120	101	12	100	20	210	101
6	100	30	150	101	13	100	20	200	101
12	100	30	170 (1)	101					
20	100	30	140	101					
21	100	10	110	101					
22	100	10	90	101					
23	200	10	100	200					

Note 1: NorDig HEVC IRDs will store SID 170, all other IRDs will store SID 160.

Table 12.9: NorDig IRD service list example using LCD v2.

The service [ONID, TSID, SID] = 100, 20, 120 is listed only once (even though that service is transmitted twice). This due to that the terrestrial IRD in this example above has a stronger and a better reception (quality) of the TS where service [ONID, TSID, SID, NID] = 100, 20, 120, 102 belongs to, than for the TS where the service [ONID, TSID, SID, NID] = 100, 20, 120, 101 belongs to.

### 12.3 Services Description Table (SDT)

SDT\_actual table (0x42) is mandatory for each transport stream in the network. The SDT shall describe all services within the multiplex, it shall change when any of the services within the multiplex change status.

It is recommended that IRDs use the SDT\_actual to determine services that may be included in the channel list rather than the service\_list\_descriptor in (0x41) the NIT.

All sections within the SDT\_actual\_table shall be transmitted every 1000 ms.

Transmission of SDT\_other is recommended. But it can be difficult to use SDT\_other in some terrestrial network where transport streams are regionally divided (regional/local services), where the same transport stream (when using the same transport stream id) in different regions where part of the services are the same (same service\_id) and some services differs (i.e. regional/local services with different service\_ids). For such cases SDT\_other should be omitted in the transmission (this is to avoid misbehaviour for IRDs receiving signals from multiple regions). If used, then the SDT\_other (0x46) shall describe all other services carried on transport streams across the same network, it is recommended that IRD s rely upon SDT\_actual to determine which services to be included in the channel list (in combination with the NorDig channel list descriptor if that is used) and may also use the SDT\_other.

All sections of the SDT\_other should be transmitted every 10000 ms.

The EIT\_present\_following\_flag and the EIT\_schedule\_flag fields inside the SDT should match the transmission of the corresponding EIT subtables.



For each standard service the running status shall be set to 4 (running) and for each time shifted service (NVOD) the running status shall be set to 0 (undefined) as per ETSI EN 300 468 **Error! Reference source not found.**

### 12.3.1 The Services Descriptor Table Descriptors

SDT descriptors
metadata_pointer_descriptor (1)
service_descriptor
CA_identifier_descriptor
component_descriptor
linkage_descriptor
service_identifier_descriptor
default_authority_descriptor (1)
CI_protection_descriptor (2)
message_descriptor

Table 12.10: SDT descriptors.

Note 1: Mandatory for NorDig PVR IRD.

Note 2: Mandatory for NorDig IRDs that support use of CIP-CAMs, see section 9.2.

**Additional information about descriptors not explicitly described in the NorDig Unified IRD specification** (this NorDig Rules of Operation follows the NorDig Unified IRD specification basic chapter layout and to avoid change layout, the following descriptors are listed here below without giving each descriptor its own subsection).

service\_availability\_descriptor:

A *service\_availability\_descriptor* (0x72) shall be inserted when local services are not present across the whole network, the descriptor shall reference the service list against the services which are available for the IRD to decode.

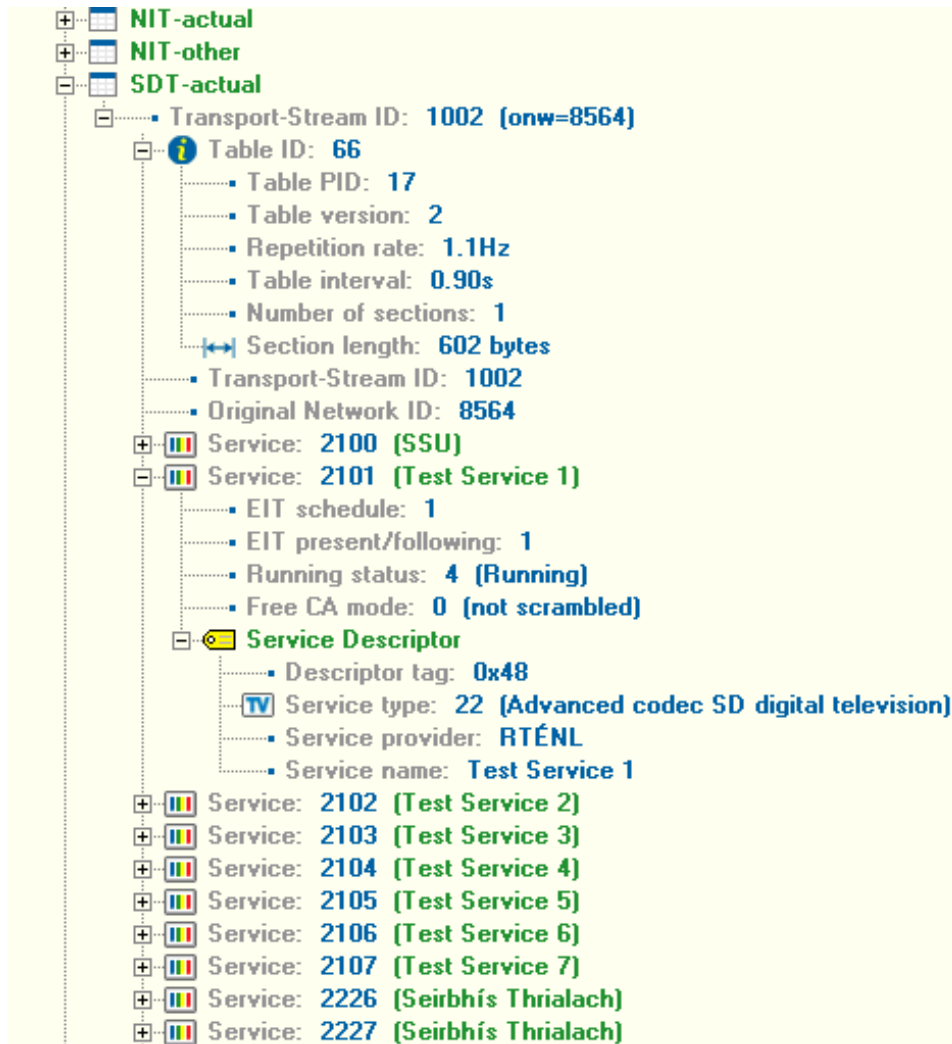

Figure 12.2: Typical Service Descriptor Table.

### 12.3.2 Metadata Pointer Descriptor (NorDig PVR only, Broadcast Lists)

See NorDig Unified IRD specification.

### 12.3.3 Service Descriptor

A *service\_descriptor* (0x48) shall be inserted for each service defined in the SDT. The *service\_descriptor* provides the name of the service and the service provider in text format together with the *service\_type*.

Service types available for use on NorDig DVB networks are listed in section 12.1.4 Table 12.1 above.

### 12.3.4 CA Identifier Descriptor

A *CA\_identifier\_descriptor* shall be inserted within the SDT as mandatory whenever at least one service component is scrambled. The aim of this descriptor is to prevent scrambled services being displayed in service lists by FTA receivers.

### 12.3.5 Linkage Descriptor

The following subsets of *linkage\_type* values are defined by NorDig and may be used in NorDig networks when used inside the SDT:

- 0x05, linkage to a service replacement service. When present, it is intended that the NorDig IRD should automatically switch to the replacement service if the 'running\_status' is set to "1" (not running), and if the NorDig IRD are able to receive the SDT containing the original service during the replacement, also switch back when 'running\_status' is set to "4" (running).
- 0x82, NorDig Simulcast replacement service, linkage from one TV based service to another TV replacement service with the same content, typical usage is to hide/not include the "old" version of the service and only list the "new" version in the IRD's service list. For example, it may be used during simulcasting of a service in both an (MPEG2/H.262) SDTV and an (AVC/H.264) HDTV version on separate service id's with the same content within the same original network id, or during simulcasting of an (AVC/H.264) HDTV and an (HEVC/H.265) UHD TV version with the same content. The linkage shall be included in the SDT for the "old" TV service that is intended to be replaced (hidden) and pointing to the "new" replacement service. Whenever it is used, it will be used quasi-static.
  - Informative about NorDig IRDs behaviour for 0x82 linkage to NorDig Simulcast replacement service:
  - For NorDig IRDs that are able to receive both the "old" TV service that is intended to be replaced (hidden) and the "new" replacement service, they will only include the "new" replacement TV version/(service) of the two services within its TV service list. The "old" TV service that is intended to be replaced (hidden) may be omitted or hidden at the end of the list, dependant of IRD implementation. The method is intended to be service type independent (1).
  - If no 'NorDig Simulcast replacement service' linkage is included, both services will be listed in the IRDs service list. If only the "old" TV service that is intended to be replaced (hidden) is possible to receive and decode while the new replacing service is not (due to e.g., reception problems or codec/service type limitations), then then NorDig IRD will include and display the "old" TV service that is intended to be replaced in the service list even if it carries the linkage 'NorDig simulcast replacement service'.

Note: Broadcasters should not use the 0x82 linkage replacement from a higher service\_type value (e.g. AVC/H.264) point to a replacement service with a lower service\_type value (e.g. MPEG-2/H.262).

#### 12.3.6 Default authority descriptor (in SDT) (NorDig PVR only)

A *default\_authority\_descriptor* (0x73) shall be inserted within the SDT to more efficiently manage the EIT CRID data necessary to support PVR functionality on the network; every service on the network shall be allocated a descriptor.

#### 12.3.7 (SDT) Component Descriptor

Used mainly for HEVC service types. For more information see, NorDig Unified IRD specification.

### 12.4 **Event Information Table**

#### 12.4.1 General

The IRD only uses EIT data for presenting program guide information to the viewers (ESG/EPG) and is used for controlling service recordings within the IRD (PVR). EIT data is not used for basic service decoding but with one exception, which is parental rating blocking in the IRD (triggered by the parental rating descriptor).

<b>EIT tables</b>	<b>Program event information of</b>	<b>Target repetition</b> (Examples for a network w 40-100 services & 7-days EPG) <b>Content amount</b>
EIT p/f actual, table_id 0x4E	Present & following (now & next) events of services within actual transport stream	1.5 – 3 s (DVB rec. 2s)  Long/full text description/length and “all” component descriptions
EIT p/f other, table_id 0x4F	Present & following (now & next) events of services in other transport streams of the network	10 – 20 s (DVB rec. 10-20s)  Long/full text description/length and “all” component descriptions
EIT sch actual, table_id 0x50 to 0x5F	Schedule events of services within actual transport stream (longer schedule, days, typical one week)..	30 – 120 s (DVB rec. 10-30s)  Full or reduced text description/length and reduced amount of component descriptions
EIT sch other, table_id 0x60 to 0x6F	Schedule events of in other transport streams of the network (longer schedule, days, typical one week)	100 – 400 s (DVB rec. sat 10-30s, ter 30-300s)  Full or reduced text description/length and reduced amount of component descriptions
General	EIT schedule is split up into different table_ids, each table_id can contain information about up to four days of schedule. E.g. for 7 days of EIT schedule, then table_id 0x50 shall contain the first four days of schedule and table 0x51 the last three days of schedule.	To maximise the use of the bandwidth allocated for EIT, it can be more efficient to use a fixed bitrate for the whole EIT and let the repetition rates vary over time depending on the present amount of total EIT data (e.g. EIT sch tables and sections with more present information (e.g. “today”) could have faster repetition rates than EIT schedule containing more future events (e.g. day 5-7).  A recommendation could be to avoid extending repetition rates above 600s/10 min. (better to drop or reduce text length), some IRDs could make timeout for caching these parts of EIT data.

Table 12.11.

EIT tables	Transport stream 1	Transport stream 2	Transport stream 3
Services inside TS	Service A, Service B, Service C	Service D, Service E, Service F	Service G, Service H,
EIT p/f actual,	EIT p/f for: Service A, Service B, Service C	EIT p/f for: Service D, Service E, Service F	EIT p/f for: Service G, Service H
EIT p/f other,	EIT p/f for: Service D, Service E, Service F, Service G, Service H,	EIT p/f for: Service A, Service B, Service C, Service G, Service H,	EIT p/f for: Service A, Service B, Service C, Service D, Service E, Service F
EIT sch actual	EIT sch for: Service A, Service B, Service C	EIT sch for: Service D, Service E, Service F	EIT sch for: Service G, Service H
EIT sch other	EIT sch for: Service D, Service E, Service F, Service G, Service H,	EIT sch for: Service A, Service B, Service C, Service G, Service H,	EIT sch for: Service A, Service B, Service C, Service D, Service E, Service F

Table 12.12.

IRDs has limited amount of RAM memory that can be used for processing and store EIT data. The transmitted EIT data can in some cases consume quite much of the available memory for EIT/EPG data in the IRD. Network/operator should be aware that a huge amount of EIT data could lead to e.g., IRD prioritises and skips part of the data EIT and that the presented EPG in not “complete”.

**EIT p/f (present/following):** It is mandatory to transmit EIT p/f actual (Table\_id 0x4E) and other (Table\_id 0x4F) sections for all services signalled as visible in the NorDig Logical Channel descriptor on the actual transport stream (visible\_service\_flag set to “1”).

**EIT sch (schedule):** Schedule program guide information may for example be distributed within broadcast as part of the DVB EIT stream or as application data (e.g. HbbTV broadband distributed) depending on network’s IRD support, broadcasters etc. Here, only the broadcasted alternative with EIT schedule is described, see more at section 12.4.7 below. NorDig (and DVB) has not defined any (lossless) compression of EIT data for the transmission nor requiring NorDig IRD to support de-compression of compressed EIT data (however DVB has described some basic parts for compression of tables), this means that all EIT data playout needs to be a raw uncompressed playout.

**Informative:** Unless the Network/Operator has specified other, NorDig IRDs support EIT present/following (p/f) and EIT schedule (sch) for both actual and other tables (1) up to at least 8 days of schedules.

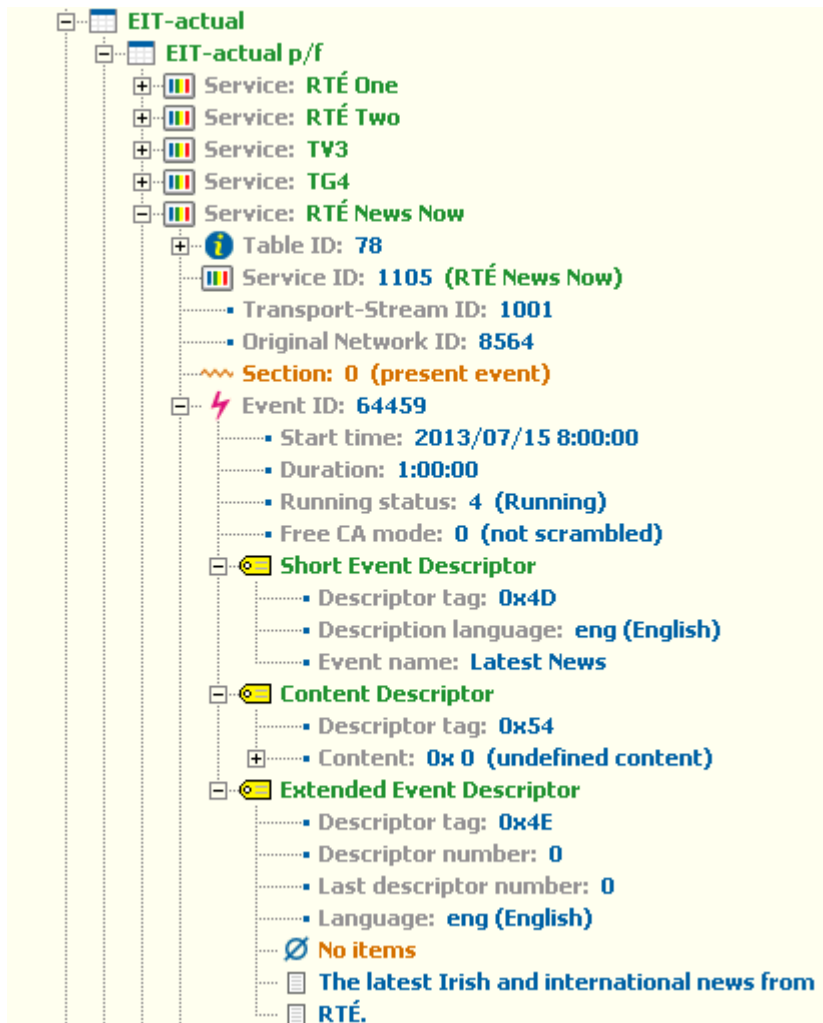

Figure 12.3: Typical (Event Information Table) EIT - actual p/f structure.

### 12.4.2 The Event Information Table Descriptors

Event descriptors	EIT p/f	EIT sch
Short_event_descriptor	M	M (1)
Extended_event_descriptor	M	M (1)
Component_descriptor	M	O
Content_descriptor	M	M (1)
Parental_rating_descriptor	M	M (1)
CA_identifier_descriptor (optional)	O	O
Content_identifier_descriptor	M (2)	M (2)

Table 12.13: EIT descriptors

Note 1: EIT schedule is recommended (optional) for NorDig IRDs with LTE.

Note 2: NorDig PVR only.

**Additional information about descriptors not explicitly described in the NorDig Unified IRD specification** (these NorDig Rules of Operation follows the NorDig Unified IRD specification basic chapter layout and to avoid changing layout here following descriptors are listed below without giving each descriptor its own subsection).

<i>short_event_descriptor:</i>	A <i>short_event_descriptor</i> (0x4D) shall contain the programme title and possibly a short (less than 256 characters) text information about the event.
<i>extended_event_descriptor:</i>	An <i>extended_event_descriptor</i> (0x4E) shall contain extended text information about the event and acts as a supplement to/or instead of the <i>short_event_descriptor</i> which would then only contain the programme title.
<i>content_descriptor:</i>	A <i>content_descriptor</i> (0x54) classifies the event according to certain content classes (genre) as specified by DVB SI specification EN 300 468 6.2.9. Support for <i>content_nibble_level_1</i> is mandatory, level 2 is optional.
<i>parental_rating_descriptor:</i>	A <i>parental_rating_descriptor</i> (0x55) provides the recommended age rating and identifies the country of the originating broadcaster, as specified by DVB SI specification EN 300 468 6.2.28. In addition for presenting this information in the EPG, the NorDig IRDs uses this descriptor also for parental blocking.
<i>Content_identifier_descriptor:</i>	A <i>content_identifier_descriptor</i> (0x76) is transmitted to associate a CRID to a event and is placed in the event loop of the EIT.

The below extract is a typical example of XML employed to generate EIT data, the section in bold pertains to the event detailed in Figure 12.4.

```

</event>
<event end_time="20130715 08:00:00" event_id="62265" event_seq="A62265" start_time="20130715
06:00:00" title="">
<description extended_synopsis="Cathal MacCoille, Rachael English and Gavin Jennings with news,
business news, sports news, travel and a review of the morning's papers." language="eng"
short_synopsis="" title="Morning Ireland"/>
<content_nibble1="0" nibble2="0"/>
</event>

<event end_time="20130715 09:00:00" event_id="64459" event_seq="A64459"
start_time="20130715 08:00:00" title="">

```

```

<description extended_synopsis="The latest Irish and international news from RTÅ%œ."
language="eng" short_synopsis="" title="Latest News"/>
<content nibble1="0" nibble2="0"/>
</event>
<event end_time="20130715 10:00:00" event_id="64460" event_seq="A64460" start_time="20130715
09:00:00" title="">
<description extended_synopsis="The latest Irish and international news from RTÅ%œ." language="eng"
short_synopsis="" title="Latest News"/>
<content nibble1="0" nibble2="0"/>
</event>

```

Figure 12.4: Extract from XML used to generate EIT.

#### 12.4.3 CA Identifier Descriptor

In most cases, transmitting this optional CA identifier data in the EIT is in very little use for the viewers, especially for the EIT schedule (often better to signalise this in SDT). Depending on what the Operator/Broadcaster wishes to present to the viewer, it may have some value for services toggling between being scrambled and being unscrambled over its broadcast hours. For such a case it could be enough to only include this descriptor in the EIT for time periods/events for one of the two scrambling status of the service (if the Network wishes to save EIT data amount).

#### 12.4.4 Content Descriptor

A *content\_descriptor* (0x54) classifies the event according to certain content classes (genre) as specified by DVB SI specification EN 300 468 [13],6.2.9. Support for *content\_nibble\_level\_1* is mandatory, level 2 is optional.

#### 12.4.5 Content Identifier Descriptor (NorDig PVR only)

A *content\_identifier\_descriptor* (0x76) is transmitted to associate a CRID to a event and is placed in the event loop of the EIT.

Networks that with the EIT data target to support PVRs and IRDs that can make a triggered recording (based upon TV Anytime CRIDs) should include Content Identifier Descriptor for all scheduled days in the EIT schedule (i.e. not just for EIT p/f and first day).

For more information, see NorDig Unified IRD specification.

#### 12.4.6 CRID encoding and reuse (NorDig PVR only)

See NorDig Unified IRD specification.

#### 12.4.7 Event Information Table Schedule

**EIT sch (schedule)** provides schedule information for a longer time period into the EPG, e.g. 7-days.

**Reduction of text length:** If bandwidth is limited and repetition rates becomes too long, an alternative could be to reduce the text description/length and component descriptions when the events will be present further in the future. E.g. present day could have long description for the events while day 7 events description could be reduced to shorter text description of each events (compared to present day and EIT p/f) and minimum/(no) of component descriptions.

**EIT sch broadcast alternatives:** EIT schedule (transmitted within the broadcasted signal) may use two main methods, method 1: broadcast EIT sch in all MPEG transport streams (including ‘*cross distribution*’) or method 2: broadcast EIT sch only in one of the network’s transport streams (‘*barker channel*’). (For the ‘*barker channel*’ EIT sch alternative refers to that EIT p/f is sent in all transport



streams but the EIT sch data is sent only on one of the transport streams). It is not certain that all legacy NorDig IRDs supports EIT sch with *'barker channel'*, unless the Platform/Operator has clearly required this for the Network.

**EIT sch using a *'cross distributed'*** (method 1): *cross distributed* refers to that all EIT streams in all transport streams of the network are complete with EIT data for all services in the network (both actual and other transport streams). The IRDs can cache EIT data of the network in the background independently of which service in the network it is presently decoding. If possible, it is recommended to use method 1 (EIT sch on all transport streams) before method 2 (*'barker channel'*).

**EIT sch using a *'barker channel'*** (method 2): All transport streams in the network should contain a link to the EIT schedule information, implemented by a *linkage\_descriptor* in the NIT. Linkage\_type 0x04 is used for the EIT schedule information. The parameter "service\_id" in the *linkage\_descriptor* is not applicable when linkage\_type 0x04 is used, i.e. set service\_id to 0x0.

The disadvantage with *'barker channel'* EIT schedule alternative is that basic (single tuner) IRDs can not keep decoding selected service and display it in the background when opening and displaying the EPG (unless the viewer is watching a service that happens to be on the same transport stream as the *'barker channel'* EIT sch stream) and that (single tuner) IRDs has difficult in caching EIT schedule and updating EPG in the background. (IRDs with two or more tuners (e.g. PVR) could potentially avoid these issues for *'barker channel'* EIT sch).

*The 'barker channel' EIT schedule was more common in early DVB Network, when EIT playout system cycles EIT with fixed repetition rates (instead of varying repetition rates into a fixed bitrate for the EIT) and in Networks with huge amount services. Very early legacy IRDs did not all support EIT sch (only supported EIT p/f and then in some Networks used an API application for the schedule data).*

## 12.4.8 Component Descriptor

### 12.4.8.1 General

A *component\_descriptor* (0x50) identifies all the components associated with the service for the running event, this can indicate whether a current or future event has additional components which may be of interest to the viewer, such as subtitles or audio description.

The *component\_descriptor* provides additional technical information of the program event (e.g. this program event has multichannel audio, this event has Hard of Hearing subtitling etc). The IRD typically uses the information inside the *component\_descriptor* together with other event information (event name, event description, schedule time etc) when presenting for example EPG or info banner for the viewer (i.e. not used for the actual part of the decoding process of the selected service). As a guideline it could be to include component information that is of special interest among viewers and information that differ from the regular broadcast for this service or other services inside the network (e.g. a service that regularly broadcast stereo audio, but sometimes has multichannel, it could be of interest to at least include component information for the few events that has real multichannel audio). Other information which are more static and common for the service or all services inside the network, these could be excluded in order to save data and bandwidth for the EIT (like a service that is always broadcasted in 16:9 video or always carries an EBU Teletext service, these component information values could be omitted).

### 12.4.8.2 Audio specific signalling in the Event Information Table

The type and the editorial characteristics of audio component should be signalled by dedicated *component\_types* in the *component\_descriptor*.

The presence of the *component\_descriptor* in the EIT is optional and up to the broadcaster/operator.

The following table provides an overview on the available *component\_types* used to characterize related audio components:

Audio codec	configuration	stream_content	stream_content_ext	component_type
MPEG-1 Layer 2 audio	Mono	0x2	n/a 0xF	0x01
	stereo			0x03
	receiver-mix audio description			0x47
	broadcast-mix audio description			0x48
(E-)AC-3		0x4	n/a 0xF	See below
MPEG-4 AAC / HE AAC (1)	Mono	0x6	n/a 0xF	0x01
	Stereo			0x03
	Multichannel			0x05
	receiver-mix audio description			0x47
	broadcast-mix audio description			0x48
AC-4		0x9	0x1	0x0E
NGA preselections		0xB	0xE	See below
Note 1: Applicable for MPEG-4 audio streams that conform to the AAC Profile (often referred to as AAC low complexity) and the High Efficiency AAC Profile; not applicable for streams that conform to the High Efficiency AAC v2 Profile.				

Table 12.14: Audio specific component\_type value assignment.

#### component\_type for (E-)AC-3 audio modes

For the usage with audio coding modes supported in the scope of the NorDig specification, the component\_type assignments can be simplified as follows:

component_type bits		
b <sub>7</sub> (MSB)	b <sub>6</sub> to b <sub>3</sub>	b <sub>2</sub> to b <sub>0</sub>
<b>E-AC-3 flag:</b>	<b>Service type:</b>	<b>Channel Mode:</b>
0: stream is AC-3 1: stream is E-AC-3	1000: Normal audio 1010: broadcast-mixed AD 0010: receiver-mixed AD (supplementary stream)	000: Mono 010: Stereo 100: Multichannel (5.1)

Table 12.15.

For example, a normal audio, multichannel 5.1 stream encoded in E-AC-3 uses a component\_type of 11000100 = 0xC4. A supplementary audio stream carrying the receiver-mix audio description component uses a component\_type of 10010000 = 0x90.

For all other assignments see the DVB SI specification in ETSI EN 300 468 [13].

#### component\_type for NGA Preselections

For NGA, one instance of a component\_descriptor should signal the used codec; in particular for AC-4 audio, this descriptor signals stream\_content set to 0x9, stream\_content\_ext 0x1 and component\_type set to 0x0E.

In addition, another instance of the component\_descriptor can be put into the corresponding descriptor loop for each NGA preselection available for the whole service. In this case, with stream content set to 0xB, stream\_content\_ext set to 0xE and component type set according to the following table:

component_type bits		Description
b <sub>7</sub> (MSB)		Reserved zero for future use
b <sub>6</sub>		content is pre-rendered for consumption with headphones
b <sub>5</sub>		content enables interactivity
b <sub>4</sub>		content enables dialogue enhancement
b <sub>3</sub>		content contains spoken subtitles
b <sub>2</sub>		content contains audio description
<b>b<sub>1</sub></b>	<b>b<sub>0</sub></b>	Preferred reproduction channel layout:
0	0	no preference
0	1	stereo
1	0	two-dimensional
1	1	three-dimensional

Table 12.16: Next-generation audio component\_type value assignment.

## 12.5 Time and Date Table and Time Offset Table

### 12.5.1 Time Date Table (TDT)

TDT is mandatory in each transport stream in the network, Table\_id 0x70 and is used by the IRDs to load and update its real-time clock and time/date (calendar). The time accuracy shall be within  $\pm 2$  seconds from UTC.

Each section of the TDT **shall** be transmitted every 10000 ms.

### 12.5.2 Time Offset Table (TOT)

TOT is mandatory in each transport stream in the network, Table\_id 0x73 and is used by the IRD to determine current local time offset from UTC and when next change in local time offset occurs (due to daylight saving time changes). IRDs typically use next time offset value when presenting the EPG that overlap the change in local time offset but relies upon the current local time offset to set the time that is presented to the viewer. (As by year 2021, some European countries has decided or may decide to stop changing yearly local time due to daylight saving time in the future).

The time accuracy shall be within  $\pm 2$  seconds from UTC. Each section of the TOT shall be transmitted every 10000 ms. The TOT shall be advanced or retarded to signal daylight savings time commencement or end.

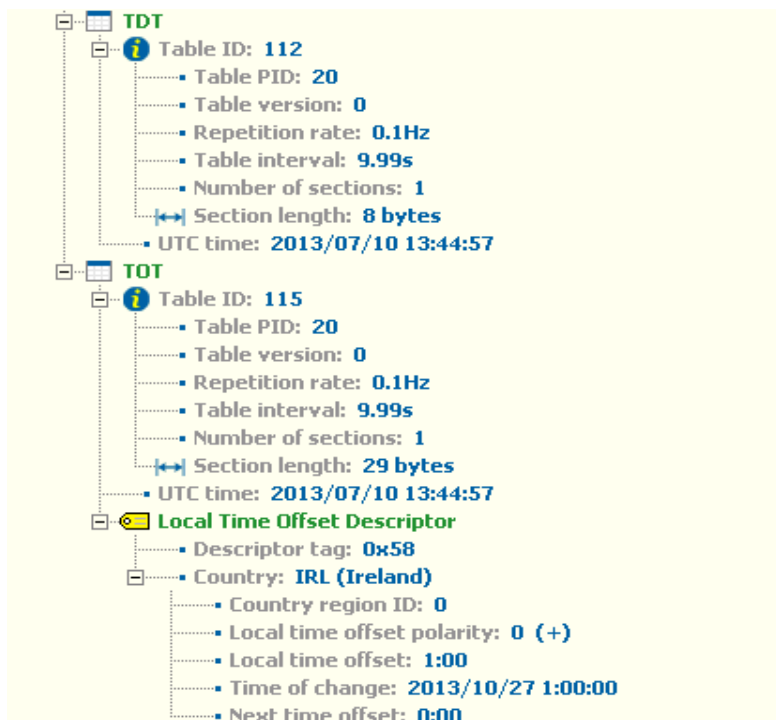

Figure 12.5: Typical TDT TOT table structure.

### 12.5.3 Time Offset Table Descriptor

Time Offset Table
local_time_offset_descriptor

Table 12.17: TOT descriptors.

local\_time\_offset\_descriptor: The local\_time\_offset\_descriptor (0x58) shall be transmitted and will operate within the range UTC +1 or UTC +2 dependent on the time of year.

Currently the following country\_codes are defined in this descriptor for the NorDig region:

DEN, FIN, ICE, IRL,NOR, SWE

The parameter "country\_region\_id" is set to zero for all these countries. (Country region id is used for countries with multiple time zones).

If and/or when countries stop changing for daylight saving time, the next\_time\_offset value should be set to the same value as local\_time\_offset. The time\_of\_change value may be the last date changing or set to long time in the future.

### 12.6 Conditional Access and Program Map Tables

**PAT:** The Program Association Table (PAT) is mandatory and shall always be transmitted on PID 0x0000. The PAT lists the packet identifier (PID) for all programmes available in the transport stream (PMT); the PAT also provides the location of the Network Information Table (NIT). The PAT shall be transmitted at least every 500ms (typically around every 100ms, it will affect zapping time).

**CAT:** The Conditional Access Table (CAT) shall be transmitted whenever at least one service component in the transport stream is encrypted. The CAT shall be transmitted on PID 0x0001. (CAT repetition rate does not affect zapping time).

**PMT:** For each service within a transport stream there shall be a corresponding Program Map Table (PMT). The PMT shall be encoded according to ISO/IEC 13818-1 [50] and there shall be separate program\_map\_PIDs for each service. The PMT also indicates the programme clock reference (PCR) for the service. The PMT may be transmitted on PID 0x20 to 0x1FFD (decimal 32 to 8189).

The PMT shall be transmitted at least every 500 ms (typically around every 100ms, it will affect zapping time).

Note: The NorDig IRD is required to continually monitor the PMT for changes (see NorDig Unified 3.1.1 **Error! Reference source not found.**, sections 12.1 and 6.9). They are mandated to support the descriptors within the CAT and the PMT as listed in the following sections.

### 12.6.1 Conditional Access Table Descriptors

Conditional Access Table
CA_descriptor

Table 12.18: CAT descriptors.

CA descriptor:

The *CA\_descriptor* identifies the CA\_System\_Id of the operator as well as the pointer to EMM packet identifier (PID), it may also support the insertion of private data.

### 12.6.2 Program Map Table Descriptors

Program map Table
metadata_descriptor (3)
teletext_descriptor
Subtitling_descriptor
stream_identifier_descriptor
video_stream_descriptor
audio_stream_descriptor
CA_descriptor
ISO_639_language_descriptor
MPEG-4_video_descriptor
AC-3_descriptor
Enhanced_AC-3_descriptor
AC-4_descriptor (4)
AAC_descriptor
Supplementary_audio_descriptor
audio_preselection_descriptor (5)
Private_data_specifier_descriptor
data_broadcast_id_descriptor (1)
application_signalling_descriptor (2)
carousel_id_descriptor (1)
related_content_descriptor (3)
TTML_subtitling_descriptor (4)

Table 12.19: PMT descriptors.

Note 1: Use of the `data_broadcast_id_descriptor` and the `carousel_identifier_descriptor` for signalling relevant for the SSU is specified in ref ETSI TS 102 006 [28], see also section 12.7.

Note 2: Only mandatory for the NorDig HbbTV IRDs

Note 3: Only mandatory for NorDig PVR IRDs.

Note 4: Only mandatory for NorDig HEVC IRDs.

Note 5: The processing of `audio_preselection_descriptor` is highly recommended in the NGA capable Nordig HEVC IRD and should be supported in new IRDs. It is expected that `audio_preselection_descriptor` processing, especially languages, will become mandatory in future versions of this specification.

**Additional information about descriptors not explicitly described in the NorDig Unified IRD specification** (this NorDig Rules of Operation follows the NorDig Unified IRD specification basic chapter layout and to avoid changing this chapter layout following descriptors are listed here below without giving each descriptor its own subsection).

- Video descriptor: Optional to use for normal MPEG-2 Video, mainly used for MPEG-2 still picture mode video. (For normal MPEG-2 Video it is minimum to signal via `stream_type` in PMT). MPEG 2 Video is signalled by the `video_stream_descriptor` as per ISO 13818-1 **Error! Reference source not found..** The descriptor shall be placed in the descriptor loop for the video element of the PMT with a tag value of 0x02.
- MPEG-4 Video descriptor: Optional to use for normal MPEG-4/AVC/H.264 Video, mainly used for AVC/H.264 still picture mode video. (For normal AVC/H.264 Video it is minimum to signal via `stream_type` in PMT). MPEG 4 Video is signalled by the `AVC_video_descriptor` as per ISO 13818-1 **Error! Reference source not found..** The descriptor shall be placed in the descriptor loop for the video element of the PMT with a tag value of 0x28
- Audio stream descriptor: Optional to use (it is minimum to signal via `stream_type` in PMT). MPEG-1 L II Audio is signalled by the `audio_stream_descriptor` as per ISO 13818-1 [50].The descriptor shall be placed in the descriptor loop for the audio element of the PMT with a tag value of 0x03.
- Extension descriptor: The extension descriptor is used to extend the 8-bit namespace of the `descriptor_tag` field as per ETSI EN 300 468 [13], section 6.2.16. Descriptors carried in the extension descriptor are identified through the `extension_tag` value.
- Teletext descriptor: Mandatory whenever a teletext component is defined and shall be inserted in the descriptor loop for the teletext element of the PMT with tag value 0x56.

The syntax shall be according to ETSI EN 300 468 [13] teletext\_type 0x01 initial teletext page, teletext\_type 0x02 teletext subtitle page.

- Subtitling descriptor: Mandatory whenever DVB bitmap subtitles are transmitted and shall be inserted in the descriptor loop for the subtitling element of the PMT with tag value 0x59.
- Stream identifier descriptor: Mandatory whenever the service contains more than one stream of the same type and there are component descriptors for that type of stream within the EIT, it shall be inserted in the descriptor loop of the PMT with tag value 0x52.
- Service move descriptor: Mandatory whenever a service is moved from one transport stream to another. The syntax shall be according to ETSI EN 300 468 [13]. As soon as the service is available in the new transport stream, a service\_move\_descriptor shall be inserted in the PMT in the original transport stream with tag value 0x60.
- Data broadcast descriptor: Mandatory whenever MHEG-5 or HbbTV applications are transmitted or when System Software Update (SSU) is transmitted. The syntax shall be according to ETSI EN 300 468 [13] a data\_broadcast\_id\_descriptor shall be inserted in the PMT in the original transport stream with tag value 0x66 and a data\_broadcast\_id 0xA “system software update”.

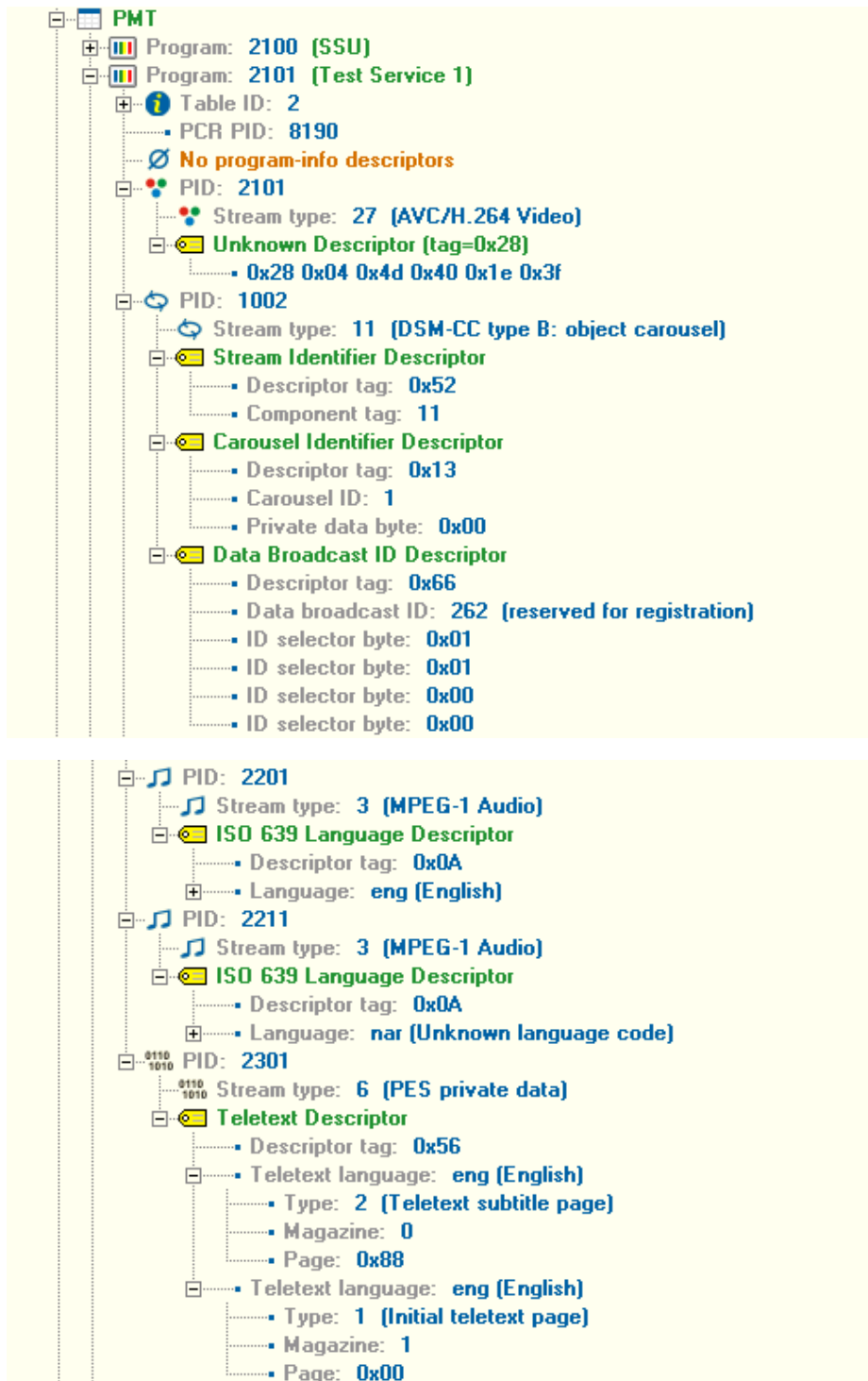

Figure 12.6: Typical PMT tree with descriptors.

### 12.6.3 Component priority multiple video or audio streams

NorDig has defined priority order inside a service that includes multiple video or multiple audio streams/PIDs, see NorDig IRD spec (e.g. a service could contain one MPEG-4/AVC/H.264 video stream plus one MPEG-H/HEVC/H.265 video stream).

As a guideline for the transmission could be to first list components/PIDs in the PMT of the ones using older generation technology and/or the ones targeting the biggest population viewers (typically viewers



with “normal” user preference settings i.e. no supplementary audio/subtitling...). For example, MPEG4/AVC video PID before HEVC video PID and “normal” audio before Audio Description audio etc). This could be helpful to reduce that some older legacy IRDs to not select “wrong” PID.

#### 12.6.4 ISO 639 language descriptor

The ISO\_639\_language\_descriptor as per ISO 13818-1 [50] (section 2.6.18), is mainly used for audio streams but may also be used for other stream types (1). When used it shall be placed in the descriptor loop for the element stream/PID of the PMT with a tag value of 0x0A.

Note 1: For EBU Teletext, DVB Subtitling and TTML Subtitling streams use their own descriptors which include language information. The ISO\_639\_language\_descriptor is not required for these types of subtitling streams.

##### 12.6.4.1 ISO 639 language descriptor used for Audio streams

This descriptor shall be used for all audio streams/PIDs coded in either the MPEG-1 Layer II, AC-3, E-AC-3 or HE-AAC format defined in the PMT (both ‘normal’ and supplementary audio) see also 6.4.3 in Audio section (an exception could be for some cases with only a single audio stream for a service, but then the IRD will not be able to present audio language information about the service). For NGA/AC-4 streams, the presence of an ISO\_639\_language\_descriptor is recommended (only being necessary in order to serve HEVC IRDs not understanding the APD (audio\_presentaion\_descriptor)).

In general, the following advices should be considered for best user experiences on legacy IRDs:

**Language code:** To avoid issues in legacy IRDs, it is recommended to set the ISO\_639\_language\_code to ‘nar’ (“narrative”) in the ISO\_639\_language\_descriptor for supplementary audio streams (audio description, spoken subtitling etc) and then in supplementary\_audio\_descriptor use “correct” language for the supplementary audio stream. See more about usage and recommendations of language codes in section 12.1.8 Country and Language Codes within PSI/SI and in section 6.4.3 Audio related signalling considerations above.

**Audio type:** For “Normal audio”, the audio\_type field shall be set to 0x00 ‘undefined’ audio. Due to legacy IRDs, it is recommended to use audio type 0x00 ‘undefined’ in the ISO\_639\_language\_descriptor for Supplementary Audio streams (audio description, spoken subtitling etc) and then in supplementary\_audio\_descriptor use “correct” audio type for the supplementary audio stream. See more in NorDig Unified IRD specification section 12.6.8 for further information about Supplementary Audio.

**Broadcast mix supplementary audio:** Some legacy IRDs has been reported to get triggered to do receiver mixing when it detects two audio PIDs with same language (e.g. Swedish) and when one has audio type 0x00 ‘undefined’ and one has audio type 0x03 ‘Visual impaired commentary’/audio description in the ISO\_639\_language\_descriptor (this when language matching IRDs user preference settings and IRD has AD on).

For all audio streams carrying supplementary audio (audio description, spoken subtitling etc) **shall** also use a supplementary\_audio\_descriptor.

Language (in English)	ISO 639-2	Translation	NorDig IRD support and comments
	Code	To native	
Danish	dan	Dansk	mandatory
English	eng	English	mandatory
Finnish	fin	Suomi	mandatory
Irish / Gaelic	iri	Gaeilge	Mandatory, ISO 639-2 Bibliographic
Irish / Gaelic	gle	Gaeilge	Mandatory, ISO 639-2 Terminological
Norwegian	nor	Norsk	mandatory
Narrative	nar		recommended (optional), may be used for supplementary audio streams/audio description
Original language	qaa	Original (dan) Original (eng) Alkuperäinen (fin) Bunaidh (gle) Original (nor) Original (swe)	recommended (optional)
Sami	smi	Sámegiella	mandatory
Swedish	swe	Svenska	mandatory
Undefined	und	Udefinert (dan) Undefined (eng) Määrittelemätön (fin) Neamhshainithe (gle) Udefinert (nor) Odefinierat (swe)	Optional, treated same as original language (qaa)

Table 12.20: Language descriptors.

‘nar’ is a non-allocated code in ISO 639 Part 2, intended here to represent “narrative”. Some networks may even use European language that is not used in that country, e.g., in Finland the language Dutch may be used for the supplementary audio streams in some networks.

#### 12.6.5 AC-3 descriptor

AC-3 Audio shall be signalled by the AC-3\_descriptor as per ETSI EN 300 468 [13] section D.3. The descriptor shall be placed in the descriptor loop for the audio element of the PMT with a tag value of 0x6A. For all audio streams carrying supplementary audio (audio description, spoken subtitling etc) should also use a supplementary\_audio\_descriptor.

For AC-3 audio streams carrying broadcast mixed Supplementary Audio, the ‘service type flags’ should be set to Visually Impaired (VI) in the AC-3 descriptor.

Note: AC-3 is not suitable for receiver mixed Supplementary Audio and NorDig IRDs are not required to support this.

#### 12.6.6 Enhanced AC-3 descriptor

Enhanced AC-3 Audio shall be signalled by the enhanced\_AC-3\_descriptor as per ETSI EN 300 468 [13], section D.5. The descriptor shall be placed in the descriptor loop for the audio element of the PMT with a tag value of 0x7A. For all audio streams carrying supplementary audio (audio description, spoken subtitling etc) should also use a supplementary\_audio\_descriptor.

For E-AC-3 audio streams carrying broadcast mixed Supplementary Audio (separate PID), the ‘service type flags’ should be set to Visually Impaired (VI) and the full service flag set to broadcast mixed audio (value ‘1’) in the enhanced\_AC-3\_descriptor.

For E-AC-3 audio streams carrying receiver mixed Supplementary Audio, the ‘service type flags’ should be set to Visually Impaired (VI) and the full service flag’ set to receiver mixed audio (value ‘0’) in the enhanced\_AC-3\_descriptor. (However not all legacy NorDig IRDs might support receiver mixing).

### 12.6.7 AAC descriptor

MPEG-4 HE-AAC Audio shall be signalled by the AAC\_descriptor as per ETSI EN 300 468 [13], section H.2. The descriptor shall be placed in the descriptor loop for the audio element of the PMT with a tag value of 0x7C.

To avoid inconsistency, it is recommended to not transmit the MPEG-4\_audio\_descriptor when transmitting the AAC\_descriptor.

All audio streams carrying supplementary audio (audio description, spoken subtitling etc) shall also use a supplementary\_audio\_descriptor, see 6.4.3 and 12.6.8.

When broadcasting more than one audio stream within same service (e.g., one stereo and one dynamically changing multichannel audio PID) it is recommended to keep the signalling of the ‘profile and level’ and ‘AAC type’ static inside the AAC\_descriptor and typically signal the maximum ‘profile and level’ and ‘AAC type’ that the audio stream may have in transmission (instead of that descriptor signalling follows the actual encoding). This aims to avoid that IRDs is selecting “wrong” audio PID compared to user preference settings (viewers may for example zap to the service a couple of minutes before a specific program event start (e.g. movie) which changes dynamic multichannel audio to stereo audio mode.

Tables below shows values for ‘profile and level’ and ‘AAC type’ that should be used in the AAC\_descriptor.

profile and level value	Description	NorDig comment
0x51	LC-AAC Level 2	no SBR used, up to stereo (mono or stereo)
0x52	LC-AAC Level 4	no SBR used, up to 5.1 (e.g. mono, stereo, 5.1)
0x58	HE-AAC Level 2	SBR may be used, up to stereo
0x5A	HE-AAC Level 4	SBR may be used, up to 5.1(e.g. mono, stereo, 5.1)

Table 12.21: AAC descriptor’s Profile and level values for NorDig IRDs.

AAC type value	Description	NorDig comment
0x01	HE-AAC audio, single mono channel	trigger for normal (mono) audio
0x03	HE-AAC audio, stereo	trigger for normal (stereo) audio
0x05	HE-AAC audio, surround sound	trigger for normal (multichannel) audio
0x42	HE-AAC Receiver mixed Supplementary Audio as per annex E of TS 101 154	If no supplementary audio descriptor is included, then this trigger IRDs for receiver mixed Supplementary Audio and this audio stream may include any AD_descriptor in PES_private_data for pan and fade control.
0x47	HE-AAC receiver mix Audio Description for the visually impaired	If no supplementary audio descriptor is included, then this triggers IRDs for receiver mixed Supplementary Audio and this audio stream <u>not</u> include any AD_descriptor in PES_private_data.
0x48	HE-AAC broadcast mix Audio Description for the visually impaired	If no supplementary audio descriptor is included, then this descriptor triggers IRDs for broadcast pre-mixed Supplementary Audio

Table 12.22: AAC descriptor's AAC type values for NorDig IRDs.

Note: DVB defined descriptor AAC\_descriptor tag 0x7C replaces the MPEG defined descriptor MPEG4\_audio\_descriptor.

### 12.6.8 Supplementary\_audio\_descriptor

All Supplementary Audio streams/PIDs (both Broadcast mixed and Receiver mixed) coded in MPEG-1 Layer II, AC-3, E-AC-3 or HE-AAC format (2) shall be signalled by the broadcaster in the stream by means of the Supplementary Audio Descriptor. The supplementary audio descriptor may also be used for the “normal audio” streams, since the IRD has to parse the descriptor to determine the audio type.

The descriptor shall be placed in the descriptor loop for the audio element of the PMT using the DVB extension\_descriptor and an extension tag value of 0x06.

In the supplementary\_audio\_descriptor, **mix\_type** is typically set to ‘1’. This applies to stream carrying “Normal Audio”, but also to streams providing “broadcast-mixed” accessibility services.

Only secondary audio streams intended to be mixed with a normal audio stream shall signal **mix\_type** set to ‘0’ (“receiver mix”).

The **editorial\_classification** shall indicate the type of the audio stream. Streams carrying “Normal audio” indicate 0x00, while accessibility services audio stream signal 0x01 for Audio Description (AD) or 0x03 for Spoken Subtitles (SS) irrespectively of the mix\_type employed.

For the ISO\_639\_language\_code, the same rules as with the ISO\_639\_language\_descriptor should apply.

The table below shows how the values should be used in the Supplementary\_audio\_descriptor.

Audio type	Audio purpose	Mix type	editorial_classification
Normal	Main audio	1	0
SA broadcast mixed	Audio Description	1	1
SA receiver mixed	Audio Description	0	1
SA broadcast mixed	Spoken Subtitles	1	3
SA receiver mixed	Spoken Subtitles	0 (note 1)	3 (note 1)

*Table 12.23: Minimum number of combinations of the supplementary audio descriptor for the NorDig IRD. SA refers to Supplementary Audio.*

Note 1: Up to some version of the ETSI EN 300 468 (v1.13.1) it has been missed to include the important combination mix\_type '0' with editorial classification '3' (referring to receiver mixed Spoken Subtitles) and mentions that this is invalid and may not be used. However, NorDig overwrites this and make this combination valid and NorDig IRDs are required to support this.

Note 2: With NGA, accessibility services are an integral part of the NGA audio stream and therefore no supplementary audio streams will be used. Even if NGA receivers not understanding the APD (audio\_preselection\_descriptor) are targeted, accessibility services do not need to be signalled by legacy descriptors; those IRDs are still able to select an appropriate preselection from the NGA stream.

#### 12.6.9 Metadata descriptor NorDig PVR only, Broadcast Record Lists

See NorDig Unified IRD specification.

#### 12.6.10 Related Content Descriptor NorDig PVR only

See NorDig Unified IRD specification.

#### 12.6.11 Audio Preselection Descriptor (NGA services only)

Audio preselections in NGA / AC-4 audio streams shall be signalled by the audio\_preselection\_descriptor as per ETSI EN 300 468, section 6.4.1. [13]. The descriptor shall be placed in the descriptor loop for the audio element of the PMT using the DVB extension\_descriptor and an extension tag value of 0x19.

For each preselection, the audio\_preselection\_descriptor (APD) provides a language tag, some flags indicating the availability of accessibility features and an indication on the preferred reproduction layout in addition to an identifier for selection purposes towards the audio decoder. Optionally, preselections should be further differentiated by text labels carried in the message\_descriptor (extension tag 0x08), if the beforementioned parameter does not provide a comprehensive differentiation.

Not all presentations in the AC-4 elementary stream need to be reflected as preselections in an APD (audio\_preselection\_descriptor), but only those which are intended to be presented to and selectable by the user. On the other hand, the audio\_preselection\_descriptor may remain unchanged even if certain or all preselections are temporarily not available e.g. during commercial breaks and other interstitials. By this, the number of transitions in SI signalling is reduced compared to signalling within the NGA elementary stream where changes theoretically might occur every audio frame.

Note: If a selected preselection disappears, the AC-4 decoder will select an appropriate AC-4 presentation based on the user's preferences until the selected preselection is available again.

For AC-4 audio, Table 12.24 provides a mapping from elements of the APD (audio\_preselection\_descriptor) to corresponding elements in the AC-4 TOC.

APD Element	AC-4 TOC Element
Audio Preselection	ac4_presentation_v1_info()
preselection_id	presentation_id
audio_rendering_indication	Preferred reproduction layout (see below.)
audio_description	Accessibility Service: Audio Description Associated audio ac4_substream_group present with content_classifier of 010b (Associated service: visually impaired).
spoken_subtitles	Accessibility Service: Spoken Subtitles Associated audio ac4_substream_group present with content_classifier of 111b (Associated service: voice over).
dialogue_enhancement	(typically set to '1')
interactivity_enabled	(Reserved for future use.)
ISO_639_language_code	Primary language subtag of the language tag in the main audio or dialogue ac4_substream_group_info of the presentation, converted to ISO 639-2.
Text Label	Recommended but no expression in the elementary stream.

Table 12.24.

Note: The language tags in the AC-4 elementary stream strictly applies to BCP-47 while the language in the APD (audio\_preselection\_descriptor) is signalled using ISO 639-2 language tags. For example, the BCP-47 code of 'en-US' indicating "English as spoken in the United States" will read 'eng' in ISO 639-2.

The audio\_preselection\_descriptor should only signal "real" languages. Special language tags like "und", "mul", "mis", "qaa" or "nar" should be avoided. If audio streams targeting different languages are carried in multiple streams, then the audio\_preselection\_descriptor shall indicate all available languages in the NGA stream.

### Preferred reproduction channel layout

The audio\_rendering\_indication in the APD (audio\_preselection\_descriptor) should be set according to the pres\_ch\_mode and the b\_pre\_virtualized bit:

- If pres\_ch\_mode is 0 or 2, then audio\_rendering\_indication shall be set to 1.
- If pres\_ch\_mode is 1 and b\_pre\_virtualized is 0, then audio\_rendering\_indication shall be set to 1.
- If pres\_ch\_mode is 1 and b\_pre\_virtualized is 1, then audio\_rendering\_indication shall be set to 4.
- If pres\_ch\_mode is in the range from 3 to 8, then audio\_rendering\_indication shall be set to 2.
- If pres\_ch\_mode is 9 or higher, then audio\_rendering\_indication shall be set to 3.
- If pres\_ch\_mode is -1, then audio\_rendering\_indication shall be set to 3.

pres ch mode	b pre virtualized	audio rendering indication
0	any	1
1	0	1
1	1	4
2	any	1
3 – 8	any	2
9 – 15	any	3
-1	any	3

Table 12.25.

### Multiple Languages with multiple streams

If audio streams targeting different languages are carried in multiple streams, then the

audio\_preselection\_descriptor should indicate all available languages in the NGA stream unless all languages are available from this one and only NGA stream.

#### 12.6.12 AC-4 Descriptor

AC-4 audio is signalled by the ac-4\_descriptor as per ETSI EN 300 468 [13], section D.7, see also 6.4.4 in Audio section of this document. The descriptor shall be placed in the descriptor loop for the audio element of the PMT using the DVB extension\_descriptor and an extension tag value of 0x15.

**Informative:** The NGA capable Nordig HEVC IRD only uses the AC-4 descriptor to identify a PID/stream with stream\_type set to “private data” (0x06) to be an AC-4 stream. The NGA capable NorDig HEVC IRD ignores other information in the AC-4 descriptor (like audio format/channel mode and TOC) during the audio PID/Stream selection (see more in NorDig IRD specification 6.5.4 signalling to be used for audio property).

**Informative:** For NGA audio, it is assumed that for each language not more than one NGA stream is used for each language to address all audio types (Normal, Spoken Subtitles, etc.) and all the IRD’s output audio format modes (stereo, multichannel or immersive).

#### 12.7 **SSU UNT Descriptors**

See NorDig Unified IRD specification.

#### 12.8 **Related Content Table (NorDig PVR only)**

See NorDig Unified IRD specification.

#### 12.9 **NorDig Broadcast Record List syntax (NorDig PVR only)**

See NorDig Unified IRD specification.

## 13 Navigator

The Navigator is internal functions of the IRD. NorDig IRD Navigator refers to parts of the IRD that handles the menus and navigation that is used for the reception and presentation of digital-tv (an IRD, e.g., TV set, may also be used other non-digital-tv purposes, for example web browsing, streaming services etc).

Examples of the IRD navigator functions are handling of Service list, EPG/ESG, parental rating blocking, real-time clock, UI, Accessibility settings, etc. many of the Navigator functions uses incoming signalling described in section 12 above.

See chapter 3.1 Tuning and Navigation.



## 14 NorDig PVR

### 14.1 **General**

A NorDig PVR is a recordable IRD that fulfils all mandatory requirements specified in NorDig Unified IRD specification, chapter 14 (and relevant part in chapter 12 and 13), which among other things includes support for series recording, accurate recording, split recording etc. *(A NorDig IRD with some recording capability but which do not meet all mandatory NorDig PVR requirements is just a “NorDig IRD with recording capability”)*.

Programming a recording (or booking) in the PVR refers to the user action of making a booking to record a live event, series and/or other broadcast content, either to be scheduled in the future or for immediately recording.

The NorDig PVR specification is based solely upon broadcast signalling via DVB-SI, which is independent of Video and Audio formats of Application Interface (API), Conditional Access (CA) and Digital Rights Management (DRM) systems and is capable of operating in free-to-air and Pay TV modes.

The NorDig specifications are based on TV-Anytime standard signalling.

### 14.2 **Implementation overview**

#### 14.2.1 Broadcaster

The broadcaster is responsible for the description of the programme content via standardised DVB signalling and the distribution of that signalling transparently across their network to the PVR receiver.

Broadcaster schedule providers will generally generate and deliver content information via XML format. This XML schedule information is typically translated into DVB EIT (Event Information) tables prior to its inclusion within the transmitted DVB transport stream, the data typically comprises of EIT present/following (p/f) and EIT schedule, and other extended DVB SI signalling to support the PVR is also required.

It is a basic requirement that content providers (broadcast stations) ensure that their broadcast content (Video/Audio) run concurrent with the programme information supplied via EIT p/f and EIT schedule this is to avoid clipped recordings and poor PVR viewer / user experience.

#### 14.2.2 Signalling

The support of EIT p/f live updating is mandatory for the NorDig PVR.

The NorDig PVR specification is based on the TV Anytime standard for programme description and content, this specification employs the standard Content Reference Identifier (CRID) system for an advanced cross-platform handling of programme and content.

As mandatory, the broadcaster will support NorDig PVR signalling by employing a unique programme identifier for each programme event in order to distinguish individual programmes, identify a series of programmes or accommodate the split recording of programmes.

#### **There are 3 types of CRID supported in a NorDig network:**

A Programme CRID – to identify a specific piece of content (e.g. a programme)

A Series CRID – to group together an arbitrary selection of content (e.g. a series)

A Recommendation CRID – may point to a single event (in a programme or series)

**CRID types are to be used:**

0x01 Programme CRID

0x02 Series CRID

0x03 Recommendation CRID

**The NorDig PVR should ignore all other CRID types.**

For more information see **Appendix B** and “NorDig\_PVR\_metadata\_whitepaper\_ver\_1.0” at [www.nordig.org/specification](http://www.nordig.org/specification).

#### 14.2.3 Network operator

DVB signalling to support the NorDig PVR shall be implemented on all Multiplex’s within in the NorDig broadcast network as mandatory, this includes NIT, SDT, EIT p/f, EIT Schedule and extensions, this inclusion ensures that all broadcasters on the network who wish PVR functionality may support this by supplying the necessary data within their respective programme schedule(s).

Support of NorDig PVR signalling necessitates a slight increase in data payload and hence the bitrate required for transmission of EIT p/f, EIT schedule. Operators may choose to handle broadcaster and channel id CRID with abbreviations to save bandwidth capacity across the network.

In order to ensure that Live Programme Content updates are conveyed to the PVR via EIT p/f within 10 seconds of the live update occurring, it is strongly recommended to ensure that the data path from the content provider/ broadcaster to the PVR is as transparent as possible, it is necessary therefore that a direct data connection from Content Provider / Broadcaster scheduling system to the EIT generation system on the network head-end in order to accommodate this.

For more information about “last minute update” of EIT p/f see “NorDig TVA Guidelines Implementation package <b>Error! Reference source not found.</b>
--

#### 14.2.4 The Re-transmission of DTT to Cable or Satellite networks

For the support of NorDig PVR when employed on a cable or satellite network the broadcaster may choose to re-broadcast the DTT sourced transmission.

In such circumstances the broadcaster may choose to pass the complete PVR signalling requirement within EIT p/f and schedule along with programme content (Video, Audio, Teletext, Subtitling, Etc.), with the appropriate modifications to NIT (ONID, LCN), PMT, SDT etc.

Or otherwise, the broadcaster may choose to re-generate EIT p/f and EIT schedule from the original programme content provider XML for separate broadcast. This latter action may be necessary where certain programme rights issues are in place preventing the transmission of programme on the Cable or Satellite Network.

**See Appendix B, NorDig PVR for more information.**

## 15 IRD System Software and API

### 15.1 *NorDig Basic IRD*

No RoO specification.

### 15.2 *API – HbbTV*

#### 15.2.1 General

The NorDig Hybrid IRD will support all mandatory features as defined in the latest released version of the NorDig Unified Requirements. (available from [nordig.org](http://nordig.org)).

NorDig Broadcasters or Operators should liaise with manufacturers before launching new HbbTV applications or before publishing significant updates to existing HbbTV applications.

NorDig Broadcaster, Operators and application developers should be aware that the HbbTV test suite is not a substitute for testing real world scenarios and applications, nor does it offer a means to validate HbbTV applications not developed by HbbTV Association, as HbbTV expressly states:

“While the HbbTV test suite is designed to be as clear, complete and comprehensive as possible and constitutes a major goal of HbbTV, it is not possible to guarantee that the test suite has a complete coverage of the specification. The test suite alone does not provide a definitive measure of receiver compliance and makes no provision for testing application compliance.”

<https://www.hbbtv.org/overview/#hbbtv-overview>

NorDig Broadcaster, Operators and application developers should endeavour to perform extensive testing using representative TV platforms before launching their applications.

When necessary due to unresolved interoperability issues, the version signalled by the application and user agent can be used to control which TV platforms the application runs on.

NorDig Broadcasters or Operators are highly recommended to inform manufacturers when new or updated applications are intended to be launched, to allow manufacturers to support testing, in cooperation with NorDig Broadcasters or Operators, and to monitor any potential misbehaviour in the field and act quickly upon it. Launching applications early-to-mid week is encouraged, to ensure any issues can be addressed as quickly as possible in the following hours and days.

NorDig Broadcasters or Operators broadcasting HbbTV applications should provide manufacturers with contact information to enable manufacturers to report issues occurring in the field. Likewise, the Operator or Broadcaster responsible for the HbbTV application should liaise with affected manufacturers as soon as they become aware of issues. If the issues interfere with NorDig Hybrid IRD operation (e.g. crashes, freezes, service viewing disruption), the Operator or Broadcaster should immediately prevent the application from being run on the affected TV platforms (e.g. stop application broadcast or prevent the application from running on user agents of affected TV platforms).

Fast action support from the NorDig Broadcaster or Operator is paramount for reducing customer complaints and the burden on both manufacturers and the Broadcaster or Operator.

Note: A TV platform is a NorDig IRD unique design from a manufacturer that may be shared between different TV/STB models.

Usage of HbbTV may require the collection and handling of user private data, which may be subject to European privacy laws, such as GDPR, or legal frameworks with countries outside the European Community. NorDig Broadcasters or Operators are reminded that they have obligations under such laws and should take this into careful consideration when offering HbbTV applications.

### 15.2.2 HbbTV applications

Signalled applications **shall** be compliant with ETSI TS 102 796 v1.6.1 (“HbbTV v2.0.3”) [27] or with ETSI TS 102 796 v1.2.1 (“HbbTV1.5”).

Applications using DRM **shall** follow guidelines defined in ETSI TS 102 796 v1.6.1 [27] Annex D – DRM Integration, [see also 10.4 Communication between CAM and application].

### 15.2.3 Signalling of HbbTV application

The application signalling **shall** be fully compliant with ETSI TS 102 796 v1.6.1 [27].

- The AIT may signal additional versions of the application (e.g., one for HbbTV 1.5, one for HbbTV 1.0 and one for HbbTV 2.0.x).
- Application signalling descriptor shall be inserted into the relevant PMT loop together with HbbTV application type and AIT version number.
- A maximum of one PID shall carry AIT information in each service.
- HbbTV services without broadcast audio or video components will be signalled according to ETSI 102 796 [27], chapter 7.2.6.
- HbbTV services may be present on scrambled services and are expected to be received / detected by all receivers compliant with HbbTV, as defined in ETSI 102 796 [27], chapter 6.2.2.8.
- It is not expected that receivers will descramble AIT or DSM-CC carousels signalling and carrying applications. Scrambled Audio and Video components may be used to authenticate valid CA system entitlements, by using the onPlayStateChange status codes from AVObject class.
- DSM-CC stream events shall be used as defined in ETSI TS 102 796 [27].

When retransmitting broadcast signals between different networks (i.e. DVB-T to DVB-C), HbbTV signalling shall be considered as an essential part of the service and its signalling including the AIT and DSM-CC carousels (including stream event carousels) must be retained as-is. (PID re-mapping is permitted). Special care must be observed when re-creating PMTs in order to maintain correct component tags for carousels.

If the operator is signalling its own HbbTV applications, the original applications from the broadcaster shall be included in the transmission as well.

### 15.2.4 HbbTV and EBU Teletext

An operator may transmit an application in the AIT with the usage type in the application\_usage\_descriptor set to 0x1 together with EBU Teletext magazine.

### 15.2.5 Simultaneous EBU Teletext and HbbTV Digital Teletext

Services may have both an EBU Teletext service and an HbbTV Digital Teletext application signalled and available.

### 15.2.6 Detecting capabilities

No application **shall** start a video object without prior checking the capabilities of the IRD (e.g., if the IRD supports MPEG DASH) to avoid conflict and ensuing errors.

For this purpose, the signalled application **shall** make use of xmlCapabilities as defined in in ETSI TS 102 796 [27], chapter 10.2.4, to detect the capabilities of the IRD for media delivery and decryption (e.g., MPEG DASH and DRM Object support).

### 15.2.7 Communication between CAM and application

The communication between the CI+ CAM and the application may be used.

Possible non exhaustive list of use cases may be:

- Identification of the user via the smart card (if present)
- Communication from the CAM module for any specific information. This may be retrieving any information over LSC or information generated in the CAM.

For this purpose, the DRM Agent API as defined in ETSI TS 102 796 [27], Annex F, chapter F.3 are used.

#### 15.2.8 Content via the CEA-2014 A/V Object

If DRM is used to protect content presented via the CEA-2014 A/V object then it has to be signalled as defined in ETSI TS 102 796 V1.6.1 [27], Annex F, chapter F.4.

A DRM System ID for the DRM system needs to be registered as described in OIPF DAE specification [6], clause 9.3.10. Refer to ETSI TS 102 796 [27], Annex F, chapter F.2.

#### 15.2.9 MPEG DASH

If a broadcaster is using DASH in their services, the DASH streams **shall** be validated with the DASH-IF Conformance Tool located at <https://conformance.dashif.org/>.

ETSI TS 102 796 v1.6.1 (“HbbTV 2.0.3”) [27] requires support for framerate transitions as defined in ETSI TS 103 285 v1.2.1.

Transition between framerates may be used, although HbbTV Specification 1.5 does not mandate support for it (ETSI TS 102 796 v1.2.1, chapter E.4.2.1), and legacy NorDig Hybrid IRDs may not support it.

## **16 User Preferences**

No RoO specification.

## Annex A: NorDig Members and Partners

The NorDig group represents per January 2018 the following broadcasters, operators and other companies in the Nordic countries and Eire:

### 1 NorDig Full Members

#### Denmark

---

Danmarks Radio (DR)  
Stofa  
TV2 Danmark A/S  
TDC A/S (former YouSee)

#### Eire

---

2RN (RTÉ Transmission Network Ltd.)

#### Finland

---

Digita OY  
Labwise Ltd.  
Yleisradio (YLE)

#### Norway

---

Canal Digital  
Norges Televisjon AS (NTV)  
Norsk Rikskringkasting AS (NRK)  
RiksTV AS  
Telonor Broadcast Holding AS  
TV 2 Norge AS  
Elektronikkbransjen

#### Sweden

---

Comhem AB  
Sveriges Television AB (SVT)  
Teracom AB  
ElektronikBranschen

### 2 NorDig Associated Members

The NorDig group represents per June 2014 the following associated members:

Altobeam  
Silicon Laboratories  
Vestel Elektronik Sanayi ve Ticaret A.S.

### 3 Partners

NorDig have had great support from a number of manufactures and other non-NorDig-member companies as technical expertise and with help to ensure updates of our specifications. NorDig would like to express our great appreciation to the following companies for their support in NorDig:

C More  
Digital TV Labs  
Dolby Europe Ltd  
Fraunhofer  
June  
Levira  
LG Electronics  
MTV  
Panasonic  
Samsung Electronics  
Silema  
Sofiadigital  
Sony Europe Ltd  
TP Vision  
Viaplay



## Annex B: NorDig PVR

### 1. CRID Types

A content identifier descriptor can indicate the type of CRID that is carried.

There are 3 types of CRID supported in a NorDig network:

A Programme CRID – to identify a specific piece of content (e.g. programme)

A Series CRID – to group together an arbitrary selection of content (e.g. a series)

A Recommendation CRID – may point to a single event (in programme or series)

CRID types are to be used:

crid\_type :

0x01 Programme CRID

0x02 Series CRID

0x03 Recommendation CRID

**The NorDig PVR should ignore all other CRID types.**

#### 1.1 Programme CRID

##### CRID Type 0x1

Programme CRIDs are used to identify two or more EIT events as being the same programme and may not be used to represent other content defined by the same broadcast authority. This prevents duplicate programmes or repeats being recorded from within the same series and also allows alternative programme instances to be recorded (or offered for recording) if a booking clash occurs.

An EIT event can only be associated with a single programme CRID.

Programme CRID employed on time delay services (+1 hr) must be different and unique from that employed on the live service.

#### 1.2 Series CRID

##### CRID TYPE 0x2

Series CRIDs define groups of programmes linked by the series concept. A CID that describes a Series may contain multiple CRIDs; therefore a Programme may be part of more than one Series. Where an event is associated with more than one series, an invitation to record programmes in the same series as this event would book to record all events in all series associated with the selected event. A PVR shall store and track series CRIDs for up to 13 weeks between occurrences in the EIT schedule. To allow broadcasters to reuse a series CRID for a different editorial concept, IRD's shall discard any series CRIDs not seen in EIT for 13 weeks.

#### 1.2 Recommendation CRID

##### CRID TYPE 0x3

A recommendation may point to a single event (Programme CRID 0x01) or a series (Series CRID 0x02).

A recommendation CRID in the CID shall be marked as CRID type 0x03 (Recommendation) and be a programme or series CRID. It is unnecessary for a recommendation CRID be continually carried within the EIT, if the event being referenced by the recommendation CRID is not present within the current live EIT, the recommendation may be presented to the user when it eventually appears within the EIT.

If a recommendation CRID does not appear within the EIT within 91 days of the referencing event it shall be discarded.

A recommendation may reference an event earlier in the EIT schedule than the linked-from event, e.g. to link to a preview programme.

### 2 Use of the Instance Metadata Identifier

A CRID in the CID shall be a programme CRID (crid type 0x1) with an IMI extension. Where two events have the same CRID and IMI value and the gap between each event is less than 3 hours (measured from the end of the preceding event to the start of the next event) then they shall be considered to be segments of a single item of content.

An item of content may be split across more than two events as long as the gap between each event remains for less than 3 hours.

### 3 CID Carriage

Each Programme described within the EIT p/f and EIT Schedule shall carry in the Event Loop at least one CID that shall contain one CRID of type Programme. Additional CIDs may also be carried in the same Event Loop to describe Groups. A CID that describes a Series may contain multiple CRIDs; therefore, a Programme may be part of more than one Series.

### 4 CRID Encoding

A CRID contained within a Content Identifier Descriptor shall be encoded according to the following rules:

The CRID must be a compliant URI as defined in ETSI TS 102 822-4 [34] section 8.

The CRID is further restricted to only contain characters encoded over the range from ISO 6937 0x20 to 0x7F.

The length of the CRID plus IMI (if any) shall not exceed 64 characters. The maximum lengths of the separate parts of the CRID are as follows:

authority 32 characters (excluding leading `_crid://,`)

data 29 characters (including leading `_/,`)

instance metadata id 3 characters (including `_#,` separator)

The CRIDs are not intended to be humanly readable and shall not be displayed on-screen.

The CRID is split into a number of separate parts:

Given the CRID, **`crid://rtenl.ie/0123ABF#A1`**

Scheme:	<code>crid://</code>	The Scheme describes the format of the rest of the CRID and shall always be “ <code>crid://</code> ”.
Authority	<code>rtenl.ie</code>	The Authority is a registered domain used to represent the source of the content and may be taken from the producer of the content, the broadcaster or other body.
Content	<code>/0123ABF</code>	The Content Identifier uniquely identifies the content within the scope of the current Authority
Instance Identifier	<code>#A1</code>	The Instance Identifier is an optional part that shall be used when a single piece of content

has been split into two (or more) sections.

### **5 Default Authority Descriptor**

A *default\_authority\_descriptor* (0x73) may be placed within the SDT to more efficiently manage the EIT CRID data necessary to support PVR functionality on the network; every service on the network shall be allocated a descriptor. Should the Default Authority Descriptor be carried within the SDT, it is unnecessary for the broadcaster to include the default authority within the CRID.

As described in ETSI TS 102 323 [32], where an event within the EIT does not have a complete URL, the Content Identifier Descriptor (CID) (i.e. a CRID starting with '/'), the NorDig PVR IRD shall:

- Use the default authority (DA) defined for this service within the SDT
- If no default authority is defined within in the SDT, the PVR **shall** use the default authority defined within the second TS loop of the NIT
- If no default authority is defined for the actual transport stream in second loop of the NIT, the receiver shall use default authority in the first loop in NIT for the network that the service belongs to

### **6 Optional Trailer booking/Promotional Linking**

The trailer booking (or promotional linking) is typically used during a promotion trailer to give the viewer the opportunity to easy and directly program/book their PVR to record the event the trailer is referring to.

The PVR supporting Trailer Booking **shall** have the ability to decode and process Related Content Signalling as defined in section 12.8 of NorDig Unified IRD specification (related content descriptor) in order to drive broadcast-triggered native or API based applications typical example Trailer Booking

### **7 Series recording or Series link**

All events that have the same series CRID belongs to the same Series. An individual event inside a Series is referenced here as an Episode. (For definition of CRID, see section 12.4.6. of NorDig Unified IRD specification).

### **8 Complete recording**

The PVR **shall** be capable (at factory default) for all recordings to include all supported components/PID's listed within the PMT of the recorded service *Viz.* Video, Audio 1, Audio 2, Subtitle, Audio Description, Original Language, PCR etc).

If the (HbbTV/MHEG) application in the transmission is signalled as not to be recorded, the NorDig Enhanced and/or Interactive PVR should not record these application streams.

Note: For a NorDig PVR using removable media formats (such as DVD or Blu-ray) for recordings, such devices shall include all supported components/PIDs for that format and any subtitling shall be (according to the user preference settings) be burnt-in to the video or converted into a supported subtitling format.

### **9 Optional Trailer booking/Promotional Linking**

The event name **shall** be displayed together with any promotional text at time of booking (when displaying the Trailer booking menu on screen). At the time of booking, the PVR shall not include any event description text from the short event descriptor.

The short event descriptor's event name (from the RCT) **shall** be used to provide information about the event in the PVR list of booked recordings. The extended event descriptor's event description text from EIT may also be used in the PVR list of booked recordings to provide information.

## **10 Series recording or Series link**

The PVR **shall** be able to record a complete Series via the CRID.

The PVR **shall** store and track series CRIDs that are programmed for recording for up to 91 days between occurrences in EIT schedule. To allow broadcasters to reuse a series CRID for a different editorial concept, the NorDig PVR shall discard any series CRIDs not seen in EIT for 91 days.

The display of programmes selected for recording shall include an indication if the programme is included as a consequence of being one of a series.

The IRD should be aware that the default authority may be changed over time (for example a service might have default authority added in SDT); the NorDig PVR should automatically update its stored default authorities (not only during installation) within fifteen minutes from reception.

### **10.1 Series record for all episodes**

The PVR **shall** support recording of all episodes of a specific series via series CRID in the broadcast transport stream.

It **shall** be possible for the viewer from EPG to program the PVR to record a series of events. The PVR shall indicate in the EPG that an event is part of a series and the PVR shall, if the user selects to record the event that belongs to a series, request the user to confirm what to record:

1. Only the single event selected.
2. Several or All events (episodes) of the series

#### **10.1.1 Series record limited to a number of episodes for a series**

The PVR should support recording of a (limited) number of episodes of a specific series via series tagging in the broadcast. The limitation should either be a period of time or a specific number of episodes.

#### **10.1.2 Series, only one instance/copy of each episode**

The PVR should support the feature to only record one instance/copy of each episode in a series for series recording, in order to more efficiently handle to handle repeat programming.

## **11 Split recording**

A programme may consist of multiple EIT events within the same service or over several services. i.e. a film might be divided into two parts/blocks interrupted by a news programme in the middle (see fig 1 -A) or a longer sport event might be split into several parts/blocks over several services, (see fig 1-B).

Signalling carried in the SI allows the PVR to identify and record all the events containing the parts of a single programme. A “split programme” is a single piece of content, which comprises of two or more EIT events having the same CRID and IMI value with the gap from the scheduled end time (start\_time plus duration) to the scheduled start time of any two of those events is less than 3 hours.

The PVR **shall** consider a split programme to be segments of a single item of content. When selecting a split programme for recording, the PVR shall select and record all constituent events so that the complete programme content is recorded.

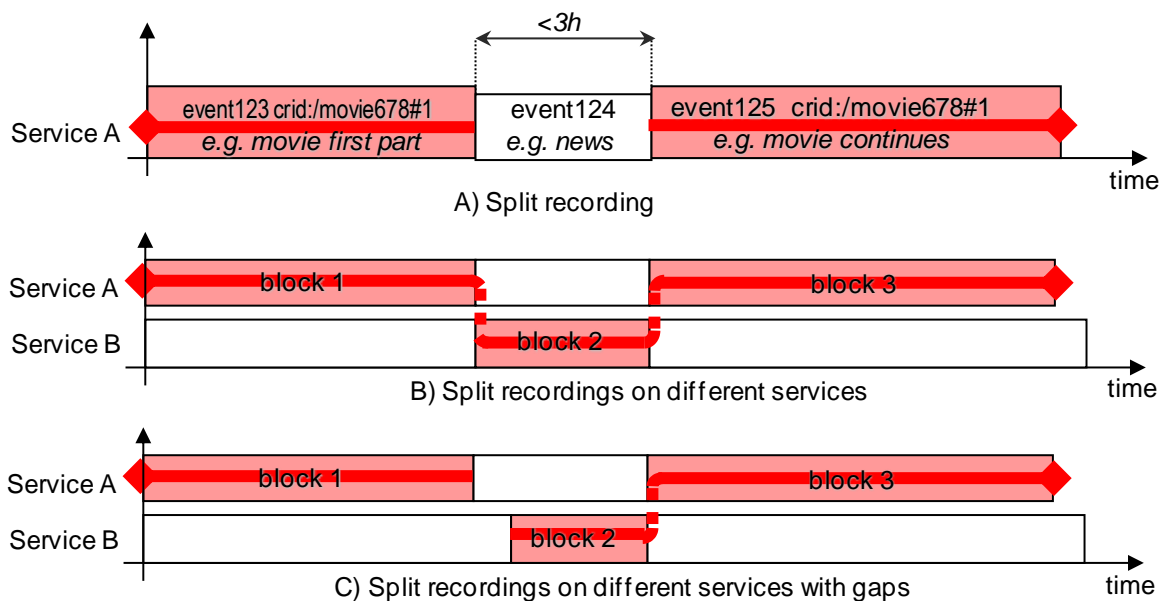

*Table A1: Handling of split recordings by the PVR. Split programme events (events with the same CRID value that are broadcast close in time to each other) shall be recorded with one and the same programming by the PVR.*

- A) The maximum gap time between events with the same programme CRID value that shall still be treated as belonging to the same programme for recording.
- B) Split programme over several services.
- C) Split programme with gap and over separate services

There are cases where a PVR may during the time of programming a recording only see a single event with the booked CRID and IMI combination (for example initially only the first part/block of the split programme has so far been included in the EIT). The PVR shall continue to monitor the EIT for additional events with the same CRID and IMI combination and include them to the selected recording.

In case of overlap between the split events and if the PVR has limitation in recording capacity when back-to-back recording, then the PVR **shall** first finalise recording of the first part or event of the split programme (according to the events start time and duration) before starting to record the next part of the split programme, this is the same behaviour as back-to-back recordings.

During the lifecycle of the EIT schedule, broadcasters may change programmes from split to single or vice versa.

In the PVR split recordings **shall** clearly be marked in the list of recordings as constituent parts belonging to the same programme, for example as one and the same entity or similar. It shall be enough to select only one entity from the file list of recording to get a playback of the complete programme, including all constituent events.

## 12 Safe margins

The PVR **shall** have a factory default safe margin setting of one minute before the events start time and five minutes after the event is no longer present. The margin before the event start time shall be based on the latest possible EIT update. For safe margin, recording the PVR should insert index markers into the recording when the event status changes to running and another when the event becomes not running. It shall be possible via the set-up or configuration menu to deactivate safe margin settings.

As a default, setting safe margins shall have a lower priority than any back to back recording.

### **13 Presentation and management of scheduled recordings**

The PVR at all times keep track of future scheduled recordings, the PVR **shall** present to the user all scheduled recordings on one screen (manual single, manual repeated and series).

For scheduled series recordings, the PVR **shall** present to the user all future scheduled instances of the series that can be detected from the broadcast EIT data.

The user shall be able to delete any future scheduled recording. The user **shall** be able to delete one individual scheduled recording belonging to a series without deleting the series.

### **14 Presentation and management of acquired recordings**

In addition to NorDig Unified IRD specification the user **shall** be able to view a list of acquired recordings where all episodes of a series are grouped into the same item on the list and displayed as such. Series items should be marked for the user that the item includes several episodes or events. Each such item representing a group of recorded series **shall** be expandable on request by the user so that all recorded episodes are displayed.

### **15 Cache in background**

The PVR **shall** support during normal viewing mode monitor and cache all EIT section data including EIT present/following, EIT schedule and EIT other as a background function. The PVR **shall** update its cached EIT data for any dynamic changes in the EIT broadcast data. To improve presentation of EPG data after start up, the PVR should store the most up to date cache of EIT data to the PVR persistent memory (HDD).

**For more information see NorDig Unified IRD specification and “NorDig PVR metadata Whitepaper version 1.0”.**

## Annex C: AC-4 Audio (informative)

An AC-4 bitstream consists of synchronisation frames, each beginning with a sync word and optionally ending with a cyclic redundancy check (CRC) word. The sync word allows a decoder to easily identify frame boundaries and begin decoding. The CRC word allows a decoder to detect the occurrence of bitstream errors and perform error concealment when it detects an error.

The data carried within each synchronisation frame is referred to as the raw AC-4 frame. Each raw frame contains a Table of Contents (TOC) and at least one sub stream containing audio and related metadata. Figure 5 shows the high-level bitstream structure.

### High-level bitstream syntax for AC-4 (Part 2)

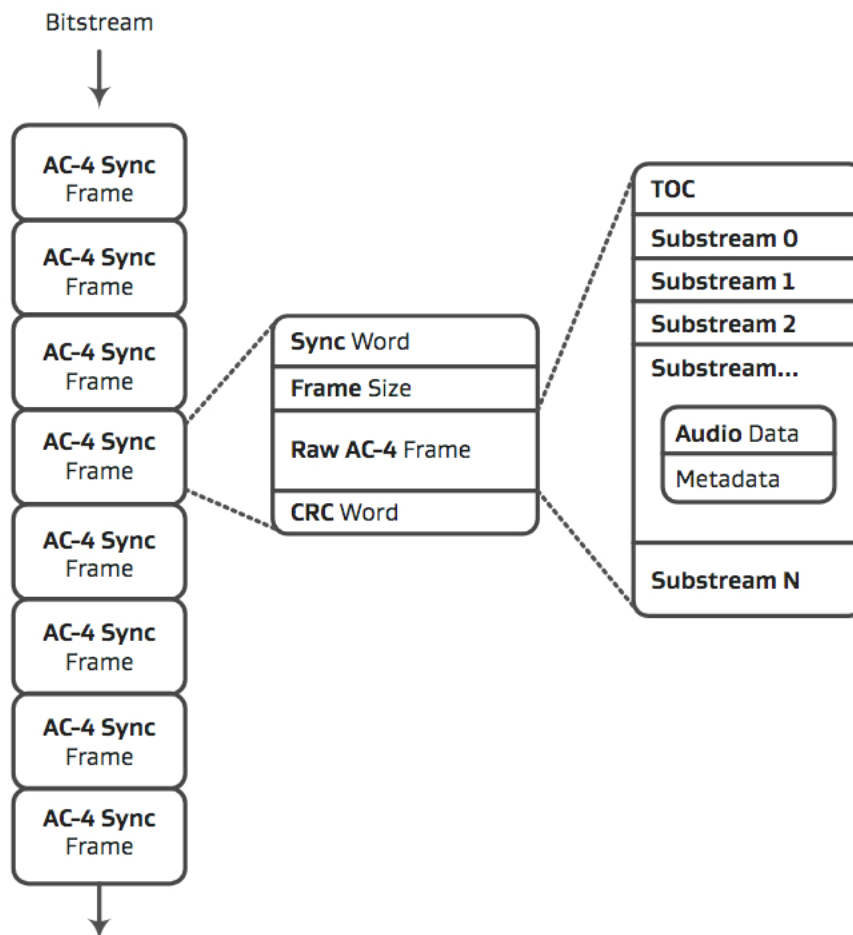

Figure C1: High-level bitstream syntax for AC-4 (Part 2).

The TOC contains the inventory of the bitstream. Each audio substream can carry either one or more audio channels or an individual audio object. This structure provides flexibility and extensibility that allows the AC-4 format to meet future requirements.

AC-4 also allows multiple Presentations to be carried in a single bitstream. Each Presentation defines a way of mixing a set of audio substreams to create a unique rendering of the program. Instructions for

which substreams to use and how to combine them for each Presentation are specified in a Presentation info element carried in the TOC.

Presentations enable multiple versions of the audio experience, such as different languages or commentary, to be delivered in a single bitstream in a convenient, bandwidth-efficient manner. An example is shown in Figure 6 below, where four versions of a live 5.1 sports broadcast—the original English version, two alternate languages (Spanish and Mandarin Chinese), and a commentary-free version—are combined into a single AC-4 bitstream.

### Live 5.1 sports broadcast with four presentations

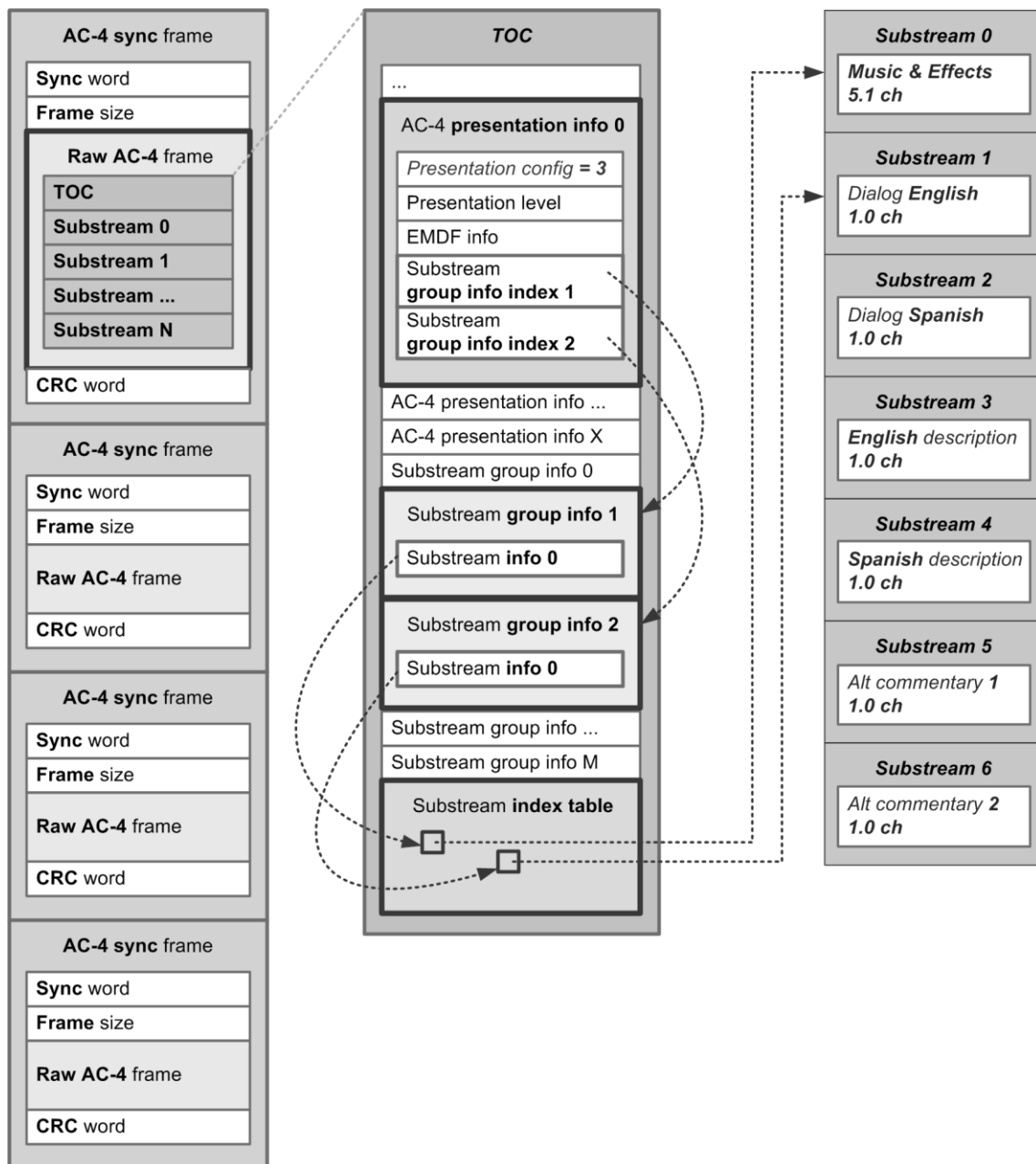

Figure C2: Live 5.1 sports broadcast with four presentations.



### **Multi language application**

AC-4 provides native support for multi-lingual applications as described above.

### **Audio description application**

AC-4 provides native support for description services in a similar manner to multiple language support. This can be used to selectively mix descriptive commentary over the main audio in the receiver where desired.

### **Dialogue Enhancement**

Surveys have highlighted that an aspect of NGA that is particularly valued by consumers is the potential for greater dialogue clarity. Industry conversations and research work showed that the ability to enhance dialogue reproduction will be a fundamental advantage of NGA services.

As a result, a principle applied in the implementation of AC-4 solutions is that the dialogue enhancement feature on the IRD should work for all AC-4 content, whether or not a separate dialogue has been provided to the encoder.

When dialogue signals are not separately available to the AC-4 encoder, the encoder runs an algorithm to extract the dialogue from the audio mix. The AC-4 decoder provides a control to set the strength of dialogue enhancement or turn it off and leave the content unchanged.

AC-4 supports different ways of embedding dialogue enhancement metadata:

- Using parametric dialogue enhancement provides a very efficient transmission of dialogue enhancement data, allowing it for low bit rate applications with traditional channel-based content. The transmission of a dialogue audio object is not required. The metadata for parametric dialogue enhancement can be generated from a separate dialogue input (guided dialogue enhancement, Figure A.1) or, if that is not present, the encoder extracts them itself (unguided dialogue enhancement, Figure A.2). For guided dialogue enhancement, a third-party dialogue extractor can be used.
- The best audio quality can be achieved by sending the dialogue as a separate object (see Figure A.3). It is also the most costly option in terms of bit rate. This option requires the dialogue to be kept separate during the production.
- Hybrid dialogue enhancement is a compromise of the two methods above. It is based on parametric dialogue enhancement, but it allows to improve the quality of the dialogue enhancement further by sending a low bit rate version of the original dialogue object along with the parametric representation. The dialogue enhancement quality largely depends on the quality of that dialogue object as input to the analysis.

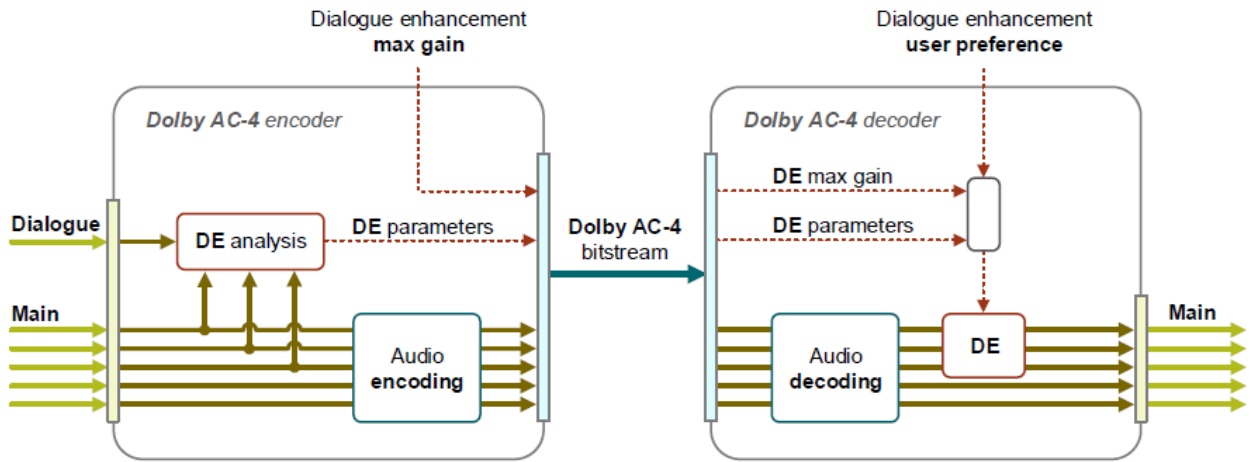

Figure C3: Parametric Dialogue Enhancement using Guided Dialogue Enhancement Analysis

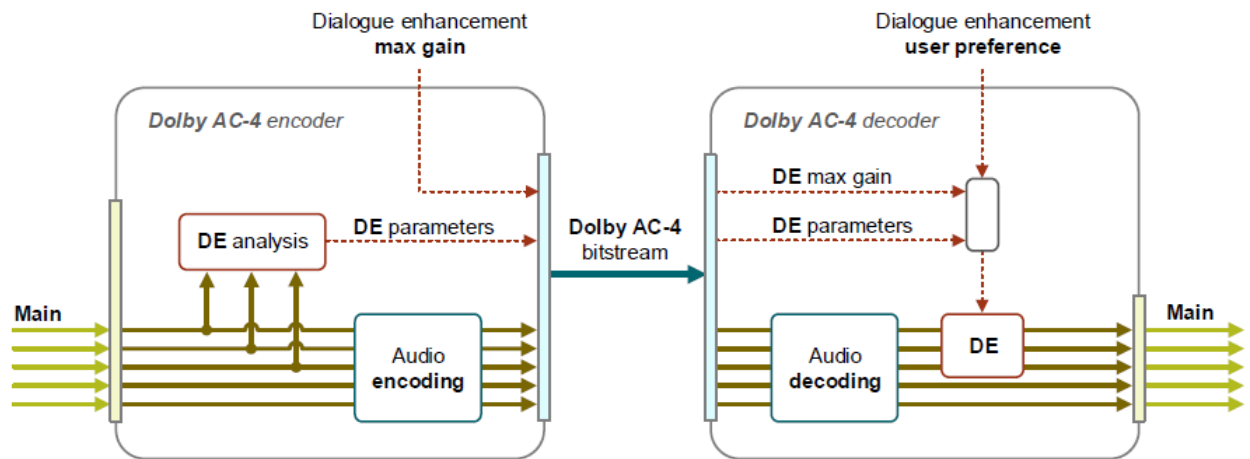

Figure C4: Parametric Dialogue Enhancement using Unguided Dialogue Enhancement Analysis

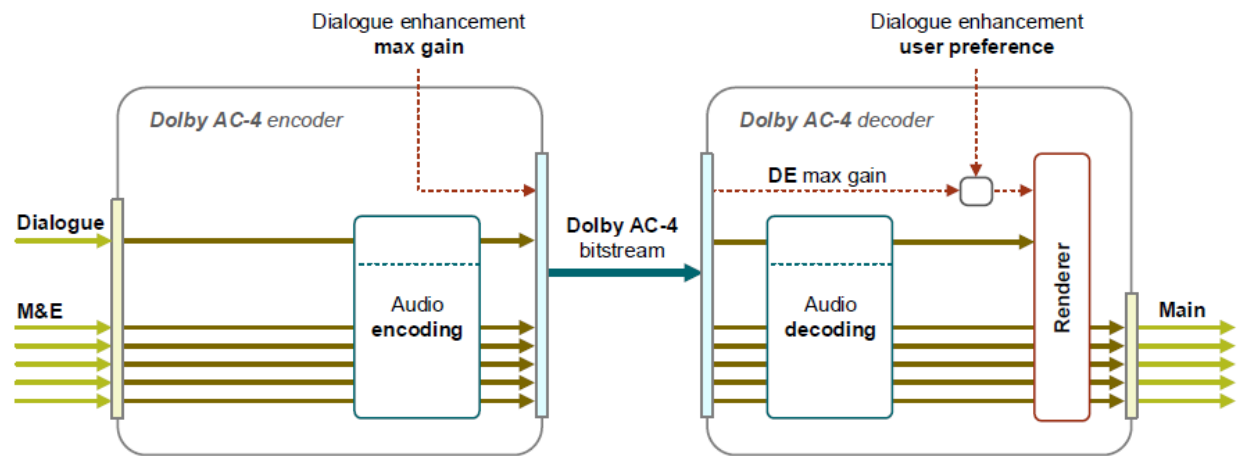

Figure C5: Waveform Dialogue Enhancement using dedicated dialogue objects or channels.

The broadcaster control is realized by setting or clearing the Dialogue Enhancement Present Flag (`b_de_data_present`), and if dialogue enhancement is enabled setting a Dialogue Enhancement Maximum Gain in the range of 3 to 12 dB, in 3 dB steps. The Dialogue Enhancement Maximum Gain (called `de_max_gain` or `dialog_max_gain`, depending on the dialogue enhancement method) limits the amount of boost that a user can apply in the decoder.

## Annex D: Old text from RoO ver. 2.5 – chapter 3 The modulators and tuners of NorDig Broadcaster

### 3.5 Tuning and Navigation

The tuning of the NorDig set-top box can either be based on Network Information Table (NIT) signalling within SI or on scanning. The receiver shall identify a service uniquely through a combination of *original\_network\_id* (ONID) and *service\_id* (SID). Tuning based on NIT information is detailed below.

### 3.6 DVB specific identifiers

Each service shall be uniquely identified through the combination *original\_network\_id* (ONID) *transport\_stream\_id* (TSID) *service\_id* (SID) also known as the DVB triplet . These, and some other mandatory parameters, are described in the following sections.

#### 3.6.1 Original\_network\_id

Each network operator originating broadcasting signals shall apply for a 2-byte *original\_network\_id* according to ETSI TR 101 162.

Country	ONID	Network ID
Denmark	0x20D0	Colour plan C (0x3201 ~ 0x3300)
Finland	0x20F6	Colour plan D (0x3301 ~ 0x3400)
Iceland	0x2160	Colour plan D (0x3301 ~ 0x3400)
Ireland	0x2174	Colour plan C (0x3201 ~ 0x3300)
Norway	0x2242	Colour plan E (0x3401 ~ 0x3500)
Sweden	0x22F1	Colour plan B (0x3101 ~ 0x3200)

Table 8: DVB identifiers

#### 3.6.2 Network\_id

Each NorDig network operator broadcasts a number of transport streams, each stream is considered as part of that specific network and shall identify uniquely its self by *network\_id*. The allocation of *network\_id* is carried out by ETSI, and allocated values are available in the ETSI document TR 101 162 and as detailed in Table 8.

For terrestrial networks a unique *network\_id* shall be allocated to each Local Service Network (LSN) in the national network. The allocation shall comply to the ETSI TR 101 162 4-colour-map approach, this gives the possibility to allocate up to 256 *network\_ids* within the network.

#### 3.6.3 Transport\_stream\_id

The *transport\_stream\_id* shall uniquely define a transport stream within the network comprising of a specific combination of services and components. Each multiplex operator shall allocate a *transport\_stream\_id* on an individual basis however all transport streams within a network should carry a unique identifier.

### 3.6.4 Service\_id

The *service\_id* shall identify all unique services carried by the multiplex operator on the network.

A service is considered unique if its service name, scheduled events and service components are different to any other service components on the network.

The *service\_id* is equivalent to the *program\_number* used in PAT and PMT.

### 3.6.5 Private\_data\_specifier

A NorDig allocated *private\_data\_specifier* 0x00000029 shall be inserted within the *private\_data\_descriptor* prior to all NorDig Specific signalling e.g. LCN v1 or v1

Country	private_data_specifier
Denmark	0x00000031
Finland	-
Iceland	0x00002160
Ireland	0x000022CE
Norway	0x00000030
Sweden	0x000022F1

Table 9: Country specific specifier values

A country specific *private\_data\_specifier* shall be inserted within the *private\_data\_descriptor* prior to all country specific signalling.

### 3.6.6 Bouquet\_id

One or several *bouquet\_ids* shall be allocated to each service provider. The following general rules are applicable:

- i) A service provider shall not allocate more *bouquet\_ids* than it has services to offer.
- ii) Each service should be presented in one and only one bouquet.
- iii) A service provider can group several services into one bouquet.
- iv) A bouquet (with an associated *bouquet\_id*) may contain services from different service providers.
- v) The *bouquet\_id* is static and cannot change in time.

*bouquet\_id* registration is the responsibility of the service provider.

### 3.6.7 Event\_id

The *event\_id* is a 16-bit field which contains the identification number of the described event. Each service provider is free to allocate *event\_ids* within their *service\_id* domain, with the restriction that an *event\_id* shall be unique within the transmitted schedule. An *event\_id* shall be associated with a single event within the schedule, i.e. if an event is rescheduled within the currently transmitted schedule, it shall not change its *event\_id*. If the event is removed from the schedule (or rescheduled to outside the

transmitted schedule) then its *event\_id* shall be removed from the schedule. Any replacement event shall be allocated a new *event\_id* unique within the transmitted schedule.

A recommended allocation method for new *event\_id* in terrestrial networks is to use odd values for national events and even values for regional events, this to avoid that events that are inserted at different locations will be allocated the same *event\_id*.

The *event\_id* shall be included in the following EIT tables;

EIT\_actual\_p/f

EIT\_other\_p/f

EIT\_actual\_schedule

EIT\_other\_schedule

### 3.6.8 Link to EIT schedule

Generally, the linkage to the EIT schedule is implemented by inserting a *linkage\_descriptor* in the first descriptor loop in the NIT. Linkage\_type 0x04 is used for this purpose.

A problem can occur whenever multiple operators offer services from the same satellite transponder. This is best illustrated by the following example:

One satellite network which we will call *X-sat* consists of 4 transport streams, there are two independent operators managing transport streams on this satellite according to the following rule:

- TS1 - transport\_stream\_id 0x0001: operated by "Operator A"
- TS2 - transport\_stream\_id 0x0002: operated by "Operator A"
- TS3 - transport\_stream\_id 0x0003: operated by "Operator B"
- TS4 - transport\_stream\_id 0x0004: operated by "Operator B"

The *network\_id* of *X-sat* is 0x0040, while the *original\_network\_id* of Operator A and Operator B is 0x0041 and 0x0051 respectively. Operator A transmit their EIT schedule information in TS 1, while Operator B transmit their EIT schedule information in TS 3.

**TS 5 contains 5 services split between "Operator A" and "Operator B" as indicated in Table 10:**

Service	Service_id	Commercial operator
Service 1	0x0101	"Operator A"

Service 2	0x0102	"Operator A"
Service 3	0x0103	"Operator A"
Service 4	0x0104	"Operator B"
Service 5	0x0105	"Operator B"

Table 10: Services in TS 5

Subscriber A has subscribed for the services from Operator A; they access Service 1 and select the Guide button, with this action subscriber A expects to access the EIT schedule provided by Operator A and transmitted in TS 2.

Subscriber B has subscribed to the services from Operator B; they access Service 4 and select the Guide button, subscriber B expects to access the EIT schedule for Operator B transmitted in TS 3.

Accessing different EIT schedule services on the same transponder cannot be achieved by inserting *linkage\_descriptors* within the NIT, this is resolved by employing the *bouquet\_association\_table*. The BAT shall contain bouquet associations for both for Operator A and for Operator B as indicated in Figure 5

Note: each operator has to apply for a unique bouquet\_id from ETSI. The document TR 101 162-ETSI indicates available values for the bouquet\_id. In this example we have for illustrative purposes assumed that the bouquet\_id for Operator A and Operator B is 0x0001 and 0x0002, respectively.

```

bouquet_association_section(){
    table_id                0x4A
    bouquet_id              0x0001 ("Operator A")

    #bouquet descriptors{
        bouquet_name_descriptor(){
            bouquet_name      "Operator A"
        }
        linkage_descriptor(){
            transport_stream_id 0x0002
            original_network_id 0x0041
            service_id
            linkage_type        0x04
        }
    }
}

```

```

    }
    # transport stream loop{
        transport_stream_id          0x0001
        original_network_id          0x0041
        #transport stream descriptors{
            service_list_descriptor(){
                <all services in TS1>
            }
        transport_stream_id          0x0002
        original_network_id          0x0041
        #transport stream descriptors{
            service_list_descriptor(){
                <all services in TS2>
            }
        transport_stream_id          0x0005
        original_network_id          0x0041
        #transport stream descriptors{
            service_list_descriptor(){
                service_id            0x0101
                service_type          digital television
                service_id            0x0102
                service_type          digital television
                service_id            0x0103
                service_type          digital television
            }
        }
    }
}

bouquet_association_section(){
    table_id                        0x4A
    bouquet_id                      0x0002 ("Operator B")
}

```



```
#bouquet descriptors{
    bouquet_name_descriptor(){
        bouquet_name      "Operator B"
    }
    linkage_descriptor(){
        transport_stream_id  0x0003
        original_network_id  0x0051
        service_id
        linkage_type         0x04
    }
}
# transport stream loop{
    transport_stream_id      0x0003
    original_network_id      0x0051
    #transport stream descriptors{
        service_list_descriptor(){
            <all services in TS3>
        }
    }
}
```

```
transport_stream_id      0x0004
original_network_id      0x0051
#transport stream descriptors{
    service_list_descriptor(){
        <all services in TS4>
    }
}
transport_stream_id      0x0005
original_network_id      0x0041
#transport stream descriptors{
    service_list_descriptor(){
        service_id          0x0104
        service_type       digital television
        service_id          0x0105
    }
}
```

```

                                service_type    digital television
                                }
                                }
                                }
}

```

**Figure 8: BAT containing bouquets for both operators**

Note: that in each bouquet, the *service\_list\_descriptor* for TS 5 contains only the services from the corresponding commercial operator.

**The set-top box is advised to access EIT schedule according to the following algorithm:**

```

If linkage_descriptor in first descriptor loop in NIT
{
  If linkage_type = 0x04
  {
    Tune to Barker Channel;
    Read EIT
  }
}
Else
{
  Find the BAT subtable containing the last accessed service;
  Read linkage_descriptor;
  If linkage_type = 0x04
  {
    Tune to Barker Channel;
    Read EIT
  }
}

```

**Figure 9: EIT schedule algorithm**

It might be the case in secondary distribution networks that only a subset of the services from the primary distribution network will be available. Both PAT and SDT in the secondary distribution network may signal more services than are actually available. The native service navigator, i.e. ESG, shall not display any service that the receiver cannot receive, due to the fact that it is not retransmitted from primary distribution network. A service is available whenever it is included in the *service\_list\_descriptor* in the NIT for the appropriate network.

**The receiver shall decide whether a service shall be presented in the native service navigator by the following algorithm:**

```
If service_id is available in any service_list_descriptor in the appropriate NIT
{
    display the service in the (ESG/EPG )
else
    do not display the service
}
```

Figure 10: Native service navigator algorithm

The same algorithm shall be used in terrestrial receivers to “hide” services not accessible due to low RF level.

### 3.7 Specific tuning for Satellite Networks

#### 3.7.1 Multiple operators in the same physical network

One physical network (orbital satellite position) may be shared between multiple operators, e.g. each operator manages different transponders in the same physical network.

On satellite networks, NIT\_actual on each transponder shall describe all transport streams operated by the operator of the actual transport stream as well as all transport streams operated by other operators in the same satellite network. NIT\_other may describe transport streams operated by any other operator in another network (i.e. retransmission into secondary networks).

The principle of multiple operators in the same satellite network is best illustrated by an example.

One satellite network *X-sat* consists of 4 transport streams. There are two independent operators managing these transport streams according to the following rule:

- TS1 - transport\_stream\_id 0x0001: operated by "Operator A"

- TS2 - transport\_stream\_id 0x0002: operated by "Operator A"
- TS3 - transport\_stream\_id 0x0003: operated by "Operator B"
- TS4 - transport\_stream\_id 0x0004: operated by "Operator B"

The *network\_id* of *X-sat* is 0x0040, the *original\_network\_id* of Operator A and Operator B is 0x0041 and 0x0051 respectively. Operator A transmit their EIT schedule information in TS 1, whilst Operator B transmit their EIT schedule information in TS 3.

The network operator ("X-sat") is responsible for NIT generation and all transport streams are signalled in *NIT\_actual*, both from Operator A and Operator B.

**An example of the NIT transmitted in all transport streams is shown in Figure 11:**

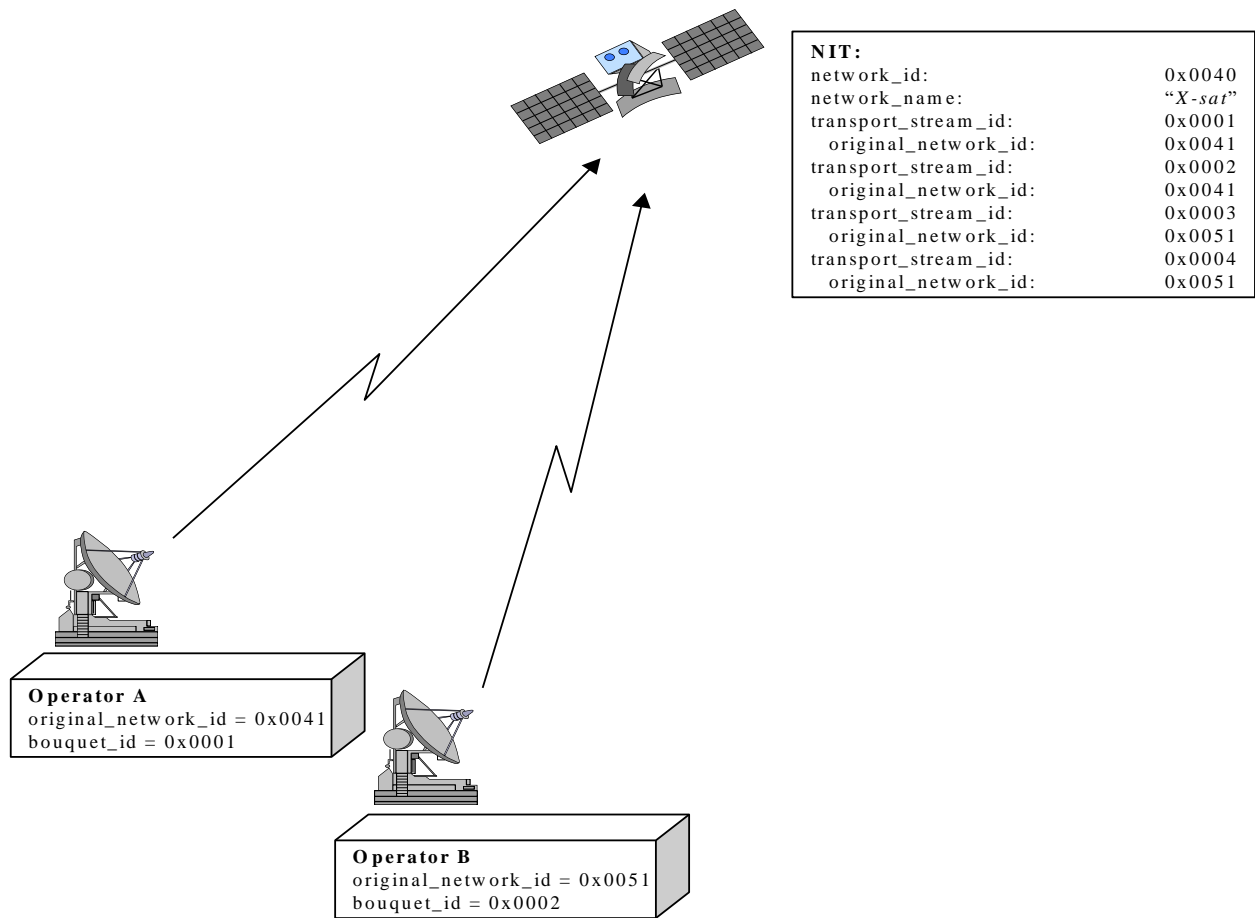

Figure 11: NIT transmission with multiple operators

```
network_information_section(){
  table_id0x40      (NIT_actual)
  network_id      0x0040 (X-sat)
  #first loop descriptors{
    network_name_descriptor(){
      network_name "X-sat"
    }
    linkage_descriptor(){ # link to NorDig software
      download
      transport_stream_id 0x0001
      original_network_id 0x0041
      service_id          0x000A
      linkage_type        0x81
      private_data        <according to NorDig
      specification>
    }
  }
  #transport stream definitions{
    transport_stream_id 0x0001
    original_network_id 0x0041 (Operator A)
    #second loop descriptors{
      satellite_delivery_system_descriptor()
      service_list_descriptor()
    }
    transport_stream_id 0x0002
    original_network_id 0x0041 (Operator A)
    #second loop descriptors{
      satellite_delivery_system_descriptor()
      service_list_descriptor()
    }
    transport_stream_id 0x0003
    original_network_id 0x0051 (Operator B)
    #second loop descriptors{
```

```

        satellite_delivery_system_descriptor()
        service_list_descriptor()
    }
    transport_stream_id          0x0004
    original_network_id          0x0051 (Operator B)
    #second loop descriptors{
        satellite_delivery_system_descriptor()
        service_list_descriptor()
    }
}

```

**Figure 12: Example of NIT from "X-sat"**

### 3.7.2 Set-top box interpretation

For satellite transmission a valid *NIT\_actual* should always be transmitted. Satellite front end software may ignore *NIT\_other* and focus on *NIT\_actual*. Parameters of a default transponder have to be entered manually by the subscribers or may be pre-programmed from the set-top box manufacturer.

## 3.8 Specific tuning for cable networks

Cable operators may use both *NIT\_actual* and *NIT\_other* for two specific reasons:

1. Cable operators often distribute signals to several subnets located in different geographical areas. The *network\_id* is used to distinguish between these subnets.
2. Cable operators retransmitting signals received from satellite may insert the receive network information as *NIT\_other*.

### 3.8.1 Transmission of multiple *NIT\_other* tables

Cable operators must be able to provide multiple NIT tables for different networks. The NorDig receiver should provide a menu for the user to enter the network number of the physical network it is connected to.

The following example has been chosen to illustrate this:

The satellite network *X-sat* transmits *NIT\_actual* containing network information for the satellite network. In addition, *NIT\_other* from *X-sat* contains network information for the following SMATV operators:

- SMATV A: *network\_id* = 0x0090
- SMATV B: *network\_id* = 0x0091

The following transport streams are transmitted in SMATV A:

- TS1 – transport\_stream\_id = 0x0001
- TS2 – transport\_stream\_id = 0x0002

The following transport streams are transmitted in SMATV B:

- TS3 – transport\_stream\_id = 0x0001
- TS4 – transport\_stream\_id = 0x0002

**The NIT transmitted via satellite is indicated in Figure 8**

```

network_information_section(){
    table_id0x40          (NIT_actual)
    network_id    0x0040 (X-sat)
    #first loop descriptors{
        network_name_descriptor(){
            network_name "X-sat"
        }
        linkage_descriptor(){ # link to NorDig software
            download
            transport_stream_id    0x0001
            original_network_id    0x0041
            service_id              0x000A
            linkage_type            0x81
            private_data            <according to NorDig
                                   specification>
        }
    }
    #transport stream definitions{
        <Definition of transport streams in satellite network>
    }
}

network_information_section(){
    table_id0x41          (NIT_other)
    network_id    0x0090 (SMATV A)
    #first loop descriptors{
        network_name_descriptor(){
            network_name "SMATV A"
        }
    }
}

```



```

    }
    linkage_descriptor(){ # link to NorDig software
        download

        transport_stream_id    0x0001
        original_network_id    0x0040
        service_id              0x000A
        linkage_type            0x81
        private_data            <according to NorDig
                                specification>
    }
}

#transport stream definitions{
    transport_stream_id        0x0001
    original_network_id        0x0040
    #second loop descriptors{
        satellite_delivery_system_descriptor()
        service_list_descriptor()
    }
    transport_stream_id        0x0002
    original_network_id        0x0040
    #second loop descriptors{
        satellite_delivery_system_descriptor()
        service_list_descriptor()
    }
}

network_information_section(){
    table_id0x41              (NIT_other)
    network_id                0x0091 (SMATV B)
    #first loop descriptors{
        network_name_descriptor(){
            network_name      "SMATV B"
        }
    }
}

```

```

linkage_descriptor(){ # link to NorDig software
    download
    transport_stream_id    0x0001
    original_network_id    0x0040
    service_id              0x000A
    linkage_type            0x81
    private_data            <according to NorDig
                           specification>
}
}
#transport stream definitions{
    transport_stream_id    0x0001
    original_network_id    0x0040
    #second loop descriptors{
        satellite_delivery_system_descriptor()
        service_list_descriptor()
    }
    transport_stream_id    0x0002
    original_network_id    0x0040
    #second loop descriptors{
        satellite_delivery_system_descriptor()
        service_list_descriptor()
    }
}

```

**Figure 13: Satellite NIT transmission including NIT other**

### 3.8.2 Set-top box interpretation

For cable set-top boxes the parameters of the “barker channel” shall either be entered manually from the subscriber or pre-programmed by the set-top box manufacturer. Along with the “barker channel” parameters, the set-top box shall ask the subscriber to enter the appropriate network number.

**When the subscriber initiates channel search, the set-top box may perform a search according to the following algorithm:**

```

Access the “barker channel” NIT;
For all network_ids in NIT_actual and NIT_other{
    If network_id = network number{

```

```

# Correct NIT section detected
For all transport streams defined in NIT section{
    Read cable_delivery_system_descriptor;
    Read service_list_descriptor,
    Tune to the transport stream;
    Read SDT;
    Present all service names for which service_id is
    included in service_list_descriptor;
}
}
}

```

**Figure 14: Barker channel algorithm**

### 3.9 Specific tuning for Terrestrial Networks

Terrestrial transmission is somewhat different from both satellite and cable transmission due to several reasons, particularly the following two:

- One network operator may cover the same geographical area from several transmitters, i.e. the same services may be received from different transmitters.
- The network may offer regional signals, i.e. signals receivable only in a part of the total network.

Due to these reasons, some special precautions have to be taken for terrestrial transmission. The following sections identify these precautions.

#### 3.9.1 Definition of terrestrial network concepts

**MFN:** Multiple Frequency Network is a network that over a specified area transmits with several different frequencies and thereby has the possibility to transmit different transport streams over that area. This property is what we in this document call a **Scalable Network (SN)**.

**Preference Network:** Can be seen as the main network of a viewer in an intersection area of several networks, this network is usually chosen by the user during installation of the STB.

**SFN:** Single Frequency Network is a network where one transport stream is feeding several main-transmitters all transmitting on the same frequency. The transport stream has to be identical in all main-transmitters. This property, that the transport stream is identical over a bigger region, is what we have called a **Non**

**Scalable Network (NSN)** in this document. A NSN can be caused by a SFN or that only one multiplexer is feeding several frequencies.

### 3.9.2 Cross-Carriage of SI

It should always be possible to present all services and events (present and following) to the viewer, which the viewer has the possibility to receive within a Local Service Network (see below). This requires that all SI is cross-distributed over all frequencies in that specific region. The cross-carriage of SI is limited to the finest level of regionality, called a Local Service Network (LSN). The Local Service Network can be defined as the coverage area of a transport stream, i.e. if several transport streams cover exactly the same area they belong to the same Local Service Network. The cross carriage shall be limited within the Local Service Networks with the exception of region who have a mixture of SFN and MFN.

The navigation EPG/ESG, shall not display any service that the receiver can not receive, due to low RF level or status.

The definition that a service is possible to receive is that it is included in the *service\_list\_descriptor* in a received NIT\_actual table. By using this definition the receiver can by a very simple algorithm decide whether or not to present the cross distributed service.

If Service\_id is available in any received NIT\_actual (*service\_list\_descriptor*)

display the service in the (EPG/ESG )

if not available

do not display the service

- The receiver shall only display a service once, even if the same service is received from multiple transmitters, the receiver shall choose the service belonging to the preferred network.

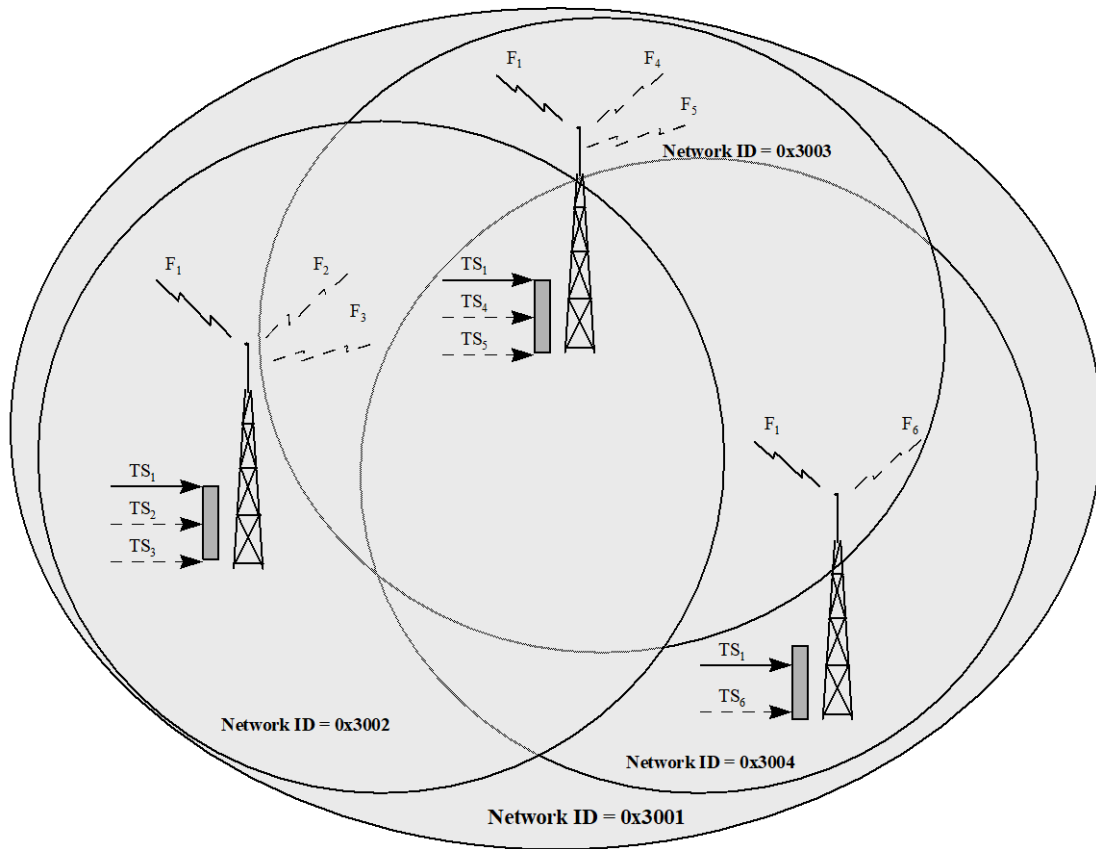

Figure 15: an example of the mixture of Multiple- and Single Frequency Networks

Due to limited bandwidth in the terrestrial network the cross distribution of the SI shall be limited to the following tables:

- All BAT sub tables for the LSN.
- SDT other for all services in the LSN, i.e. listed in the NIT (actual)
- EIT other (present and following) for all services listed within each SDT other. The EIT\_present\_following\_flag shall be set to "1", which indicates that the EIT\_present\_following information for the services is present in the current TS.

The LSN can for the purpose of SI be treated as a single terrestrial network unique within the network.

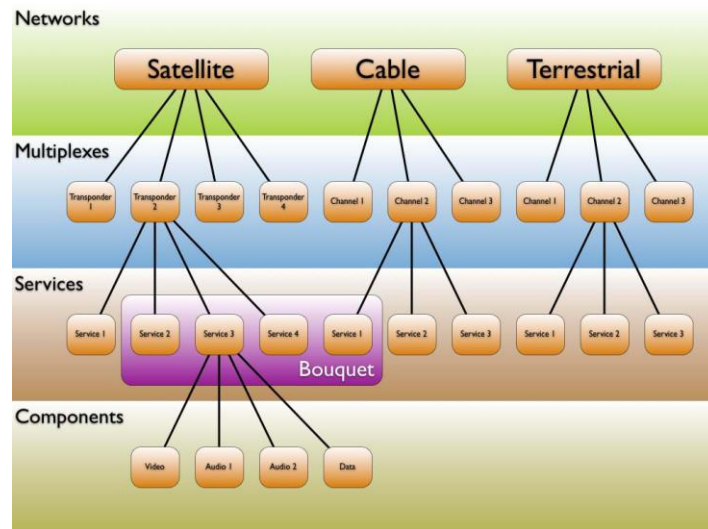

Figure 16: DVB service delivery model

The delivery system model is detailed in Figure 16; this restriction is to optimise the use of the bandwidth within the terrestrial network. Depending on aerial installation and receiver location, a receiver may be able to receive multiplexes from more than one LSN. There is normally no cross-carriage of SI specified between LSN, and the receiver must therefore treat the LSN as independent networks. However, where a receiver finds the same combination of `original_network_id` / `service_id` in multiplexes received from different LSN the services may be considered to be identical.

As specified above there is an exception to the rule of no cross-distribution between LSN. The cross-distribution in the case of mixture of SFN and MFN will be limited to the SFN. The best way to explain this is probably by example:

One multiplexer (TS 1) is feeding three main-transmitters all transmitting on the same frequency (F 1) in a regional Single Frequency Network. Each of these transmitter nodes has other transmitters that are transmitting on the frequencies F 2, F 3, F 4, F 5 and F 6. These three local transmitters are fed by their own multiplexer transport streams TS 2, TS 3, TS 4, TS 5 and TS 6 respectively.

All the transport streams covering the same regional network will cross-distribute the SI between them, just as previously discussed. However, the SFN that covers several LSN will cross-distribute the SI from all the LSN area that it covers and the SI from the SFN is likewise cross-distributed to the MFN.

**An overview of the Network Information Tables for TS 1 and TS 2 in our example is described below:**

**For TS 1:**

```
Network_information_section() {
    table_id      0x40 ( actual )
    network_id    0x3001
    transport_stream_id  0x0001
```

```

    {
        list of services
    }

```

```

network_information_section() {
    table_id      0x41 ( other )
    network_id    0x3002; 0x3003; 0x0004 (one for each NIT other table)
    ↓           ↓           ↓
    transport_stream_id 0x0002 -3;0x0004-5; 0x0006 (for each NIT other table)
    {
        list of services
    }

```

**For TS 2:**

```

network_information_section() {
    table_id      0x40 ( actual )
    network_id    0x3002
    transport_stream_id 0x0002-3
    {
        list of services
    }

```

```

network_information_section() {
    table_id      0x41 ( other )
    network_id    0x3001
    transport_stream_id 0x0001
    {
        list of services
    }

```