



5G RECORDS



UC2 multicamera 5G S-NPN production demo

Copenhagen, 29th June 2022

TIVOLI live demo

Wednesday 29th June CET15:00-16:00

Concept

The ambition is to get as close as possible to a “real life” 3 camera production, despite the fact that there will be some technological limitations.

The production must include as many components as possible from the 5G-RECORDS project partner: Encoder / decoder, modem, gateways, MCR, PTP, Inear/mic.

Implements multicamera production with a minimum of 3 5G wireless cameras and 1 wired, all ST2100 infrastructure.

The production is established around TV 2's studio in TIVOLI in Copenhagen, having access to fibre and infrastructure.

TV 2 will provide a full production crew – camera, audio, director and an assigned production-manager.

In addition to this, there will be a 5G S-PN mmWave service for a single PTZ camera.

Production “rundown”

An interview is conducted with 1 host and 2 guest. Marks Smith, IBC, will be the host.

Stedi camera + handheld camera. PTZ camera for overview.

Production - mix between cameras - alternately remote between RAI, BBC and TV 2.

Total duration 6:00 minutes.

There must be 1 overview camera from each production control, that streams live and is collected on a monitor in Tivoli, so you can follow the production here.



5G usecases demo

Copenhagen
June 2022

UC2 block diagram

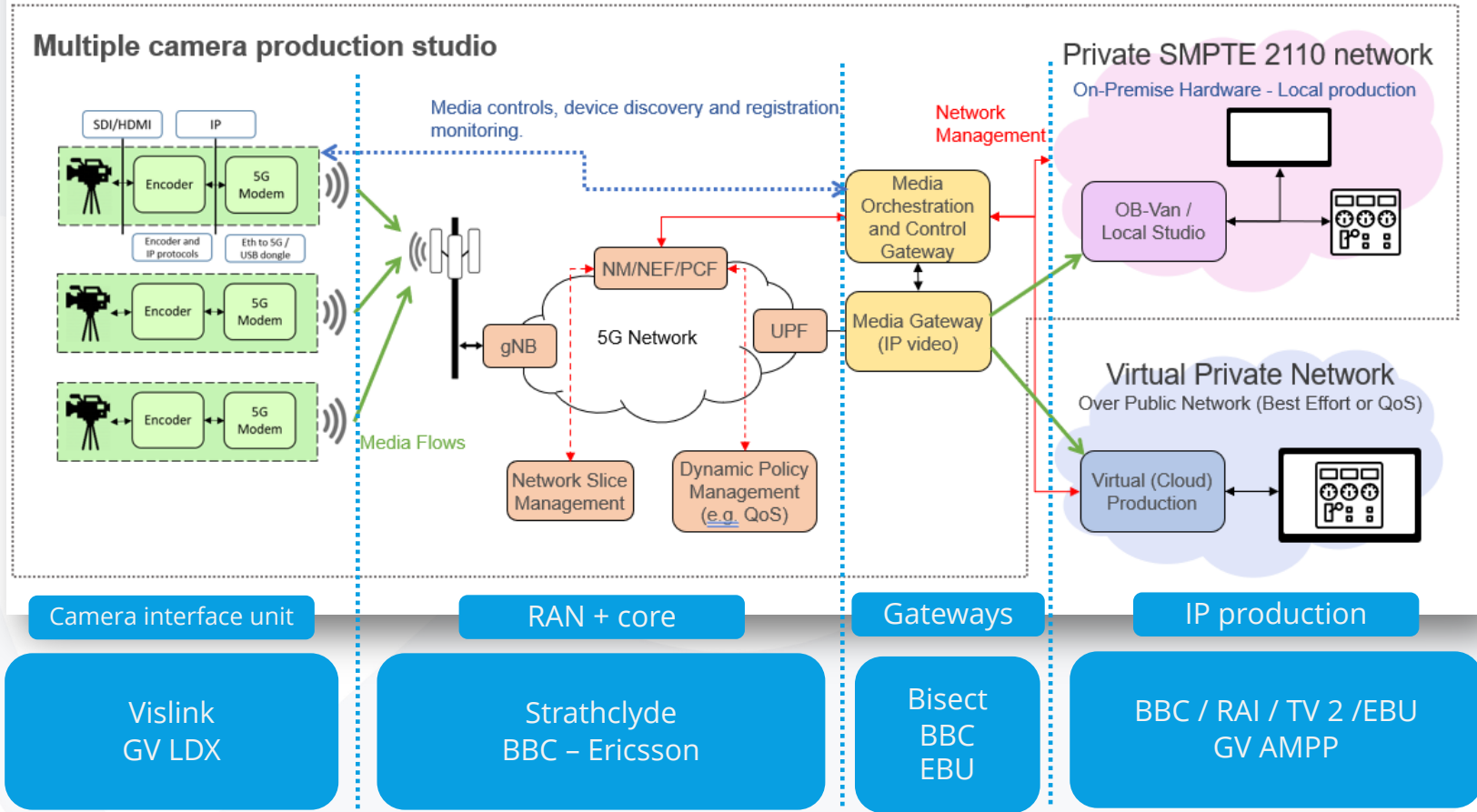

UC2 block diagram

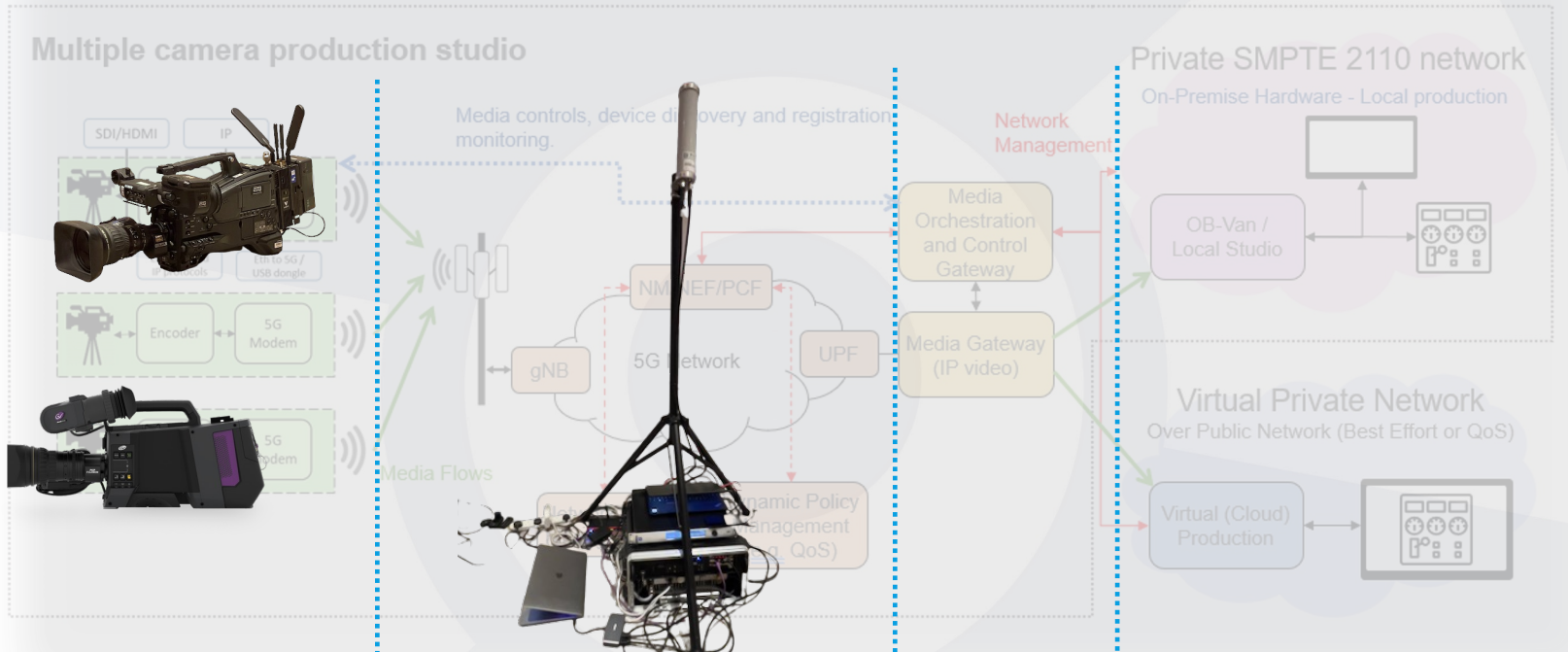

Vislink
GV LDX

Strathclyde
BBC – Ericsson

Bisect
BBC
EBU

BBC / RAI / TV 2 / EBU
GV AMPP

UC2 GV LDX - AMPP

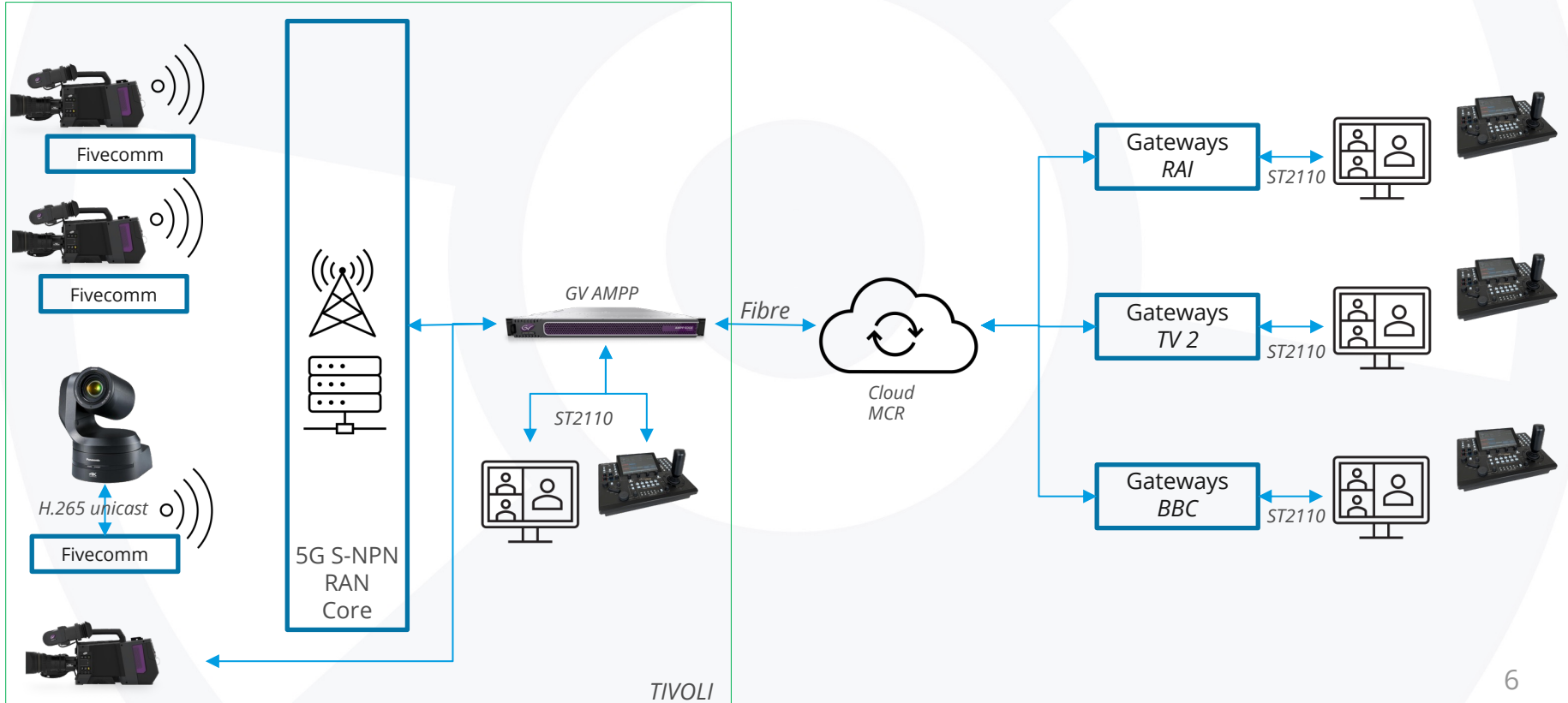

UC2 – TIVOLI Multicam (using 5G RECORDS components)

Portable solutions (Ericsson & Fivecomm based on NVIDIA Jetson)

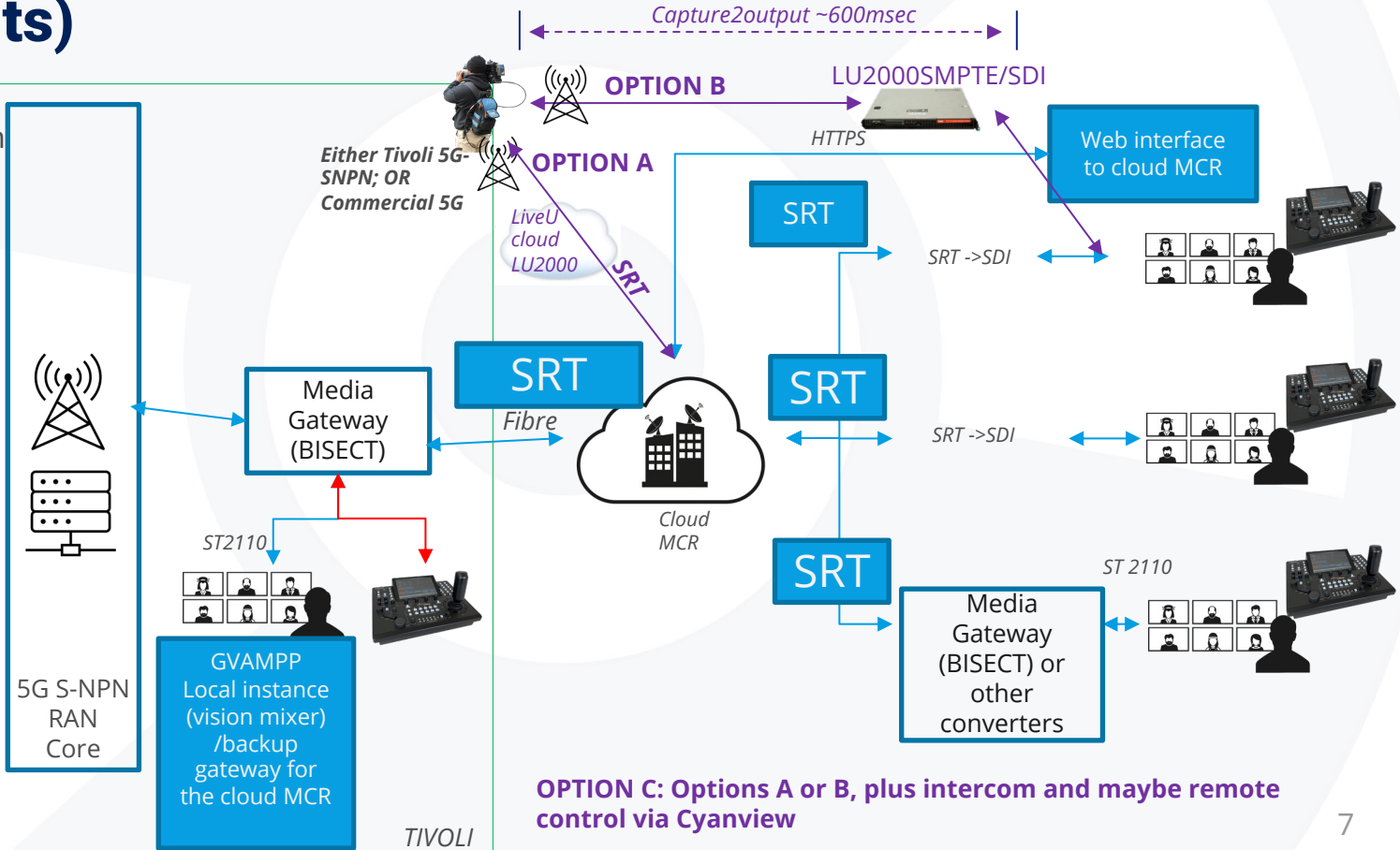

TIVOLI

OPTION C: Options A or B, plus intercom and maybe remote control via Cyanview

UC1+2 – TIVOLI Multicam

Interview option A: local audio production

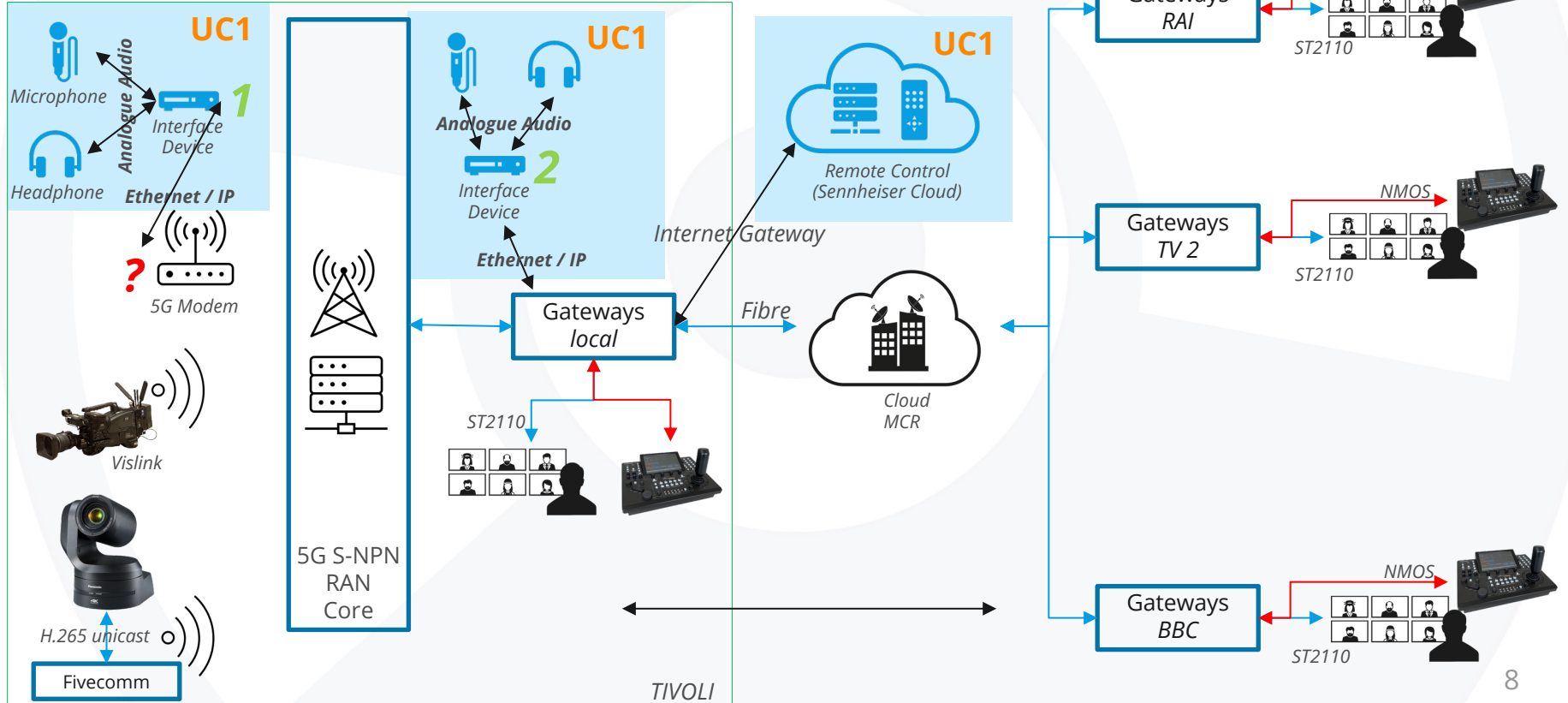

UC1+2 – TIVOLI Multicam

Interview option B: remote audio production

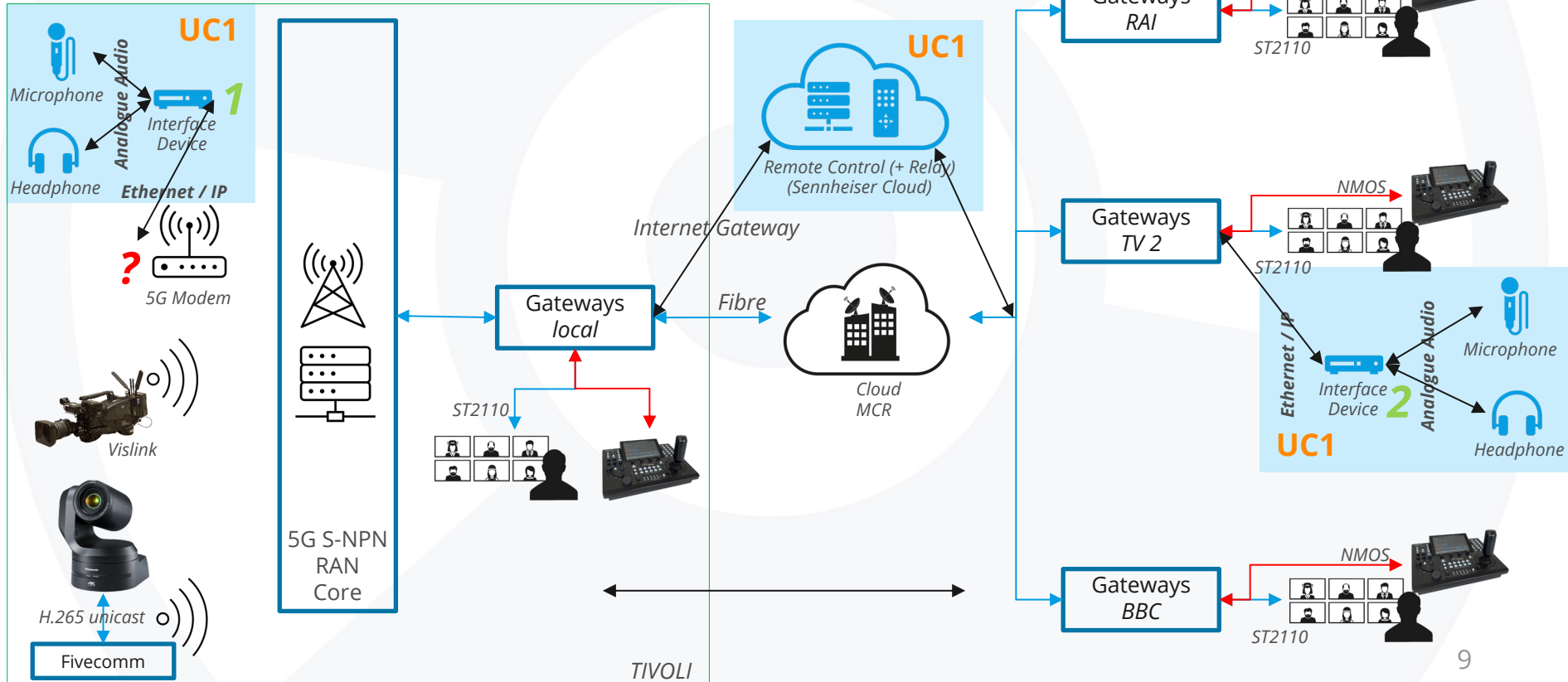

PTZ – mmW

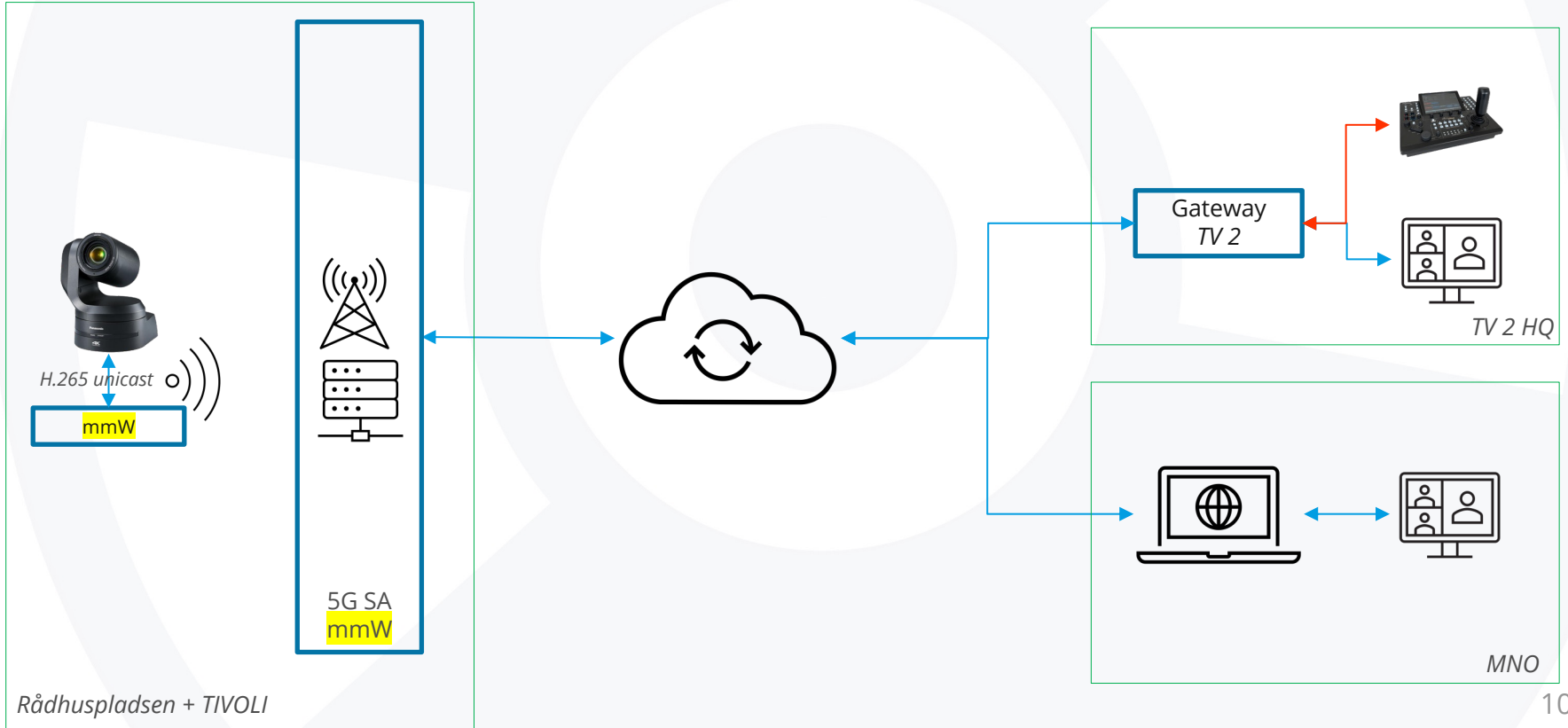

LOCATIONS

Wednesday 29th June – n77 + mmW



TDF
OB compound

DI
5G event venue

Central station

TDF finish line

Town hall

TV 2 Sport
studio

GO
studio

mmW
S-NPN
5G-RECORDS.EU

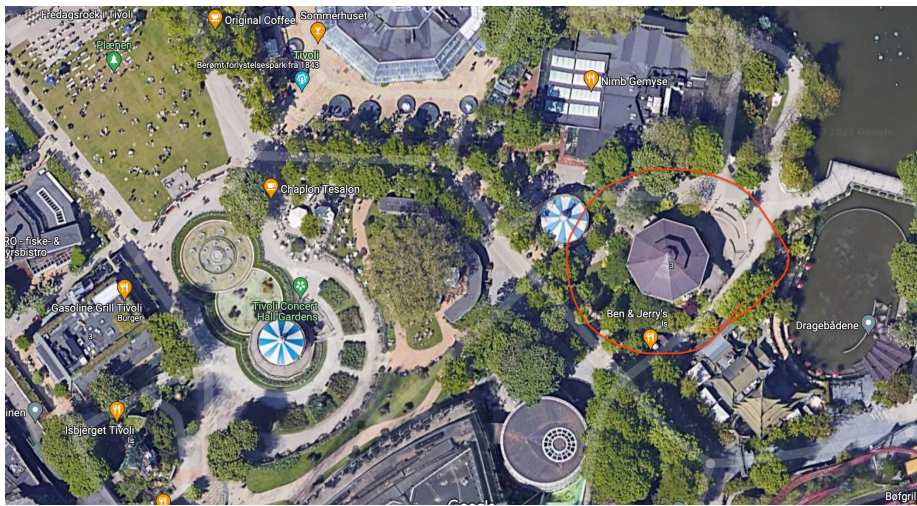

TIVOLI studio

5G WEEK

Copenhagen, Denmark

Monday 27 th June	Tuesday 28 th June	Wednesday 29 th June	Thursday 30 th June	Friday 1 st July	Saturday 2 nd July	Sunday 3 rd July
		5G NPN		5G Production		
		Presentation of the 2022 Tour de France teams at the Tivoli Gardens		Stage 1 Copenhagen > Copenhagen Individual time trial	Stage 2 Roskilde > Nyborg	Stage 3 Vejle > Sønderborg
5G-RECORDS Plenary meeting at TV 2	5G-RECORDS Plenary meeting at TV 2	5G remote production PoC in TIVOLI.				
	5G networking – grab a beer at <i>BlackSwan</i>	5G SEMINAR at DI			<i>Festivo</i> Fælledparken	
				5 mobile TV2DK live team International media in town	+75.000 spectators in Roskilde	

5G PRODUCTION -> 5G BROADCAST

Trail-setup for broadcasting the 5G production output

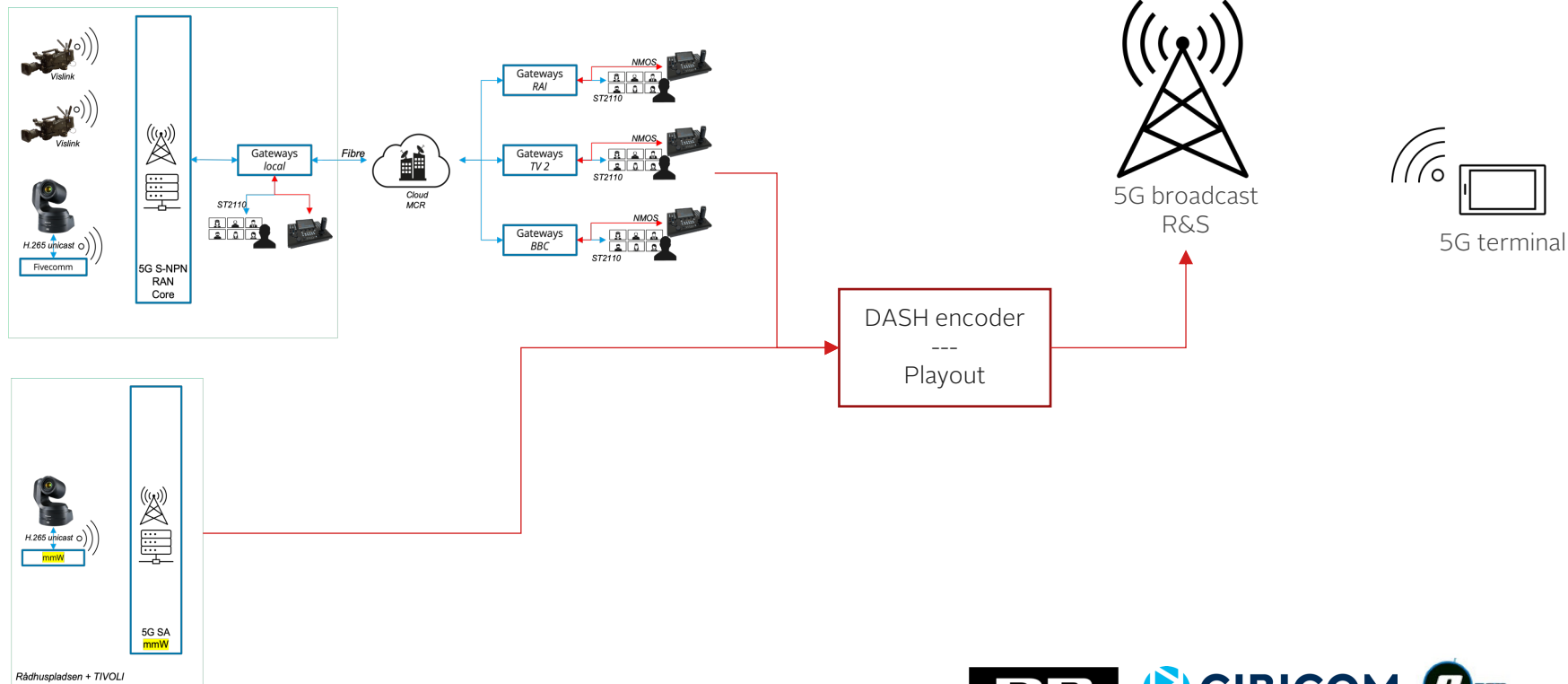

Rådhuspladsen + TIVOLI



LIVE 5G INTERVIEW

5G-RECORDS Trail setup – “GO’ style”

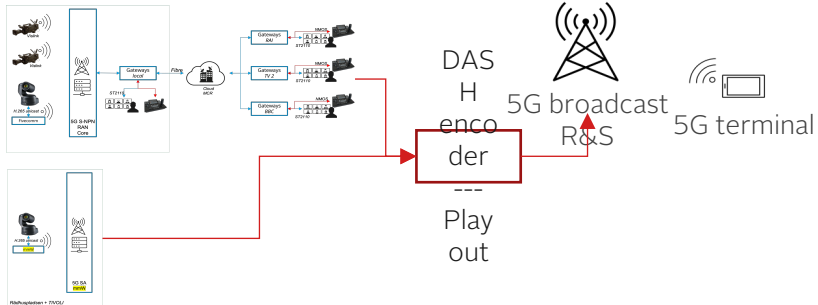

- Live interview in or outside GO’ studio in TIVOLI. Host interviewing
- If time, two versions: 5min in Danish + 5min in English
- Production camera and microphone run on Privat 5G S-NPN.
- 3 camera wireless setup (equal to GO’ typical setup)
- As a (world?) first, this production are broadcasted at the trail 5G broadcast setup
- Rundow:
 - Host and guest
 - Questions and
 - looking at the 5G terminal, showing this program feed (5G Broadcast)
 - End

The logo for SG RECORDS is centered on the page. It features the letters 'SG' in a bold, blue, sans-serif font above the word 'RECORDS' in a similar font. The letter 'O' in 'RECORDS' is replaced by a stylized blue vinyl record with a white center and a black outer ring. The background consists of a large, light gray circular graphic with three white, curved segments that resemble a record's grooves or a stylized 'S' shape.

**SG
RECORDS**

**Morten Brandstrup
MOBR@TV2.DK**